



Chipsmall Limited consists of a professional team with an average of over 10 year of expertise in the distribution of electronic components. Based in Hongkong, we have already established firm and mutual-benefit business relationships with customers from,Europe,America and south Asia,supplying obsolete and hard-to-find components to meet their specific needs.

With the principle of “Quality Parts,Customers Priority,Honest Operation,and Considerate Service”,our business mainly focus on the distribution of electronic components. Line cards we deal with include Microchip,ALPS,ROHM,Xilinx,Pulse,ON,Everlight and Freescale. Main products comprise IC,Modules,Potentiometer,IC Socket,Relay,Connector.Our parts cover such applications as commercial,industrial, and automotives areas.

We are looking forward to setting up business relationship with you and hope to provide you with the best service and solution. Let us make a better world for our industry!



Contact us

Tel: +86-755-8981 8866 Fax: +86-755-8427 6832

Email & Skype: info@chipsmall.com Web: www.chipsmall.com

Address: A1208, Overseas Decoration Building, #122 Zhenhua RD., Futian, Shenzhen, China



4

3

2

1

THIS DRAWING IS UNPUBLISHED. VERTRAULICHE UNVERÖFFENTLICHTE ZEICHNUNG. RELEASED FOR PUBLICATION. FREI FÜR VERÖFFENTLICHUNG. DATED WITH: PASSEND ZU: -

LOC AI - DIST - P LTR -

REVISIONS
ÄNDERUNGEN
DESCRIPTION
BESCHREIBUNG

DATE 25-JAN-01 DWN R.S. APVD G.F.

REV. PER PCN EG00-0288-01

PROJECT NR.: E00-9624 C1

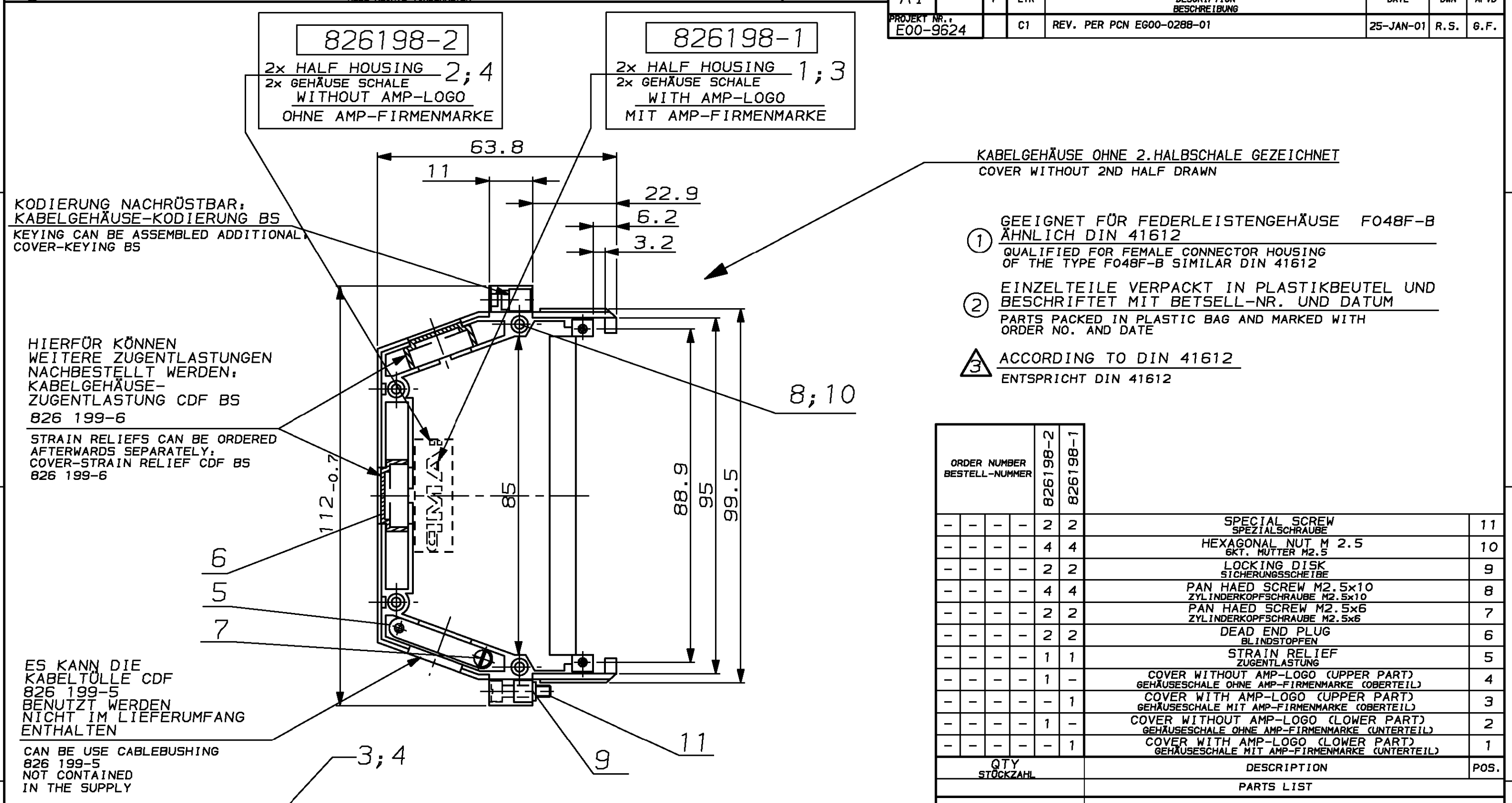

KODIERUNG NACHRÜSTBAR;
KABELGEHÄUSE-KODIERUNG BS
KEYING CAN BE ASSEMBLED ADDITIONAL
COVER-KEYING BS

HIERFÜR KÖNNEN
WEITERE ZUGENTLASTUNGEN
NACHBESTELLT WERDEN;
KABELGEHÄUSE-
ZUGENTLASTUNG CDF BS
826 199-6

STRAIN RELIEFS CAN BE ORDERED
AFTERWARDS SEPARATELY;
COVER-STRAIN RELIEF CDF BS
826 199-6

ES KANN DIE
KABELTÜLLE CDF
826 199-5
BENUTZT WERDEN
NICHT IM LIEFERUMFANG
ENTHALTEN

CAN BE USE CABLEBUSHING
826 199-5
NOT CONTAINED
IN THE SUPPLY

KABELGEHÄUSE OHNE 2. HALBSCHALE GEZEICHNET
COVER WITHOUT 2ND HALF DRAWN

- ① GEEIGNET FÜR FEDERLEISTENGEHÄUSE F048F-B
ÄHNLICH DIN 41612
QUALIFIED FOR FEMALE CONNECTOR HOUSING
OF THE TYPE F048F-B SIMILAR DIN 41612
- ② EINZELTEILE VERPACKT IN PLASTIKBEUTEL UND
BESCHRIFTET MIT BETSELL-NR. UND DATUM
PARTS PACKED IN PLASTIC BAG AND MARKED WITH
ORDER NO. AND DATE
- ③ ACCORDING TO DIN 41612
ENTSPRICHT DIN 41612

ORDER NUMBER BESTELL-NUMMER	826198-2	826198-1		POS.
- - - -	2	2	SPECIAL SCREW SPEZIALSCHRAUBE	11
- - - -	4	4	HEXAGONAL NUT M 2.5 6KT. MÜTTER M2.5	10
- - - -	2	2	LOCKING DISK SICHERUNGSSCHEIBE	9
- - - -	4	4	PAN HAED SCREW M2.5x10 ZYLINDERKOPFSCHRAUBE M2.5x10	8
- - - -	2	2	PAN HAED SCREW M2.5x6 ZYLINDERKOPFSCHRAUBE M2.5x6	7
- - - -	2	2	DEAD END PLUG BLINDSTOPFEN	6
- - - -	1	1	STRAIN RELIEF ZUGENTLASTUNG	5
- - - -	1	-	COVER WITHOUT AMP-LOGO (UPPER PART) GEHÄUSESCHALE OHNE AMP-FIRMENMARKE (OBERTEIL)	4
- - - -	-	1	COVER WITH AMP-LOGO (UPPER PART) GEHÄUSESCHALE MIT AMP-FIRMENMARKE (OBERTEIL)	3
- - - -	1	-	COVER WITHOUT AMP-LOGO (LOWER PART) GEHÄUSESCHALE OHNE AMP-FIRMENMARKE (UNTERTEIL)	2
- - - -	-	1	COVER WITH AMP-LOGO (LOWER PART) GEHÄUSESCHALE MIT AMP-FIRMENMARKE (UNTERTEIL)	1
QTY STÜCKZAHL			DESCRIPTION	
PARTS LIST				

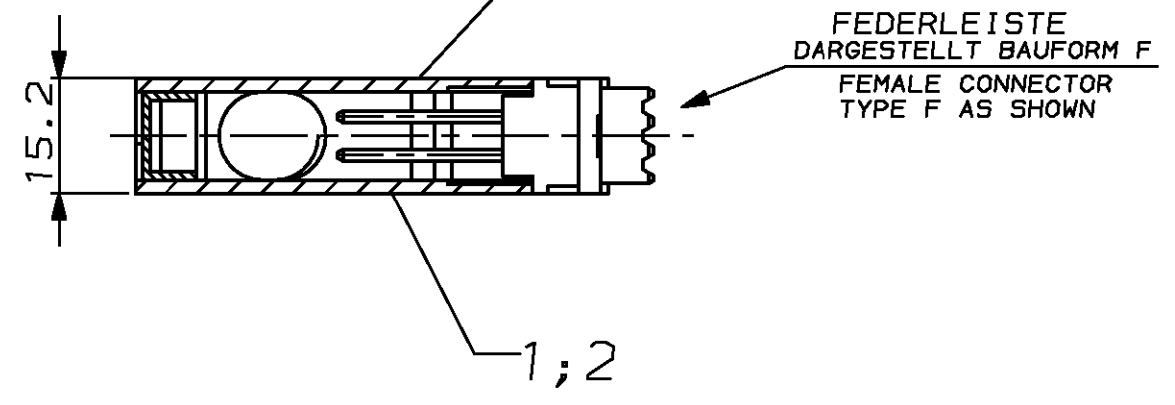

THIS DRAWING IS A CONTROLLED DOCUMENT FOR AMP INCORPORATED. IT IS SUBJECT TO CHANGE AND THE CONTROLLING ENGINEERING ORGANIZATION SHOULD BE CONTACTED FOR THE LATEST REVISION. DIESES ZEICHNUNGSDOKUMENT WIRD DURCH AMP INCORPORATED KONTROLLIERT. ÄNDERUNGEN, DIE DEN TECHNISCHEN FORTSCHRITT DIENEN, SIND VORBEHALTEN. DEN JEMALS LETZTUEBLIGEN ÄNDERUNGSSTAND ERWÄHREN SIE AUF ANFRAGE.

DIMENSIONS, DIMENSIONEN, mm	TOLERANCES UNLESS OTHERWISE SPECIFIED, ALLGEMEINTOLERANZEN
	±0.2
MATERIAL	FINISH/OBERFLÄCHE/FARBE
MAKROLON	GREY ACC. TO RAL7032 GRAU RAL7032

DWN R. Schmidt	16-JAN-01	AMP tyco Electronics AMP GmbH D - 64625 Bensheim
CHK W. BOECK	25-JAN-01	
APVD G. FELDMEIER	25-JAN-01	COVER FOR TYPE F CONNECTOR KABELGEHÄUSE "F"
PRODUCT SPEC PRODUKTSPEZ.		SIZE A3
APPLICATION SPEC VERARBEITUNGSSPEZ.	-	CAGE CODE 00779
WEIGHT GEWICHT	-	DRAWING NO ZEICHNUNGS-NR. 826198
CUSTOMER DRAWING /KUNDENZEICHNUNG		RESTRICTED TO NUR FÜR
MASSTAB 1:1	BLATT 1 VON 1	REV C1