



Chipsmall Limited consists of a professional team with an average of over 10 year of expertise in the distribution of electronic components. Based in Hongkong, we have already established firm and mutual-benefit business relationships with customers from,Europe,America and south Asia,supplying obsolete and hard-to-find components to meet their specific needs.

With the principle of “Quality Parts,Customers Priority,Honest Operation,and Considerate Service”,our business mainly focus on the distribution of electronic components. Line cards we deal with include Microchip,ALPS,ROHM,Xilinx,Pulse,ON,Everlight and Freescale. Main products comprise IC,Modules,Potentiometer,IC Socket,Relay,Connector.Our parts cover such applications as commercial,industrial, and automotives areas.

We are looking forward to setting up business relationship with you and hope to provide you with the best service and solution. Let us make a better world for our industry!



## Contact us

Tel: +86-755-8981 8866 Fax: +86-755-8427 6832

Email & Skype: info@chipsmall.com Web: www.chipsmall.com

Address: A1208, Overseas Decoration Building, #122 Zhenhua RD., Futian, Shenzhen, China



# SPECIFICATION CONTROL DRAWING

82A0811

TITLE	WIRE, RADIATION-CROSSLINKED, MODIFIED FLEXIBLE ETFE-INSULATED, NORMAL WEIGHT, GENERAL PURPOSE, 600 VOLT	Date	11-5-13	Revision	F
-------	---	------	---------	----------	---

This specification sheet forms a part of the latest issue of Raychem Specification 80.

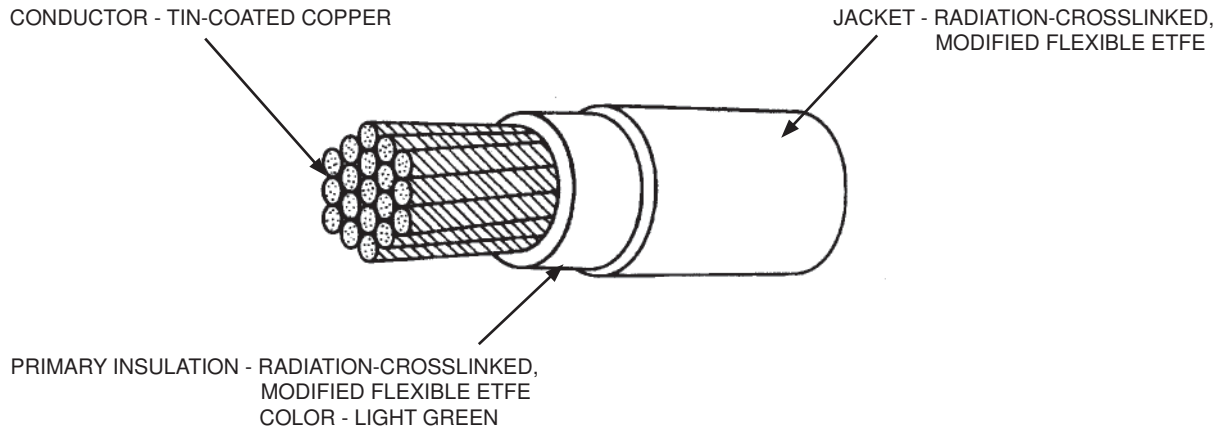

TABLE I. CONSTRUCTION DETAILS

PART NUMBER 1/	WIRE SIZE (AWG)	CONDUCTOR STRANDING (number x AWG)	DIAMETER OF STRANDED CONDUCTOR (inch)		FINISHED WIRE		
			MINIMUM	MAXIMUM	MAXIMUM RESISTANCE AT 20°C (ohms/1000 ft.)	DIAMETER (inch)	MAXIMUM WEIGHT (lbs/1000 ft.)
82A0811-24-*	24	105 x 44	.023	.027	28.2	.044 ± .003	2.5
82A0811-22-*	22	154 x 44	.029	.033	19.2	.054 ± .003	3.7
82A0811-20-*	20	154 x 42	.037	.043	11.7	.064 ± .004	5.2
82A0811-18-*	18	259 x 42	.047	.053	7.14	.076 ± .004	8.0
82A0811-16-*	16	259 x 40	.061	.067	4.53	.092 ± .005	11.9
82A0811-14-*	14	665 x 42	.078	.086	2.96	.116 ± .005	19.3
82A0811-12-*	12	665 x 40	.096	.106	1.89	.137 ± .006	27.9
82A0811-10-*	10	665 x 38	.126	.140	1.12	.187 ± .008	50.0
82A0811-8-*	8	665 x 36	.157	.173	.714	.230 ± .008	77.3
82A0811-6-*	6	1045 x 36	.192	.208	.490	.277 ± .010	118.
82A0811-4-*	4	1665 x 36	.265	.285	.326	.359 ± .010	189.
82A0811-2-*	2	1665 x 34	.325	.345	.204	.433 ± .016	282.
82A0811-1-*	1	2109 x 34	.370	.400	.163	.488 ± .016	348.
82A0811-0-*	0	2660 x 34	.435	.465	.133	.558 ± .016	442.
82A0811-00-*	00	3325 x 34	.485	.515	.102	.612 ± .016	544.
82A0811-000-*	000	4123 x 34	.540	.575	.087	.678 ± .016	668.
82A0811-0000-*	0000	5320 x 34	.615	.655	.066	.771 ± .022	863.

Users should evaluate the suitability of this product for their application. Specifications are subject to change without notice. Tyco Electronics Corporation also reserves the right to make changes in materials or processing, which do not affect compliance with any specification, without notification to Buyer.

1/ COLORS AND COLOR CODE DESIGNATORS SHALL BE IN ACCORDANCE WITH MIL-STD-681. OTHER CODES AND SUFFIXES MAY BE ADDED TO THE PART NUMBER, AS NECESSARY, TO CAPTURE ANY ADDITIONAL REQUIREMENTS IMPOSED BY THE PURCHASE ORDER.

Raychem, TE Connectivity, TE connectivity (logo), and TE (logo) are trademarks.

DIMENSIONS ARE IN INCHES AND, UNLESS OTHERWISE DESIGNATED, ARE NOMINAL.

THIS SPECIFICATION SHEET TAKES PRECEDENCE OVER DOCUMENTS REFERENCED HEREIN. REFERENCED DOCUMENTS SHALL BE OF THE ISSUE IN EFFECT ON DATE OF INVITATION FOR BID.



Raychem Wire & Cable  
501 Oakside Avenue  
Redwood City, CA 94063-3800  
Phone: 1-800-227-8816  
Fax: 1-650-361-6297



# SPECIFICATION CONTROL DRAWING

**82A0811**

Page

2 of 2

Revision

F

TABLE II. PERFORMANCE DETAILS

PART NUMBER 1/	BEND TESTING	
	MANDREL DIAMETER (inch) (± 3%)	WEIGHT (lbs) (± 3%)
	CROSSLINKING PROOF TEST	CROSSLINKING PROOF TEST
82A0811-24-*	.500	.750
82A0811-22-*	.500	1.00
82A0811-20-*	.500	1.50
82A0811-18-*	.750	2.00
82A0811-16-*	1.00	2.00
82A0811-14-*	1.00	3.00
82A0811-12-*	1.50	3.00
82A0811-10-*	2.00	3.00
82A0811-8-*	3.00	4.00
82A0811-6-*	4.00	4.00
82A0811-4-*	5.00	4.00
82A0811-2-*	6.00	6.00
82A0811-1-*	8.00	6.00
82A0811-0-*	8.00	6.00
82A0811-00-*	10.0	8.00
82A0811-000-*	10.0	8.00
82A0811-0000-*	10.0	8.00

## WIRE RATINGS AND ADDITIONAL REQUIREMENTS

**TEMPERATURE RATING: 150°C**

Maximum continuous conductor temperature

**VOLTAGE RATING: 600 volts (rms) at sea level****CONCENTRICITY: 70% (minimum)****CROSSLINKING PROOF TEST: 300 ± 3°C for 7 hours****IDENTIFICATION AND COLOR STRIPING DURABILITY:**

125 cycles (250 strokes) (minimum), 500 g weight

**INSULATION ELONGATION AND TENSILE STRENGTH:**

AWG 24-10: Elongation, 75% (minimum)

Tensile Strength, 3500 lbf/in<sup>2</sup> (minimum)

AWG 8-0000: Elongation, 125% (minimum)

Tensile Strength, 3000 lbf/in<sup>2</sup> (minimum)**INSULATION FLAWS:**

Primary Insulation,

Spark Test, 1.5 kV (rms) at 3 kHz

Impulse Dielectric Test, 6.0 kV (peak)

Finished Wire,

Spark Test, 3.0 kV (rms) at 3 kHz

Impulse Dielectric Test, 8.0 kV (peak)

**INSULATION THICKNESS:**

AWG 24-18: .004 in. (minimum) for primary insulation

.004 in. (minimum) for outer jacket

AWG 16-10: .005 in. (minimum) for primary insulation

.005 in. (minimum) for outer jacket

AWG 8-4: .008 in. (minimum) for primary insulation

.012 in. (minimum) for outer jacket

AWG 2-0000: .010 in. (minimum) for primary insulation

.015 in. (minimum) for outer jacket

**JACKET COLOR: White preferred****SECANT MODULUS (Test per ASTM D 882):**AWG 24-10: 5.0 x 10<sup>4</sup> lbf/in<sup>2</sup> (maximum)AWG 8-0000: 4.0 x 10<sup>4</sup> lbf/in<sup>2</sup> (maximum)

2% strain, 2 inch jaw separation, 0.2 inch/minute

**SHRINKAGE: 150 ± 3°C for 6 hours,**

AWG 24-10: 0.13 in. (maximum) in 12 inches

AWG 8-0000: 0.25 in. (maximum) in 12 inches

**VOLTAGE WITHSTAND (Post Environmental): 2500 volts (rms), 60 Hz****1/ PART NUMBER:**

The "\*" in the part numbers on pages 1 and 2 shall be replaced by a color code designator.

Example: AWG 12, white: 82A0811-12-9

AWG 12, white with a black stripe: 82A0811-12-90

1/ See footer section on page 1