



Chipsmall Limited consists of a professional team with an average of over 10 year of expertise in the distribution of electronic components. Based in Hongkong, we have already established firm and mutual-benefit business relationships with customers from,Europe,America and south Asia,supplying obsolete and hard-to-find components to meet their specific needs.

With the principle of “Quality Parts,Customers Priority,Honest Operation,and Considerate Service”,our business mainly focus on the distribution of electronic components. Line cards we deal with include Microchip,ALPS,ROHM,Xilinx,Pulse,ON,Everlight and Freescale. Main products comprise IC,Modules,Potentiometer,IC Socket,Relay,Connector.Our parts cover such applications as commercial,industrial, and automotives areas.

We are looking forward to setting up business relationship with you and hope to provide you with the best service and solution. Let us make a better world for our industry!



Contact us

Tel: +86-755-8981 8866 Fax: +86-755-8427 6832

Email & Skype: info@chipsmall.com Web: www.chipsmall.com

Address: A1208, Overseas Decoration Building, #122 Zhenhua RD., Futian, Shenzhen, China





21(+1) Channel
High-Density T1/E1/J1
Line Interface Unit
IDT82P2821

Version 3
February 6, 2009

6024 Silver Creek Valley Road, San Jose, California 95138
Telephone: 1-800-345-7015 or 408-284-8200 • TWX: 910-338-2070 • FAX: 408-284-2775
Printed in U.S.A.
© 2009 Integrated Device Technology, Inc.

DISCLAIMER

Integrated Device Technology, Inc. reserves the right to make changes to its products or specifications at any time, without notice, in order to improve design or performance and to supply the best possible product. IDT does not assume any responsibility for use of any circuitry described other than the circuitry embodied in an IDT product. The Company makes no representations that circuitry described herein is free from patent infringement or other rights of third parties which may result from its use. No license is granted by implication or otherwise under any patent, patent rights or other rights, of Integrated Device Technology, Inc.

LIFE SUPPORT POLICY

Integrated Device Technology's products are not authorized for use as critical components in life support devices or systems unless a specific written agreement pertaining to such intended use is executed between the manufacturer and an officer of IDT.

1. Life support devices or systems are devices or systems which (a) are intended for surgical implant into the body or (b) support or sustain life and whose failure to perform, when properly used in accordance with instructions for use provided in the labeling, can be reasonably expected to result in a significant injury to the user.
 2. A critical component is any components of a life support device or system whose failure to perform can be reasonably expected to cause the failure of the life support device or system, or to affect its safety or effectiveness.
-



Table of Contents

TABLE OF CONTENTS	3
LIST OF TABLES	7
LIST OF FIGURES	8
FEATURES	10
APPLICATIONS.....	11
DESCRIPTION.....	11
BLOCK DIAGRAM	12
1 PIN ASSIGNMENT	13
2 PIN DESCRIPTION	18
3 FUNCTIONAL DESCRIPTION	29
3.1 T1 / E1 / J1 MODE SELECTION	29
3.2 RECEIVE PATH	29
3.2.1 Rx Termination	29
3.2.1.1 Receive Differential Mode	29
3.2.1.2 Receive Single Ended Mode	31
3.2.2 Equalizer	32
3.2.2.1 Line Monitor	32
3.2.2.2 Receive Sensitivity	32
3.2.3 Slicer	33
3.2.4 Rx Clock & Data Recovery	33
3.2.5 Decoder	33
3.2.6 Receive System Interface	33
3.2.7 Receiver Power Down	34
3.3 TRANSMIT PATH	34
3.3.1 Transmit System Interface	34
3.3.2 Tx Clock Recovery	35
3.3.3 Encoder	35
3.3.4 Waveform Shaper	35
3.3.4.1 Preset Waveform Template	35
3.3.4.2 User-Programmable Arbitrary Waveform	37
3.3.5 Line Driver	39
3.3.5.1 Transmit Over Current Protection	39
3.3.6 Tx Termination	39
3.3.6.1 Transmit Differential Mode	39
3.3.6.2 Transmit Single Ended Mode	40
3.3.7 Transmitter Power Down	41
3.3.8 Output High-Z on TTIP and TRING	41
3.4 JITTER ATTENUATOR (RJA & TJA)	42

3.5	DIAGNOSTIC FACILITIES	43
3.5.1	Bipolar Violation (BPV) / Code Violation (CV) Detection and BPV Insertion	43
3.5.1.1	Bipolar Violation (BPV) / Code Violation (CV) Detection	43
3.5.1.2	Bipolar Violation (BPV) Insertion	43
3.5.2	Excessive Zeroes (EXZ) Detection	43
3.5.3	Loss of Signal (LOS) Detection	44
3.5.3.1	Line LOS (LLOS)	44
3.5.3.2	System LOS (SLOS)	45
3.5.3.3	Transmit LOS (TLOS)	46
3.5.4	Alarm Indication Signal (AIS) Detection and Generation	47
3.5.4.1	Alarm Indication Signal (AIS) Detection	47
3.5.4.2	(Alarm Indication Signal) AIS Generation	47
3.5.5	PRBS, QRSS, ARB and IB Pattern Generation and Detection	48
3.5.5.1	Pattern Generation	48
3.5.5.2	Pattern Detection	49
3.5.6	Error Counter	50
3.5.6.1	Automatic Error Counter Updating	50
3.5.6.2	Manual Error Counter Updating	51
3.5.7	Receive /Transmit Multiplex Function (RMF / TMF) Indication	52
3.5.7.1	RMFn Indication	52
3.5.7.2	TMFn Indication	53
3.5.8	Loopback	54
3.5.8.1	Analog Loopback	54
3.5.8.2	Remote Loopback	55
3.5.8.3	Digital Loopback	56
3.5.8.4	Dual Loopback	57
3.5.9	Channel 0 Monitoring	59
3.5.9.1	G.772 Monitoring	59
3.5.9.2	Jitter Measurement (JM)	60
3.6	CLOCK INPUTS AND OUTPUTS	61
3.6.1	Free Running Clock Outputs on CLK1/CLKE1	61
3.6.2	Clock Outputs on REFA/REFB	62
3.6.2.1	REFA/REFB in Clock Recovery Mode	62
3.6.2.2	Frequency Synthesizer for REFA Clock Output	62
3.6.2.3	Free Run Mode for REFA Clock Output	62
3.6.2.4	REFA/REFB Driven by External CLKA/CLKB Input	62
3.6.2.5	REFA and REFB in Loss of Signal (LOS) or Loss of Clock Condition	62
3.6.3	MCLK, Master Clock Input	66
3.6.4	XCLK, Internal Reference Clock Input	66
3.7	INTERRUPT SUMMARY	67
4	MISCELLANEOUS	69
4.1	RESET	69
4.1.1	Power-On Reset	70
4.1.2	Hardware Reset	70
4.1.3	Global Software Reset	70

4.1.4	Per-Channel Software Reset	70
4.2	MICROPROCESSOR INTERFACE	70
4.3	POWER UP	71
4.4	HITLESS PROTECTION SWITCHING (HPS) SUMMARY	71
5	PROGRAMMING INFORMATION	74
5.1	REGISTER MAP	74
5.1.1	Global Register	74
5.1.2	Per-Channel Register	75
5.2	REGISTER DESCRIPTION	78
5.2.1	Global Register	78
5.2.2	Per-Channel Register	87
6	JTAG	118
6.1	JTAG INSTRUCTION REGISTER (IR)	118
6.2	JTAG DATA REGISTER	118
6.2.1	Device Identification Register (IDR)	118
6.2.2	Bypass Register (BYP)	118
6.2.3	Boundary Scan Register (BSR)	118
6.3	TEST ACCESS PORT (TAP) CONTROLLER	118
7	THERMAL MANAGEMENT	120
7.1	JUNCTION TEMPERATURE	120
7.2	EXAMPLE OF JUNCTION TEMPERATURE CALCULATION	120
7.3	HEATSINK EVALUATION	120
8	PHYSICAL AND ELECTRICAL SPECIFICATIONS	121
8.1	ABSOLUTE MAXIMUM RATINGS	121
8.2	RECOMMENDED OPERATING CONDITIONS	122
8.3	DEVICE POWER CONSUMPTION AND DISSIPATION (TYPICAL) 1	123
8.4	DEVICE POWER CONSUMPTION AND DISSIPATION (MAXIMUM) 1	124
8.5	D.C. CHARACTERISTICS	125
8.6	E1 RECEIVER ELECTRICAL CHARACTERISTICS	126
8.7	T1/J1 RECEIVER ELECTRICAL CHARACTERISTICS	127
8.8	E1 TRANSMITTER ELECTRICAL CHARACTERISTICS	128
8.9	T1/J1 TRANSMITTER ELECTRICAL CHARACTERISTICS	129
8.10	TRANSMITTER AND RECEIVER TIMING CHARACTERISTICS	130
8.11	CLKE1 TIMING CHARACTERISTICS	132
8.12	JITTER ATTENUATION CHARACTERISTICS	133
8.13	MICROPROCESSOR INTERFACE TIMING	136
8.13.1	Serial Microprocessor Interface	136
8.13.2	Parallel Motorola Non-Multiplexed Microprocessor Interface	138
8.13.2.1	Read Cycle Specification	138
8.13.2.2	Write Cycle Specification	139
8.13.3	Parallel Intel Non-Multiplexed Microprocessor Interface	140
8.13.3.1	Read Cycle Specification	140
8.13.3.2	Write Cycle Specification	141

8.13.4 Parallel Motorola Multiplexed Microprocessor Interface	142
8.13.4.1 Read Cycle Specification	142
8.13.4.2 Write Cycle Specification	143
8.13.5 Parallel Intel Multiplexed Microprocessor Interface	144
8.13.5.1 Read Cycle Specification	144
8.13.5.2 Write Cycle Specification	145
8.14 JTAG TIMING CHARACTERISTICS	146
GLOSSARY	147
INDEX	149
ORDERING INFORMATION	151



List of Tables

Table-1	Operation Mode Selection	29
Table-2	Impedance Matching Value in Receive Differential Mode	30
Table-3	Multiplex Pin Used in Receive System Interface	33
Table-4	Multiplex Pin Used in Transmit System Interface	35
Table-5	PULS[3:0] Setting in T1/J1 Mode	36
Table-6	PULS[3:0] Setting in E1 Mode	36
Table-7	Transmit Waveform Value for T1 0 ~ 133 ft	38
Table-8	Transmit Waveform Value for T1 133 ~ 266 ft	38
Table-9	Transmit Waveform Value for T1 266 ~ 399 ft	38
Table-10	Transmit Waveform Value for T1 399 ~ 533 ft	38
Table-11	Transmit Waveform Value for T1 533 ~ 655 ft	38
Table-12	Transmit Waveform Value for E1 75 ohm	38
Table-13	Transmit Waveform Value for E1 120 ohm	38
Table-14	Transmit Waveform Value for J1 0 ~ 655 ft	38
Table-15	Impedance Matching Value in Transmit Differential Mode	39
Table-16	EXZ Definition	43
Table-17	LLOS Criteria	44
Table-18	SLOS Criteria	45
Table-19	TLOS Detection Between Two Channels	46
Table-20	AIS Criteria	47
Table-21	RMFn Indication	52
Table-22	TMFn Indication	53
Table-23	Clock Output on CLK1	61
Table-24	Clock Output on CLKE1	61
Table-25	Interrupt Summary	67
Table-26	After Reset Effect Summary	69
Table-27	Microprocessor Interface	70



List of Figures

Figure-1	Functional Block Diagram	12
Figure-2	640-Pin TEPBGA (Top View) - Outline	13
Figure-3	640-Pin TEPBGA (Top View) - Top Left	14
Figure-4	640-Pin TEPBGA (Top View) - Top Right	15
Figure-5	640-Pin TEPBGA (Top View) - Bottom Left	16
Figure-6	640-Pin TEPBGA (Top View) - Bottom Right	17
Figure-7	Switch between Impedance Matching Modes	29
Figure-8	Receive Differential Line Interface with Twisted Pair Cable (with transformer)	30
Figure-9	Receive Differential Line Interface with Coaxial Cable (with transformer)	30
Figure-10	Receive Differential Line Interface with Twisted Pair Cable (transformer-less, non standard compliant)	31
Figure-11	Receive Single Ended Line Interface with Coaxial Cable (with transformer)	31
Figure-12	Receive Single Ended Line Interface with Coaxial Cable (transformer-less, non standard compliant)	31
Figure-13	Receive Path Monitoring	32
Figure-14	Transmit Path Monitoring	32
Figure-15	DSX-1 Waveform Template	35
Figure-16	T1 Waveform Template Measurement Circuit	35
Figure-17	E1 Waveform Template	36
Figure-18	E1 Waveform Template Measurement Circuit	36
Figure-19	Transmit Differential Line Interface with Twisted Pair Cable (with Transformer)	40
Figure-20	Transmit Differential Line Interface with Coaxial Cable (with transformer)	40
Figure-21	Transmit Differential Line Interface with Twisted Pair Cable (transformer-less, non standard compliant)	40
Figure-22	Transmit Single Ended Line Interface with Coaxial Cable (with transformer)	40
Figure-23	Jitter Attenuator	42
Figure-24	LLOS Indication on Pins	44
Figure-25	TLOS Detection Between Two Channels	46
Figure-26	Pattern Generation (1)	48
Figure-27	Pattern Generation (2)	48
Figure-28	PRBS / ARB Detection	49
Figure-29	IB Detection	50
Figure-30	Automatic Error Counter Updating	51
Figure-31	Manual Error Counter Updating	51
Figure-32	Priority Of Diagnostic Facilities During Analog Loopback	54
Figure-33	Priority Of Diagnostic Facilities During Manual Remote Loopback	55
Figure-34	Priority Of Diagnostic Facilities During Digital Loopback	56
Figure-35	Priority Of Diagnostic Facilities During Manual Remote Loopback + Manual Digital Loopback	58
Figure-36	Priority Of Diagnostic Facilities During Manual Remote Loopback + Automatic Digital Loopback	58
Figure-37	G.772 Monitoring	59
Figure-38	Automatic JM Updating	60
Figure-39	Manual JM Updating	60
Figure-40	REFA Output Options in Normal Operation	63
Figure-41	REFB Output Options in Normal Operation	64
Figure-42	REFA Output in LLOS Condition (When RCLKn Is Selected)	64
Figure-43	REFA Output in No CLKA Condition (When CLKA Is Selected)	65
Figure-44	Interrupt Service Process	68
Figure-45	Reset	69
Figure-46	1+1 HPS Scheme, Differential Interface (Shared Common Transformer)	71
Figure-47	1:1 HPS Scheme, Differential Interface (Individual Transformer)	72
Figure-48	1+1 HPS Scheme, E1 75 ohm Single-Ended Interface (Shared Common Transformer)	73

Figure-49 JTAG Architecture	118
Figure-50 JTAG State Diagram	119
Figure-51 Transmit Clock Timing Diagram	131
Figure-52 Receive Clock Timing Diagram	131
Figure-53 CLKE1 Clock Timing Diagram	132
Figure-54 E1 Jitter Tolerance Performance	134
Figure-55 T1/J1 Jitter Tolerance Performance	134
Figure-56 E1 Jitter Transfer Performance	135
Figure-57 T1/J1 Jitter Transfer Performance	135
Figure-58 Read Operation in Serial Microprocessor Interface	136
Figure-59 Write Operation in Serial Microprocessor Interface	136
Figure-60 Timing Diagram	137
Figure-61 Parallel Motorola Non-Multiplexed Microprocessor Interface Read Cycle	138
Figure-62 Parallel Motorola Non-Multiplexed Microprocessor Interface Write Cycle	139
Figure-63 Parallel Intel Non-Multiplexed Microprocessor Interface Read Cycle	140
Figure-64 Parallel Intel Non-Multiplexed Microprocessor Interface Write Cycle	141
Figure-65 Parallel Motorola Multiplexed Microprocessor Interface Read Cycle	142
Figure-66 Parallel Motorola Multiplexed Microprocessor Interface Write Cycle	143
Figure-67 Parallel Intel Multiplexed Microprocessor Interface Read Cycle	144
Figure-68 Parallel Intel Multiplexed Microprocessor Interface Write Cycle	145
Figure-69 JTAG Timing	146



21(+1) Channel High-Density T1/E1/J1 Line Interface Unit

IDT82P2821

FEATURES

- ◆ **Integrates 21+1 channels T1/E1/J1 short haul line interface units for 100 Ω T1, 120 Ω E1, 110 Ω J1 twisted pair cable and 75 Ω E1 coaxial cable applications**
- ◆ **Per-channel configurable Line Interface options**
 - Supports various line interface options
 - *Differential and Single Ended line interfaces*
 - *true Single Ended termination on primary and secondary side of transformer for E1 75 Ω coaxial cable applications*
 - *transformer-less for Differential interfaces*
 - Fully integrated and software selectable receive and transmit termination
 - *Option 1: Fully Internal Impedance Matching with integrated receive termination resistor*
 - *Option 2: Partially Internal Impedance Matching with common external resistor for improved device power dissipation*
 - *Option 3: External impedance Matching termination*
 - Supports global configuration and per-channel configuration to T1, E1 or J1 mode
- ◆ **Per-channel programmable features**
 - Provides T1/E1/J1 short haul waveform templates and user-programmable arbitrary waveform templates
 - Provides two JAs (Jitter Attenuator) for each channel of receiver and transmitter
 - Supports AMI/B8ZS (for T1/J1) and AMI/HDB3 (for E1) encoding and decoding
- ◆ **Per-channel System Interface options**
 - Supports Single Rail, Dual Rail with clock or without clock and sliced system interface
 - Integrated Clock Recovery for the transmit interface to recover transmit clock from system transmit data
- ◆ **Per-channel system and diagnostic functions**
 - Provides transmit driver over-current detection and protection with optional automatic high impedance of transmit interface
 - Detects and generates PRBS (Pseudo Random Bit Sequence), ARB (Arbitrary Pattern) and IB (Inband Loopback) in either receive or transmit direction
 - Provides defect and alarm detection in both receive and transmit directions.
 - *Defects include BPV (Bipolar Violation) /CV (Code Violation) and EXZ (Excessive Zeroes)*
 - *Alarms include LLOS (Line LOS), SLOS (System LOS), TLOS (Transmit LOS) and AIS (Alarm Indication Signal)*
 - Programmable LLOS detection /clear levels. Compliant with ITU and ANSI specifications
 - Various pattern, defect and alarm reporting options
 - *Serial hardware LLOS reporting (LLOS, LLOS0) for all 22 channels*
 - *Configurable per-channel hardware reporting with RMF/TMF (Receive /Transmit Multiplex Function)*
 - *Register access to individual registers or 16-bit error counters*
- Supports Analog Loopback, Digital Loopback and Remote Loopback
- Supports T1.102 line monitor
- ◆ **Channel 0 monitoring options**
 - Channel 0 can be configured as monitoring channel or regular channel to increase capacity
 - Supports all internal G.772 Monitoring for Non-Intrusive Monitoring of any of the 21 channels of receiver or transmitter
 - Jitter Measurement per ITU O.171
- ◆ **Hitless Protection Switching (HPS) without external Relays**
 - Supports 1+1 and 1:1 hitless protection switching
 - Asynchronous hardware control (OE, RIM) for fast global high impedance of receiver and transmitter (hot switching between working and backup board)
 - High impedance transmitter and receiver while powered down
 - Per-channel register control for high impedance, independent for receiver and transmitter
- ◆ **Clock Inputs and Outputs**
 - Flexible master clock (N x 1.544 MHz or N x 2.048 MHz) ($1 \leq N \leq 8$, N is an integer number)
 - Two selectable reference clock outputs
 - *from the recovered clock of any of the 22 channels*
 - *from external clock input*
 - *from device master clock*
 - Integrated clock synthesizer can multiply or divide the reference clock to a wide range of frequencies: 8 KHz, 64 KHz, 2.048 MHz, 4.096 MHz, 8.192 MHz, 19.44 MHz and 32.768 MHz
 - Cascading is provided to select a single reference clock from multiple devices without the need for any external logic
- ◆ **Microprocessor Interface**
 - Supports Serial microprocessor interface and Parallel Intel / Motorola Non-Multiplexed /Multiplexed microprocessor interface
- ◆ **Other Key Features**
 - IEEE1149.1 JTAG boundary scan
 - Two general purpose I/O pins
 - 3.3 V I/O with 5 V tolerant inputs
 - 3.3 V and 1.8 V power supply
 - Package: 640-pin TEPBGA (31 mm X 31 mm)
- ◆ **Applicable Standards**
 - AT&T Pub 62411 Accunet T1.5 Service
 - ANSI T1.102, T1.403 and T1.231
 - Bellcore TR-TSY-000009, GR-253-CORE and GR-499-CORE
 - ETSI CTR12/13
 - ETS 300166 and ETS 300 233
 - G.703, G.735, G.736, G.742, G.772, G.775, G.783 and G.823
 - O.161
 - ITU I.431 and ITU O.171

APPLICATIONS

- ◆ SDH/SONET multiplexers
- ◆ Central office or PBX (Private Branch Exchange)
- ◆ Digital access cross connects
- ◆ Remote wireless modules
- ◆ Microwave transmission systems

DESCRIPTION

The IDT82P2821 is a 21+1 channels high-density T1/E1/J1 short haul Line Interface Unit. Each channel of the IDT82P2821 can be independently configured. The configuration is performed through a Serial or Parallel Intel/Motorola Non-Multiplexed /Multiplexed microprocessor interface.

In the receive path, through a Single Ended or Differential line interface, the received signal is processed by an adaptive Equalizer and then sent to a Slicer. Clock and data are recovered from the digital pulses output from the Slicer. After passing through an enabled or disabled Receive Jitter Attenuator, the recovered data is decoded using B8ZS/AMI/HDB3 line code rule in Single Rail NRZ Format mode and output to the system, or output to the system without decoding in Dual Rail NRZ Format mode and Dual Rail RZ Format mode.

In the transmit path, the data to be transmitted is input on TDn in Single Rail NRZ Format mode or TDPn/TDNn in Dual Rail NRZ Format mode and Dual Rail RZ Format mode, and is sampled by a transmit reference clock. The clock can be supplied externally from TCLKn or recovered from the input transmit data by an internal Clock Recovery. A selectable JA in Tx path is used to de-jitter gapped clocks. To meet T1/E1/J1 waveform standards, five preset T1 templates and two E1 templates, as well as an arbitrary waveform generator are provided. The data through the Waveform Shaper, the Line Driver and the Tx Transmitter is output on TTIPn and TRINGn.

Alarms (including LOS, AIS) and defects (including BPV, EXZ) are detected in both receive line side and transmit system side. AIS alarm, PRBS, ARB and IB patterns can be generated /detected in receive /transmit direction for testing purpose. Analog Loopback, Digital Loopback and Remote Loopback are all integrated for diagnostics.

Channel 0 is a special channel. Besides normal operation as the other 21 channels, channel 0 also supports G.772 Monitoring and Jitter Measurement per ITU O.171.

A line monitor function per T1.102 is available to provide a Non-Intrusive Monitoring of channels of other devices.

JTAG per IEEE 1149.1 is also supported by the IDT82P2821.

BLOCK DIAGRAM

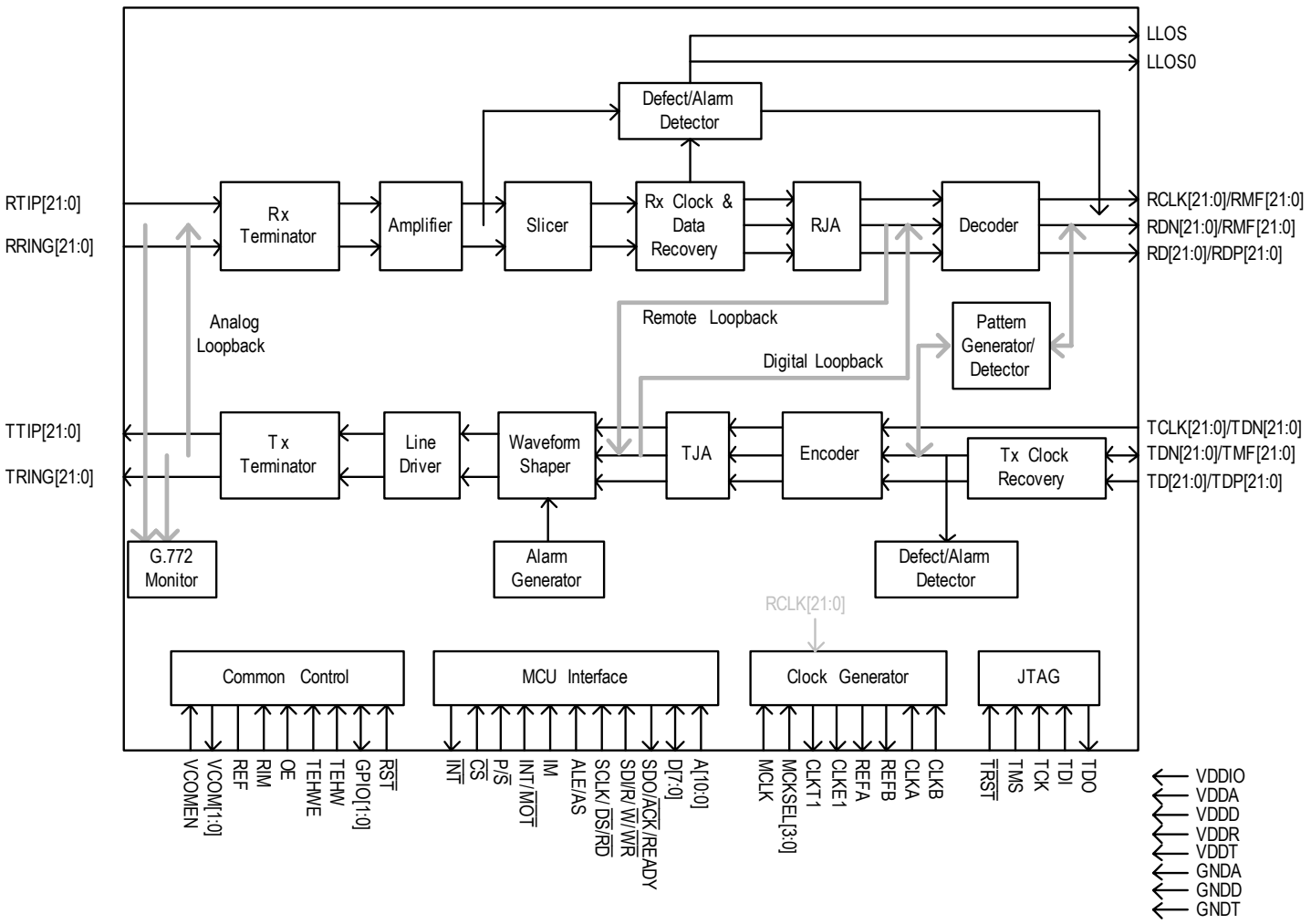

Figure-1 Functional Block Diagram

1 PIN ASSIGNMENT

Figure-2 shows the outline of the pin assignment. For a clearer description, four segments are divided in this figure and the details of each are shown from Figure-3 to Figure-6.

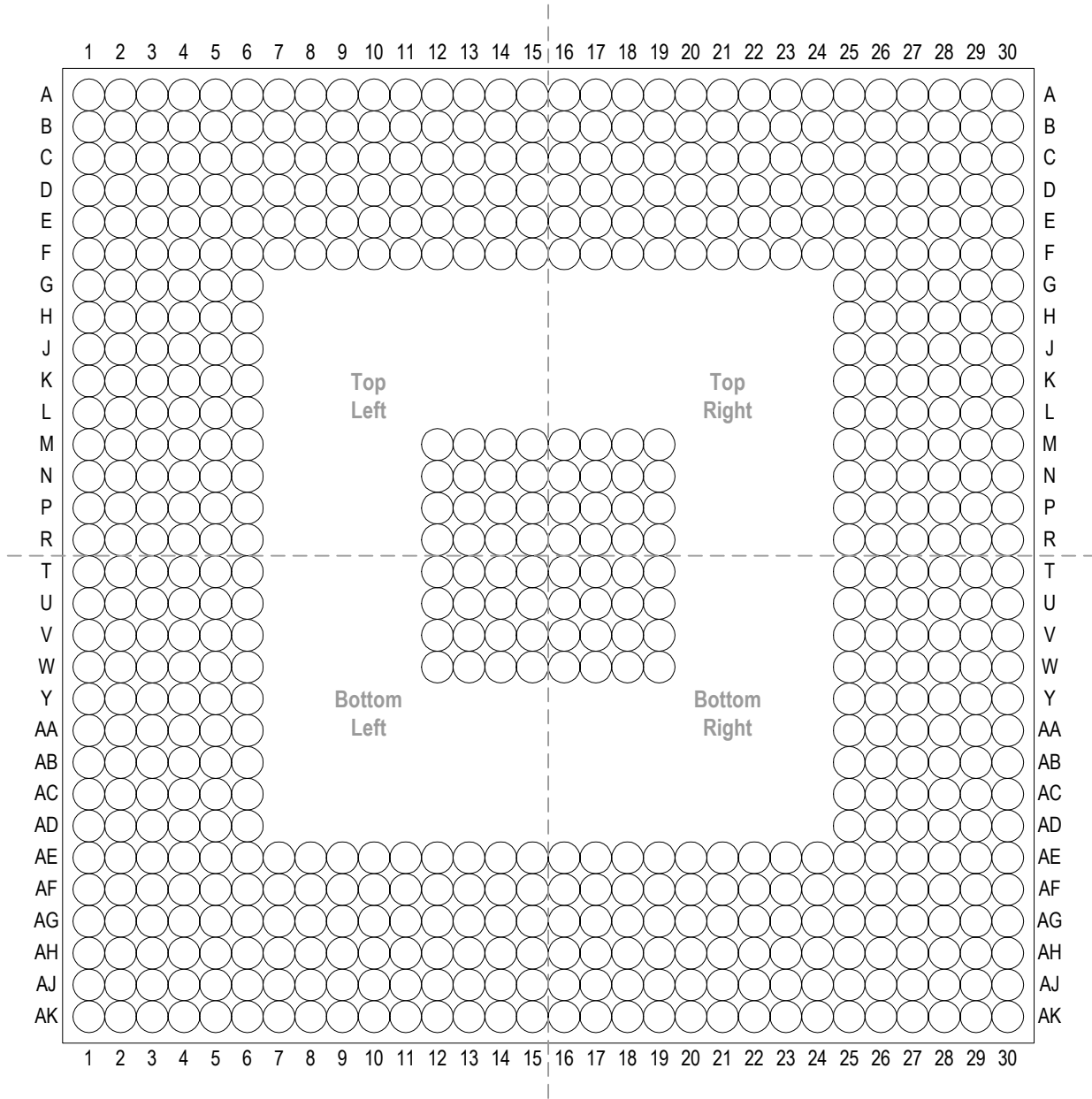

Figure-2 640-Pin TEPBGA (Top View) - Outline

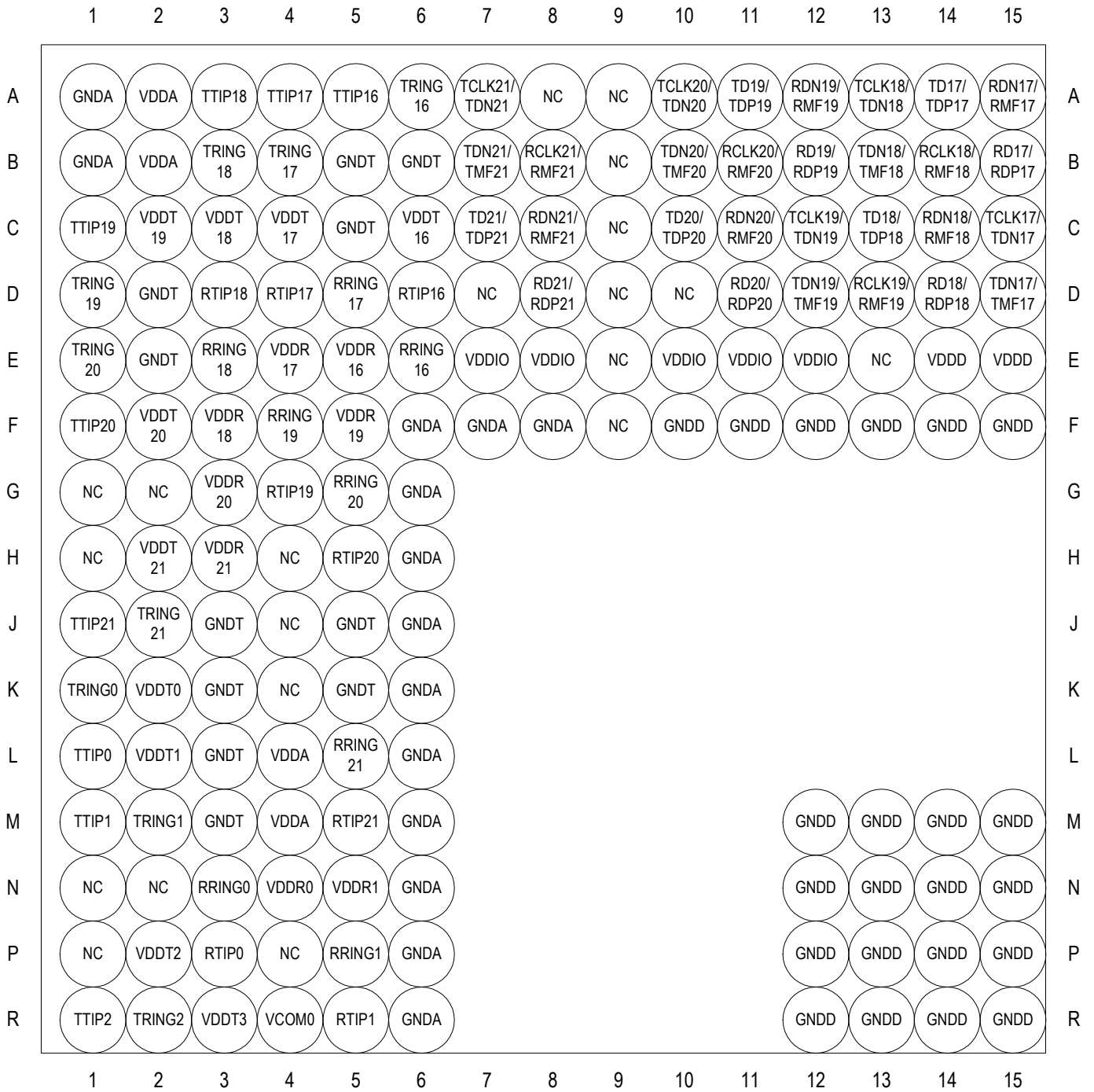

Figure-3 640-Pin TEPBGA (Top View) - Top Left

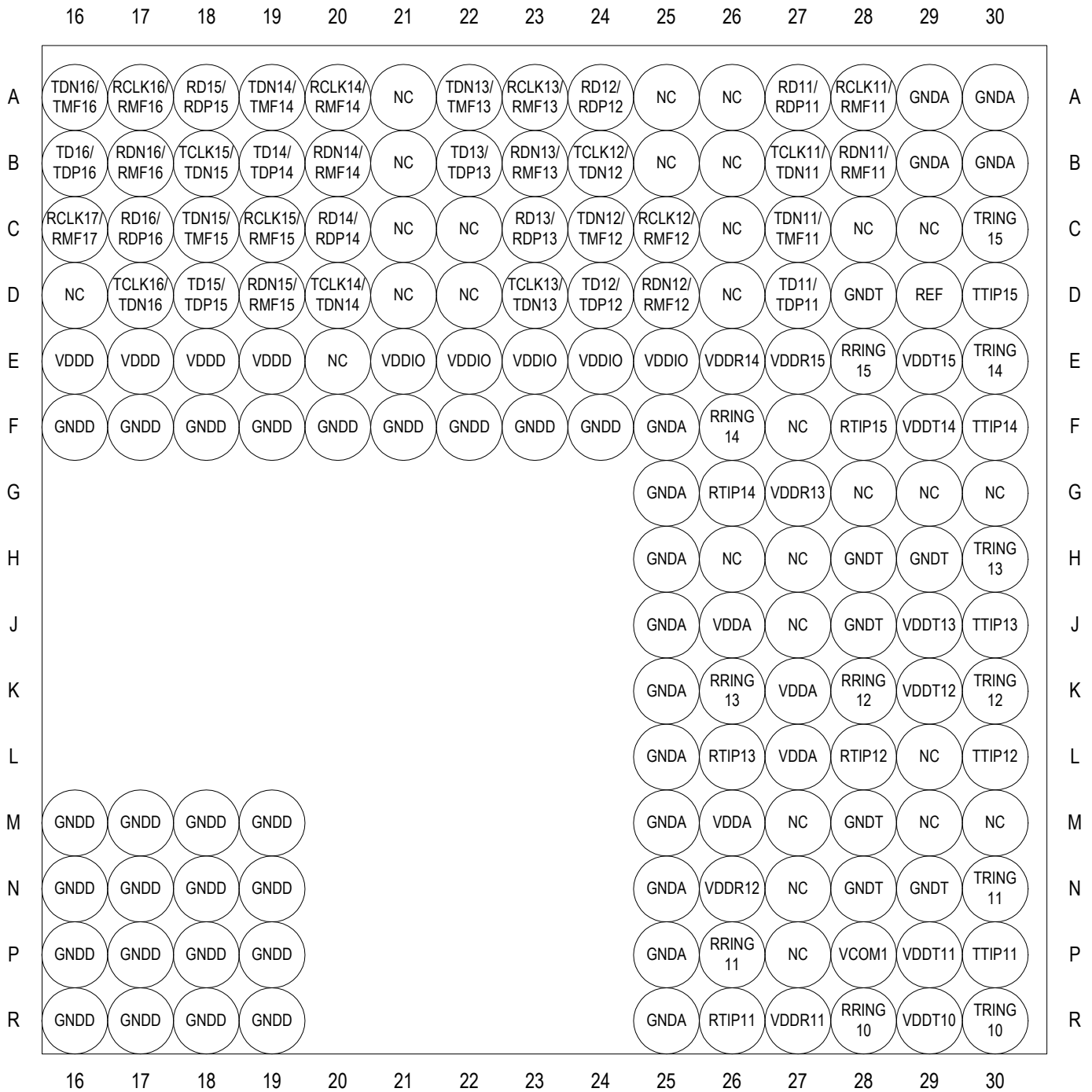

Figure-4 640-Pin TEPBGA (Top View) - Top Right

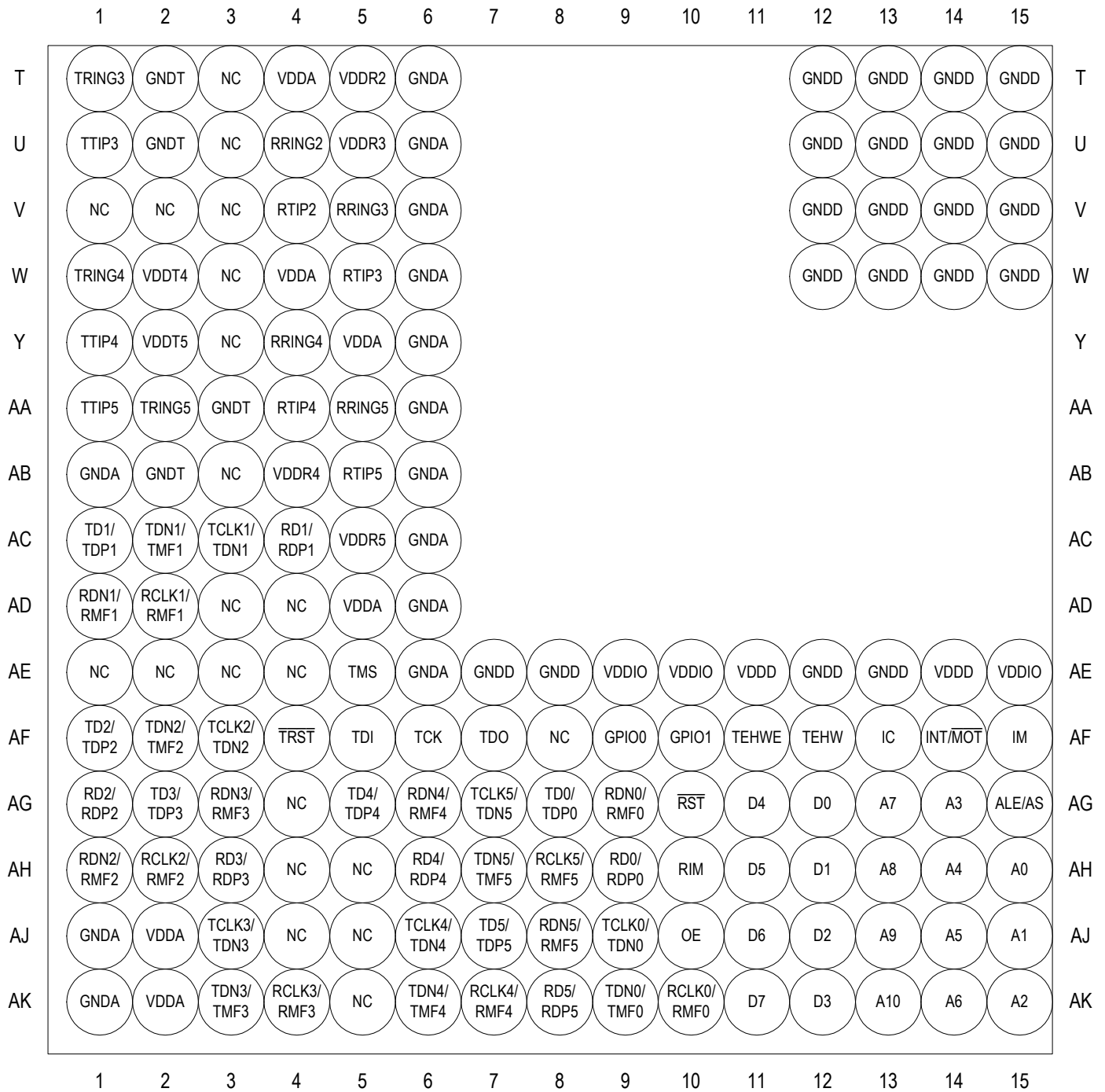

Figure-5 640-Pin TEPBGA (Top View) - Bottom Left

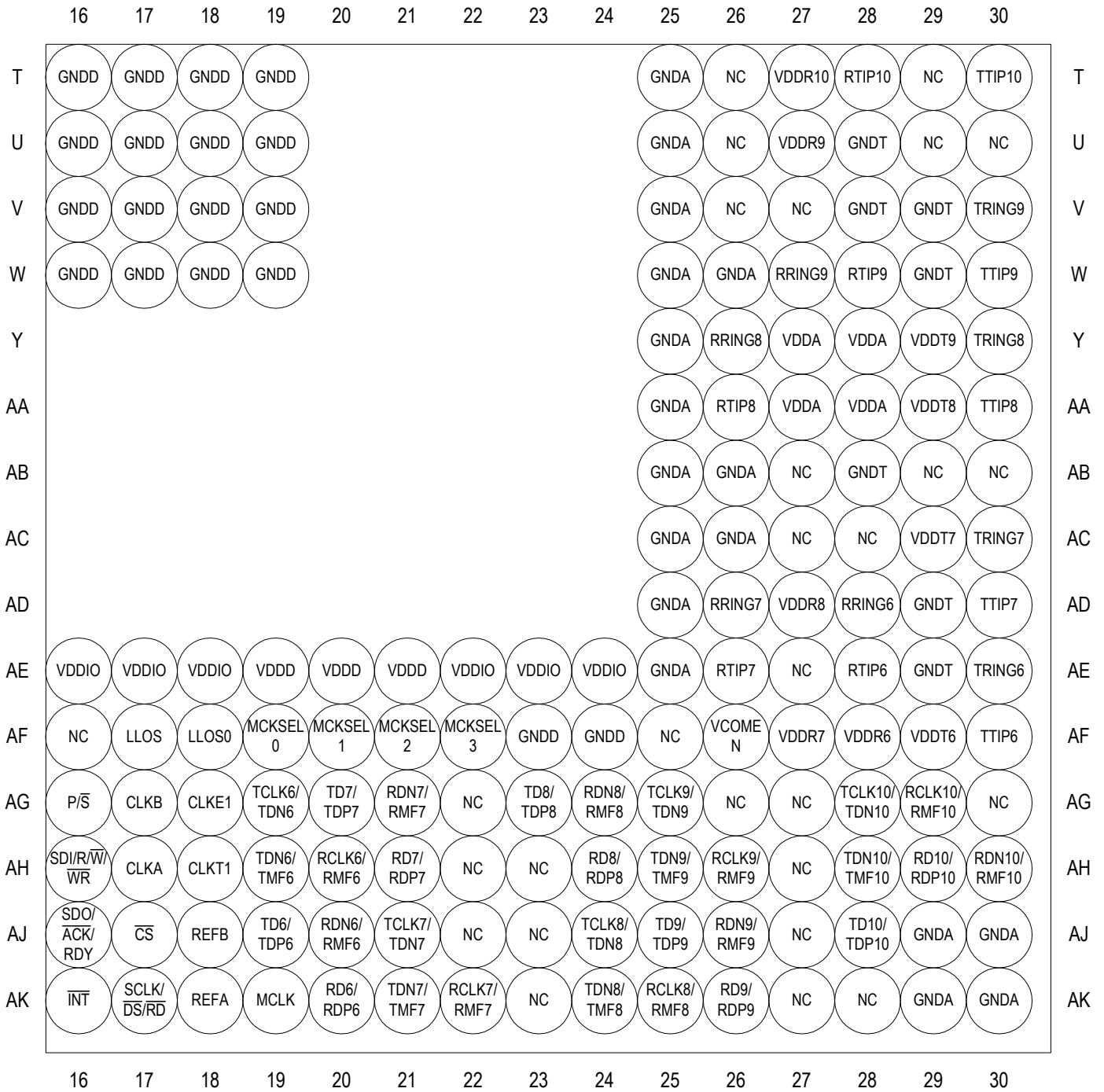

Figure-6 640-Pin TEPBGA (Top View) - Bottom Right

2 PIN DESCRIPTION

Name	I/O	Pin No. ¹	Description
Line Interface			
RTIPn RRINGn (n=0~21)	Input	P3, R5, V4, W5, AA4, AB5, AE28, AE26, AA26, W28, T28, R26, L28, L26, G26, F28, D6, D4, D3, G4, H5, M5 N3, P5, U4, V5, Y4, AA5, AD28, AD26, Y26, W27, R28, P26, K28, K26, F26, E28, E6, D5, E3, F4, G5, L5	<p>RTIPn / RRINGn: Receive Bipolar Tip/Ring for Channel 0 ~ 21</p> <p>The receive line interface supports both Receive Differential mode and Receive Single Ended mode.</p> <p>In Receive Differential mode, the received signal is coupled into RTIPn and RRINGn via a 1:1 transformer or without a transformer (transformer-less).</p> <p>In Receive Single Ended mode, RRINGn should be left open. The received signal is input on RTIPn via a 2:1 (step down) transformer or without a transformer (transformer-less).</p> <p>These pins will become High-Z globally or channel specific in the following conditions:</p> <ul style="list-style-type: none"> • Global High-Z: <ul style="list-style-type: none"> - Connecting the RIM pin to low; - Loss of MCLK - During and after power-on reset, hardware reset or global software reset; • Per-channel High-Z <ul style="list-style-type: none"> - Receiver power down by writing '1' to the R_OFF bit (b5, RCF0,...)
TTIPn TRINGn (n=0~21)	Output	L1, M1, R1, U1, Y1, AA1, AF30, AD30, AA30, W30, T30, P30, L30, J30, F30, D30, A5, A4, A3, C1, F1, J1 K1, M2, R2, T1, W1, AA2, AE30, AC30, Y30, V30, R30, N30, K30, H30, E30, C30, A6, B4, B3, D1, E1, J2	<p>TTIPn / TRINGn: Transmit Bipolar Tip /Ring for Channel 0 ~ 21</p> <p>The transmit line interface supports both Transmit Differential mode and Transmit Single Ended mode.</p> <p>In Transmit Differential mode, TTIPn outputs a positive differential pulse while TRINGn outputs a negative differential pulse. The pulses are coupled to the line side via a 1:2 (step up) transformer or without a transformer (transformer-less).</p> <p>In Transmit Single Ended mode, TRINGn should be left open (it is shorted to ground internally). The signal presented at TTIPn is output to the line side via a 1:2 (step up) transformer.</p> <p>These pins will become High-Z globally or channel specific in the following conditions:</p> <ul style="list-style-type: none"> • Global High-Z: <ul style="list-style-type: none"> - Connecting the OE pin to low; - Loss of MCLK; - During and after power-on reset, hardware reset or global software reset; • Per-channel High-Z <ul style="list-style-type: none"> - Writing '0' to the OE bit (b6, TCF0,...) ²; - Loss of TCLKn in Transmit Single Rail NRZ Format mode or Transmit Dual Rail NRZ Format mode, except that the channel is in Remote Loopback or transmit internal pattern with XCLK ³; - Transmitter power down by writing '1' to the T_OFF bit (b5, TCF0,...); - Per-channel software reset; - The THZ_OC bit (b4, TCF0,...) is set to '1' and the transmit driver over-current is detected. <p>Refer to Section 3.3.8 Output High-Z on TTIP and TRING for details.</p>

Note:

1. The pin number of the pins with the footnote 'n' is listed in order of channel (CH0 ~ CH21).
2. The content in the brackets indicates the position and the register name of the preceding bit. After the register name, if the punctuation '...' is followed, this bit is in a per-channel register. If there is no punctuation following the address, this bit is in a global register or in a channel 0 only register. The addresses and details are included in Chapter 5 Programming Information.
3. XCLK is derived from MCLK. It is 1.544 MHz in T1/J1 mode or 2.048 MHz in E1 mode.

Name	I / O	Pin No.	Description
System Interface			
RDn / RDPn (n=0~21)	Output	AH9, AC4, AG1, AH3, AH6, AK8, AK20, AH21, AH24, AK26, AH29, A27, A24, C23, C20, A18, C17, B15, D14, B12, D11, D8	<p>RDn: Receive Data for Channel 0 ~ 21 When the receive system interface is configured to Single Rail NRZ Format mode, this multiplex pin is used as RDn. The decoded NRZ data is updated on the active edge of RCLKn. The active level on RDn is selected by the RD_INV bit (b3, RCF1,...). When the receiver is powered down, RDn will be in High-Z state or low, as selected by the RHZ bit (b6, RCF0,...).</p> <p>RDPn: Positive Receive Data for Channel 0 ~ 21 When the receive system interface is configured to Dual Rail NRZ Format mode, Dual Rail RZ Format mode or Dual Rail Sliced mode, this multiplex pin is used as RDPn. In Receive Dual Rail NRZ Format mode, the un-decoded NRZ data is output on RDPn and RDNn and updated on the active edge of RCLKn. In Receive Dual Rail RZ Format mode, the un-decoded RZ data is output on RDPn and RDNn and updated on the active edge of RCLKn. In Receive Dual Rail Sliced mode, the raw RZ sliced data is output on RDPn and RDNn. For Receive Differential line interface, an active level on RDPn indicates the receipt of a positive pulse on RTIPn and a negative pulse on RRINGn; while an active level on RDNn indicates the receipt of a negative pulse on RTIPn and a positive pulse on RRINGn. For Receive Single Ended line interface, an active level on RDPn indicates the receipt of a positive pulse on RTIPn; while an active level on RDNn indicates the receipt of a negative pulse on RTIPn. The active level on RDPn and RDNn is selected by the RD_INV bit (b3, RCF1,...). When the receiver is powered down, RDPn and RDNn will be in High-Z state or low, as selected by the RHZ bit (b6, RCF0,...).</p>
RDNn / RMFn (n=0~21)	Output	AG9, AD1, AH1, AG3, AG6, AJ8, AJ20, AG21, AG24, AJ26, AH30, B28, D25, B23, B20, D19, B17, A15, C14, A12, C11, C8	<p>RDNn: Negative Receive Data for Channel 0 ~ 21 When the receive system interface is configured to Dual Rail NRZ Format mode, Dual Rail RZ Format mode or Dual Rail Sliced mode, this multiplex pin is used as RDNn. (Refer to the description of RDPn for details).</p> <p>RMFn: Receive Multiplex Function for Channel 0 ~ 21 When the receive system interface is configured to Single Rail NRZ Format mode, this multiplex pin is used as RMFn. RMFn is configured by the RMF_DEF[2:0] bits (b7~5, RCF1,...) and can indicate PRBS/ARB, LAIS, LEXZ, LBPV, LEXZ+LBPV, LLOS, output recovered clock (RCLK) or XOR output of positive and negative sliced data. Refer to Section 3.5.7.1 RMFn Indication for details. The output on RMFn is updated on the active edge of RCLKn. The active level of RMFn is always high. When the receiver is powered down, RMFn will be in High-Z state or low, as selected by the RHZ bit (b6, RCF0,...).</p>

Name	I / O	Pin No.	Description
RCLKn / RMFn (n=0~21)	Output	AK10, AD2, AH2, AK4, AK7, AH8, AH20, AK22, AK25, AH26, AG29, A28, C25, A23, A20, C19, A17, C16, B14, D13, B11, B8	<p>RCLKn: Receive Clock for Channel 0 ~ 21 When the receive system interface is configured to Single Rail NRZ Format mode, Dual Rail NRZ Format mode or Dual Rail RZ Format mode, this multiplex pin is used as RCLKn. RCLKn outputs a 1.544 MHz (in T1/J1 mode) or 2.048 MHz (in E1 mode) clock which is recovered from the received signal. The data output on RDn and RMFn (in Receive Single Rail NRZ Format mode) or RDPn/RDNn (in Receive Dual Rail NRZ Format mode, Receive Dual Rail RZ Format mode and Receive Dual Rail Sliced) is updated on the active edge of RCLKn. The active edge is selected by the RCK_ES bit (b4, RCF1,...). In LLOS condition, RCLKn output high or XCLK, as selected by the RCKH bit (b7, RCF0,...) (refer to Section 3.5.3.1 Line LOS (LLOS) for details). When the receiver is powered down, RCLKn will be in High-Z state or low, as selected by the RHZ bit (b6, RCF0,...).</p> <p>RMFn: Receive Multiplex Function for Channel 0 ~ 21 When the receive system interface is configured to Dual Rail Sliced mode, this multiplex pin is used as RMFn. (Refer to the description of RMFn of the RDn/RMFn multiplex pin for details).</p>
LLOS	Output	AF17	<p>LLOS: Receive Line Loss Of Signal LLOS synchronizes with the output of CLKE1 and can indicate the LLOS (Line LOS) status of all 22 channels in a serial format. When the clock output on CLKE1 is enabled, LLOS indicates the LLOS status of the 22 channels in a serial format and repeats every twenty-two cycles. Channel 0 is positioned by LLOS0. Refer to the description of LLOS0 below for details. The last 7 redundant clock cycles are low and should be ignored. LLOS is updated on the rising edge of CLKE1 and is always active high. When the clock output of CLKE1 is disabled, LLOS will be held in High-Z state. (Refer to Section 3.5.3.1 Line LOS (LLOS) for details.)</p>
LLOS0	Output	AF18	<p>LLOS0: Receive Line Loss Of Signal for Channel 0 LLOS0 can indicate the position of channel 0 on the LLOS pin. When the clock output on CLKE1 is enabled, LLOS0 pulses high for one CLKE1 clock cycle to indicate the position of channel 0 on the LLOS pin. When CLKE1 outputs 8 KHz clock, LLOS0 pulses high for one 8 KHz clock cycle (125 μs) every twenty-nine 8 KHz clock cycles; when CLKE1 outputs 2.048 MHz clock, LLOS0 pulses high for one 2.048 MHz clock cycle (488 ns) every twenty-nine 2.048 MHz clock cycles. LLOS0 is updated on the rising edge of CLKE1. When the clock output on CLKE1 is disabled, LLOS0 will be held in High-Z state. (Refer to Section 3.5.3.1 Line LOS (LLOS) for details.)</p>

Name	I / O	Pin No.	Description																				
TDn / TDPn (n=0~21)	Input	AG8, AC1, AF1, AG2, AG5, AJ7, AJ19, AG20, AG23, AJ25, AJ28, D27, D24, B22, B19, D18, B16, A14, C13, A11, C10, C7	<p>TDn: Transmit Data for Channel 0 ~ 21 When the transmit system interface is configured to Single Rail NRZ Format mode, this multiplex pin is used as TDn. TDn accepts Single Rail NRZ data. The data is sampled into the device on the active edge of TCLKn. The active level on TDn is selected by the TD_INV bit (b3, TCF1,...).</p> <p>TDPn: Positive Transmit Data for Channel 0 ~ 21 When the transmit system interface is configured to Dual Rail NRZ Format mode or Dual Rail RZ Format mode, this multiplex pin is used as TDPn. In Transmit Dual Rail NRZ Format mode, the pre-encoded NRZ data is input on TDPn and TDNn and sampled on the active edge of TCLKn. In Transmit Dual Rail RZ Format mode, the pre-encoded RZ data is input on TDPn and TDNn. The line code is as follows (when the TD_INV bit (b3, TCF1,...) is '0'):</p> <table border="1"> <thead> <tr> <th>TDPn</th> <th>TDNn</th> <th>Output Pulse on TTIPn</th> <th>Output Pulse on TRINGn *</th> </tr> </thead> <tbody> <tr> <td>0</td> <td>0</td> <td>Space</td> <td>Space</td> </tr> <tr> <td>0</td> <td>1</td> <td>Negative Pulse</td> <td>Positive Pulse</td> </tr> <tr> <td>1</td> <td>0</td> <td>Positive Pulse</td> <td>Negative Pulse</td> </tr> <tr> <td>1</td> <td>1</td> <td>Space</td> <td>Space</td> </tr> </tbody> </table> <p>Note: * For Transmit Single Ended line interface, TRINGn should be open.</p> <p>The active level on TDPn and TDNn is selected by the TD_INV bit (b3, TCF1,...).</p>	TDPn	TDNn	Output Pulse on TTIPn	Output Pulse on TRINGn *	0	0	Space	Space	0	1	Negative Pulse	Positive Pulse	1	0	Positive Pulse	Negative Pulse	1	1	Space	Space
TDPn	TDNn	Output Pulse on TTIPn	Output Pulse on TRINGn *																				
0	0	Space	Space																				
0	1	Negative Pulse	Positive Pulse																				
1	0	Positive Pulse	Negative Pulse																				
1	1	Space	Space																				
TDNn / TMFn (n=0~21)	Input / Output	AK9, AC2, AF2, AK3, AK6, AH7, AH19, AK21, AK24, AH25, AH28, C27, C24, A22, A19, C18, A16, D15, B13, D12, B10, B7	<p>TDNn: Negative Transmit Data for Channel 0 ~ 21 When the transmit system interface is configured to Dual Rail NRZ Format mode, this multiplex pin is used as TDNn. (Refer to the description of TDPn for details).</p> <p>TMFn: Transmit Multiplex Function for Channel 0 ~ 21 When the transmit system interface is configured to Single Rail NRZ Format mode or Dual Rail RZ Format mode, this multiplex pin is used as TMFn. TMFn is configured by the TMF_DEF[2:0] bits (b7~5, TCF1,...) and can indicate PRBS/ARB, SAIS, TOC, TLOS, SEXZ, SBPV, SEXZ+SBPV, SLOS. Refer to Section 3.5.7.2 TMFn Indication for details. The output on TMFn is updated on the active edge of TCLKn (if available). The active level of TMFn is always high.</p>																				
TCLKn / TDNn (n=0~21)	Input	AJ9, AC3, AF3, AJ3, AJ6, AG7, AG19, AJ21, AJ24, AG25, AG28, B27, B24, D23, D20, B18, D17, C15, A13, C12, A10, A7	<p>TCLKn: Transmit Clock for Channel 0 ~ 21 When the transmit system interface is configured to Single Rail NRZ Format mode or Dual Rail NRZ Format mode, this multiplex pin is used as TCLKn. TCLKn inputs a 1.544 MHz (in T1/J1 mode) or 2.048 MHz (in E1 mode) clock. The data input on TDn (in Transmit Single Rail NRZ Format mode) or TDPn/TDNn (in Transmit Dual Rail NRZ Format mode) is sampled on the active edge of TCLKn. The data output on TMFn (in Transmit Single Rail NRZ Format mode) is updated on the active edge of TCLKn. The active edge is selected by the TCK_ES bit (b4, TCF1,...).</p> <p>TDNn: Negative Transmit Data for Channel 0 ~ 21 When the transmit system interface is configured to Dual Rail RZ Format mode, this multiplex pin is used as TDNn. (Refer to the description of TDPn for details).</p>																				

Name	I/O	Pin No.	Description																																		
Clock																																					
MCLK	Input	AK19	<p>MCLK: Master Clock Input MCLK provides a stable reference timing for the IDT82P2821. MCLK should be a clock with +/-32 ppm (in T1/J1 mode) or +/-50 ppm (in E1 mode) accuracy. The clock frequency of MCLK is informed to the device by MCKSEL[3:0]. If MCLK misses (duty cycle is less than 30% for 10 μs) and then recovers, the device will be reset automatically.</p>																																		
MCKSEL[0] MCKSEL[1] MCKSEL[2] MCKSEL[3]	Input	AF19 AF20 AF21 AF22	<p>MCKSEL[3:0]: Master Clock Selection These four pins inform the device of the clock frequency input on MCLK:</p> <table border="1" style="margin-left: auto; margin-right: auto;"> <thead> <tr> <th>MCKSEL[3:0]*</th> <th>Frequency (MHz)</th> </tr> </thead> <tbody> <tr><td>0000</td><td>1.544</td></tr> <tr><td>0001</td><td>1.544 X 2</td></tr> <tr><td>0010</td><td>1.544 X 3</td></tr> <tr><td>0011</td><td>1.544 X 4</td></tr> <tr><td>0100</td><td>1.544 X 5</td></tr> <tr><td>0101</td><td>1.544 X 6</td></tr> <tr><td>0110</td><td>1.544 X 7</td></tr> <tr><td>0111</td><td>1.544 X 8</td></tr> <tr><td>1000</td><td>2.048</td></tr> <tr><td>1001</td><td>2.048 X 2</td></tr> <tr><td>1010</td><td>2.048 X 3</td></tr> <tr><td>1011</td><td>2.048 X 4</td></tr> <tr><td>1100</td><td>2.048 X 5</td></tr> <tr><td>1101</td><td>2.048 X 6</td></tr> <tr><td>1110</td><td>2.048 X 7</td></tr> <tr><td>1111</td><td>2.048 X 8</td></tr> </tbody> </table> <p>Note: 0: GNDD 1: VDDIO</p>	MCKSEL[3:0]*	Frequency (MHz)	0000	1.544	0001	1.544 X 2	0010	1.544 X 3	0011	1.544 X 4	0100	1.544 X 5	0101	1.544 X 6	0110	1.544 X 7	0111	1.544 X 8	1000	2.048	1001	2.048 X 2	1010	2.048 X 3	1011	2.048 X 4	1100	2.048 X 5	1101	2.048 X 6	1110	2.048 X 7	1111	2.048 X 8
MCKSEL[3:0]*	Frequency (MHz)																																				
0000	1.544																																				
0001	1.544 X 2																																				
0010	1.544 X 3																																				
0011	1.544 X 4																																				
0100	1.544 X 5																																				
0101	1.544 X 6																																				
0110	1.544 X 7																																				
0111	1.544 X 8																																				
1000	2.048																																				
1001	2.048 X 2																																				
1010	2.048 X 3																																				
1011	2.048 X 4																																				
1100	2.048 X 5																																				
1101	2.048 X 6																																				
1110	2.048 X 7																																				
1111	2.048 X 8																																				
CLKT1	Output	AH18	<p>CLKT1: 8 KHz / T1 Clock Output The output on CLKT1 can be enabled or disabled, as determined by the CLKT1_EN bit (b1, CLKG). When the output is enabled, CLKT1 outputs an 8 KHz or 1.544 MHz clock, as selected by the CLKT1 bit (b0, CLKG). The output is locked to MCLK. When the output is disabled, CLKT1 is in High-Z state.</p>																																		
CLKE1	Output	AG18	<p>CLKE1: 8 KHz / E1 Clock Output The output on CLKE1 can be enabled or disabled, as determined by the CLKE1_EN bit (b3, CLKG). When the output is enabled, CLKE1 outputs an 8 KHz or 2.048 MHz clock, as selected by the CLKE1 bit (b2, CLKG). The output is locked to MCLK. When the output is disabled, CLKE1 is in High-Z state.</p>																																		

Name	I / O	Pin No.	Description
REFA	Output	AK18	REFA: Reference Clock Output A REFA can output three kinds of clocks: a recovered clock of one of the 22 channels, an external clock input on CLKA or a free running clock. The clock frequency is programmable. Refer to Section 3.6.2 Clock Outputs on REFA/REFB for details. The output on REFA can also be disabled, as determined by the REFA_EN bit (b6, REFA). When the output is disabled, REFA is in High-Z state.
REFB	Output	AJ18	REFB: Reference Clock Output B REFB can output a recovered clock of one of the 22 channels, an external clock input on CLKB or a free running clock. Refer to Section 3.6.2 Clock Outputs on REFA/REFB for details. The output on REFB can also be disabled, as determined by the REFB_EN bit (b6, REFB). When the output is disabled, REFB is in High-Z state.
CLKA	Input	AH17	CLKA: External T1/E1 Clock Input A External T1/J1 (1.544 MHz) or E1 (2.048 MHz) clock is input on this pin. The CKA_T1E1 bit (b5, REFA) should be set to match the clock frequency. When not used, this pin should be connected to GNDD.
CLKB	Input	AG17	CLKB: External T1/E1 Clock Input B External T1/J1 (1.544 MHz) or E1 (2.048 MHz) clock is input on this pin. The CKB_T1E1 bit (b5, REFB) should be set to match the clock frequency. When not used, this pin should be connected to GNDD.
Common Control			
VCOM[0] VCOM[1]	Output	R4 P28	VCOM: Voltage Common Mode [1:0] These pins are used only when the receive line interface is in Receive Differential mode and connected without a transformer (transformer-less). To enable these pins, the VCOMEN pin must be connected high. Refer to Figure-10 for the connection. When these pins are not used, they should be left open.
VCOMEN	Input (Pull-Down)	AF26	VCOMEN: Voltage Common Mode Enable This pin should be connected high only when the receive line interface is in Receive Differential mode and connected without a transformer (transformer-less). When not used, this pin should be left open.
REF	-	D29	REF: Reference Resistor An external resistor (10 K Ω , \pm 1%) is used to connect this pin to ground to provide a standard reference current for internal circuit. This resistor is required to ensure correct device operation.
RIM	Input (Pull-Down)	AH10	RIM: Receive Impedance Matching In Receive Differential mode, when RIM is low, all 22 receivers become High-Z and only external impedance matching is supported. In this case, the per-channel impedance matching configuration bits - the R_TERM[2:0] bits (b2~0, RCF0,...) and the R120IN bit (b4, RCF0,...) - are ignored. In Receive Differential mode, when RIM is high, impedance matching is configured on a per-channel basis by the R_TERM[2:0] bits (b2~0, RCF0,...) and the R120IN bit (b4, RCF0,...). This pin can be used to control the receive impedance state for Hitless Protection applications. Refer to Section 4.4 Hitless Protection Switching (HPS) Summary for details. In Receive Single Ended mode, this pin should be left open.

Name	I / O	Pin No.	Description
OE	Input	AJ10	OE: Output Enable OE enables or disables all Line Drivers globally. A high level on this pin enables all Line Drivers while a low level on this pin places all Line Drivers in High-Z state and independent from related register settings. Note that the functionality of the internal circuit is not affected by OE. If this pin is not used, it should be tied to VDDIO. This pin can be used to control the transmit impedance state for Hitless protection applications. Refer to Section 4.4 Hitless Protection Switching (HPS) Summary for details.
TEHWE	Input (Pull-Up)	AF11	TEHWE: Hardware T1/J1 or E1 Mode Selection Enable When this pin is open, the T1/J1 or E1 operation mode is selected by TEHW globally. When this pin is low, the T1/J1 or E1 operation mode is selected by the T1E1 bit (b0, CHCF,...) on a per-channel basis.
TEHW	Input (Pull-Up)	AF12	TEHW: Hardware T1/J1 or E1 Mode Selection When TEHWE is open, this pin selects the T1/J1 or E1 operation mode globally: Low - E1 mode; Open - T1/J1 mode. When TEHWE is low, the input on this pin is ignored.
GPIO[0] GPIO[1]	Output / Input	AF9 AF10	GPIO: General Purpose I/O [1:0] These two pins can be defined as input pins or output pins by the DIR[1:0] bits (b1~0, GPIO) respectively. When the pins are input, their polarities are indicated by the LEVEL[1:0] bits (b3~2, GPIO) respectively. When the pins are output, their polarities are controlled by the LEVEL[1:0] bits (b3~2, GPIO) respectively.
$\overline{\text{RST}}$	Input	AG10	$\overline{\text{RST}}$: Reset (Active Low) A low pulse on this pin resets the device. This hardware reset process completes in 2 μs maximum. Refer to Section 4.1 Reset for an overview on reset options.
MCU Interface			
$\overline{\text{INT}}$	Output	AK16	$\overline{\text{INT}}$: Interrupt Request This pin indicates interrupt requests for all unmasked interrupt sources. The output characteristics (open drain or push-pull internally) and the active level are determined by the INT_PIN[1:0] bits (b3~2, GCF).
$\overline{\text{CS}}$	Input	AJ17	$\overline{\text{CS}}$: Chip Select (Active Low) This pin must be asserted low to enable the microprocessor interface. A transition from high to low must occur on this pin for each Read/Write operation and $\overline{\text{CS}}$ should remain low until the operation is over.
$\overline{\text{P/S}}$	Input	AG16	$\overline{\text{P/S}}$: Parallel or Serial Microprocessor Interface Select $\overline{\text{P/S}}$ selects Serial or Parallel microprocessor interface for the device: GNDD - Serial microprocessor interface. VDDIO - Parallel microprocessor interface. Serial microprocessor interface consists of the $\overline{\text{CS}}$, SCLK, SDI, SDO pins. Parallel microprocessor interface consists of the $\overline{\text{CS}}$, INT/MOT, IM, $\overline{\text{DS/RD}}$, ALE/AS, R/W/WR, ACK/RDY, D[7:0], A[10:0] pins.
INT/MOT	Input (Pull-Up)	AF14	INT/MOT: Intel or Motorola Microprocessor Interface Select In Parallel microprocessor interface, INT/MOT selects Intel or Motorola microprocessor interface for the device: GNDD - Parallel Motorola microprocessor interface. Open - Parallel Intel microprocessor interface. In Serial microprocessor interface, this pin should be left open.

Name	I / O	Pin No.	Description
IM	Input (Pull-Up)	AF15	<p>IM: Interface Mode Selection In Parallel Motorola or Intel microprocessor interface, IM selects multiplexed bus or non-multiplexed bus for the device: GNDD - Parallel Motorola /Intel Non-Multiplexed microprocessor interface. Open - Parallel Motorola /Intel Multiplexed microprocessor interface. In Serial microprocessor interface, this pin should be connected to GNDD.</p>
ALE / AS	Input	AG15	<p>ALE: Address Latch Enable In Parallel Intel Multiplexed microprocessor interface, this multiplex pin is used as ALE. The address on A[10:8] and D[7:0] (A[7:0] are ignored) is sampled into the device on the falling edges of ALE.</p> <p>AS: Address Strobe In Parallel Motorola Multiplexed microprocessor interface, this multiplex pin is used as AS. The address on A[10:8] and D[7:0] (A[7:0] are ignored) is latched into the device on the falling edges of AS.</p> <p>In Parallel Motorola /Intel Non-Multiplexed microprocessor interface, this pin should be pulled high. In Serial microprocessor interface, this pin should be connected to GNDD.</p>
SCLK / \overline{DS} / \overline{RD}	Input	AK17	<p>SCLK: Shift Clock In Serial microprocessor interface, this multiplex pin is used as SCLK. SCLK inputs the shift clock for the Serial microprocessor interface. Data on SDI is sampled by the device on the rising edge of SCLK. Data on SDO is updated on the falling edge of SCLK.</p> <p>\overline{DS}: Data Strobe (Active Low) In Parallel Motorola microprocessor interface, this multiplex pin is used as \overline{DS}. During a write operation ($R/\overline{W} = 0$), data on D[7:0] is sampled into the device. During a read operation ($R/\overline{W} = 1$), data is driven to D[7:0] by the device.</p> <p>\overline{RD}: Read Strobe (Active Low) In Parallel Intel microprocessor interface, this multiplex pin is used as \overline{RD}. \overline{RD} is asserted low by the microprocessor to initiate a read operation. Data is driven to D[7:0] by the device during the read operation.</p>
SDI / R/\overline{W} / \overline{WR}	Input	AH16	<p>SDI: Serial Data Input In Serial microprocessor interface, this multiplex pin is used as SDI. Address and data on this pin are serially clocked into the device on the rising edge of SCLK.</p> <p>R/\overline{W}: Read / Write Select In Parallel Motorola microprocessor interface, this multiplex pin is used as R/\overline{W}. R/\overline{W} is asserted low for write operation or high for read operation.</p> <p>\overline{WR}: Write Strobe (Active Low) In Parallel Intel microprocessor interface, this multiplex pin is used as \overline{WR}. \overline{WR} is asserted low by the microprocessor to initiate a write operation. Data on D[7:0] is sampled into the device during a write operation.</p>