



Chipsmall Limited consists of a professional team with an average of over 10 year of expertise in the distribution of electronic components. Based in Hongkong, we have already established firm and mutual-benefit business relationships with customers from,Europe,America and south Asia,supplying obsolete and hard-to-find components to meet their specific needs.

With the principle of “Quality Parts,Customers Priority,Honest Operation,and Considerate Service”,our business mainly focus on the distribution of electronic components. Line cards we deal with include Microchip,ALPS,ROHM,Xilinx,Pulse,ON,Everlight and Freescale. Main products comprise IC,Modules,Potentiometer,IC Socket,Relay,Connector.Our parts cover such applications as commercial,industrial, and automotives areas.

We are looking forward to setting up business relationship with you and hope to provide you with the best service and solution. Let us make a better world for our industry!



Contact us

Tel: +86-755-8981 8866 Fax: +86-755-8427 6832

Email & Skype: info@chipsmall.com Web: www.chipsmall.com

Address: A1208, Overseas Decoration Building, #122 Zhenhua RD., Futian, Shenzhen, China





QUAD E1 SHORT HAUL LINE INTERFACE UNIT

IDT82V2054

FEATURES

- ◆ Fully integrated quad E1 short haul line interface which supports 120 Ω twisted pair and 75 Ω coaxial applications
- ◆ Selectable Single Rail mode or Dual Rail mode and AMI or HDB3 encoder/decoder
- ◆ Built-in transmit pre-equalization meets G.703
- ◆ Selectable transmit/receive jitter attenuator meets ETSI CTR12/13, ITU G.736, G.742 and G.823 specifications
- ◆ SONET/SDH optimized jitter attenuator meets ITU G.783 mapping jitter specification
- ◆ Digital/Analog LOS detector meets ITU G.775 and ETS 300 233
- ◆ ITU G.772 non-intrusive monitoring for in-service testing for any one of channel 1 to channel 3
- ◆ Low impedance transmit drivers with high-Z
- ◆ Selectable hardware and parallel/serial host interface
- ◆ Local and Remote Loopback test functions
- ◆ Hitless Protection Switching (HPS) for 1 + 1 protection without relays
- ◆ JTAG boundary scan for board test
- ◆ 3.3 V supply with 5 V tolerant I/O
- ◆ Low power consumption
- ◆ Operating temperature range: -40°C to +85°C
- ◆ Available in 144-pin Thin Quad Flat Pack (TQFP) and 160-pin Plastic Ball Grid Array (PBGA) packages
- ◆ Green package options available

FUNCTIONAL BLOCK DIAGRAM

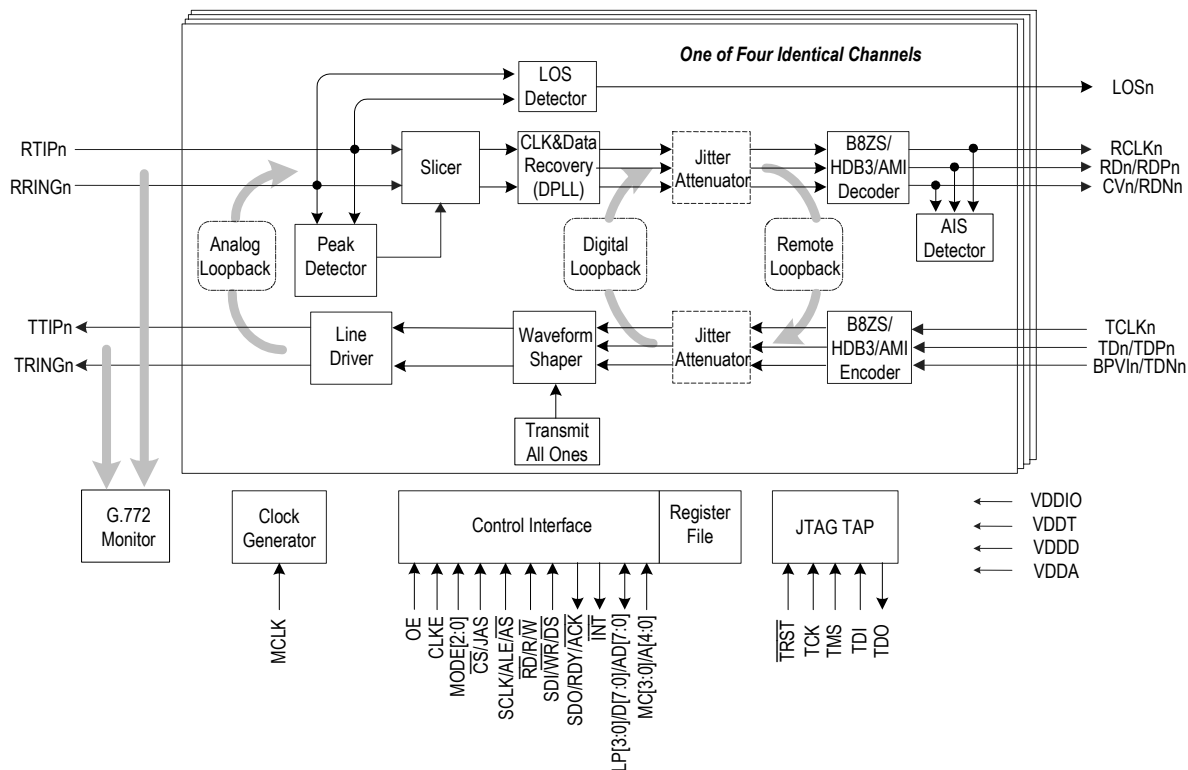

Figure-1 Block Diagram

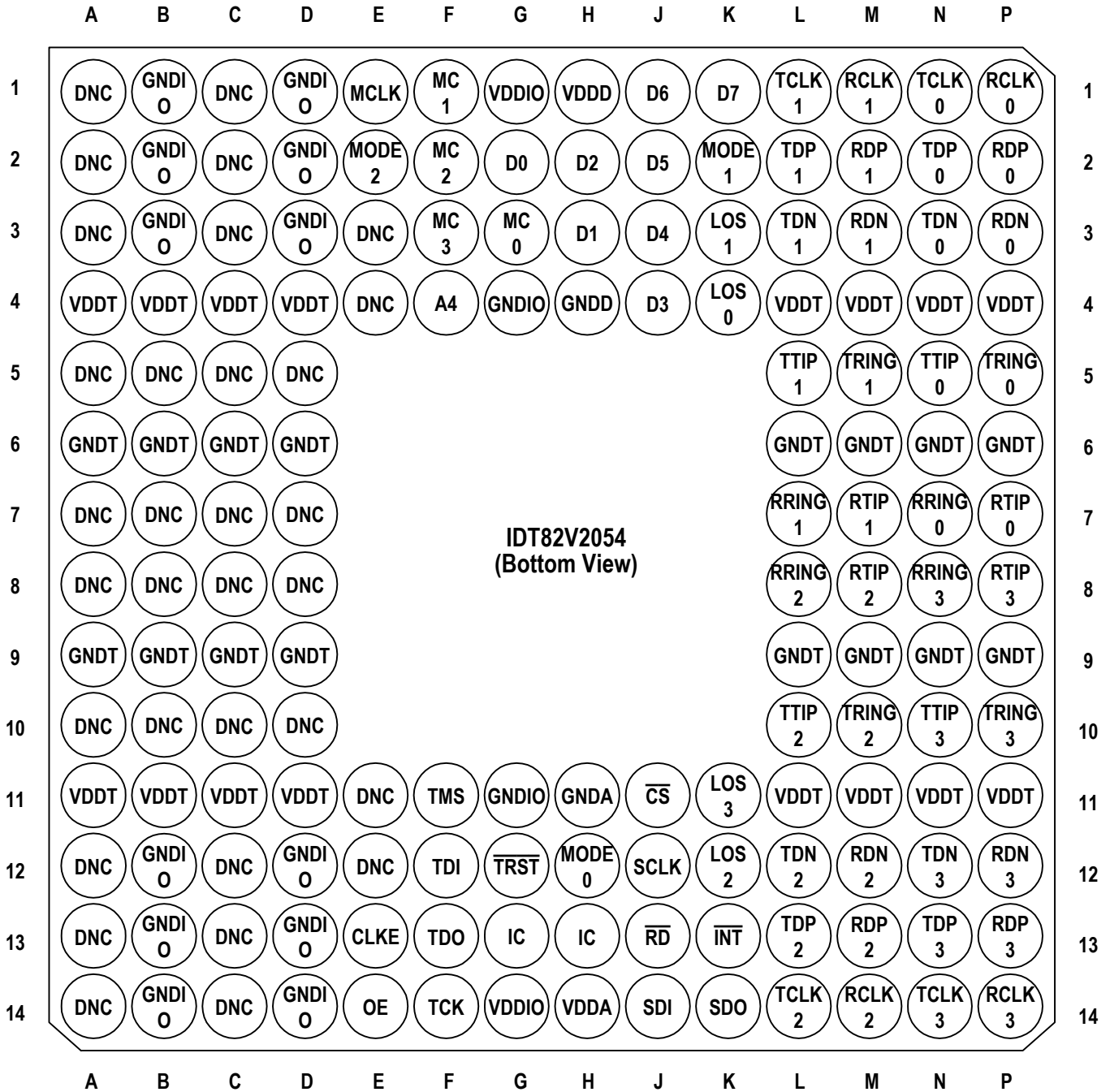

Figure-3 PBGA160 Package Pin Assignment

1 PIN DESCRIPTION

Table-1 Pin Description

Name	Type	Pin No.		Description																	
		TQFP144	PBGA160																		
Transmit and Receive Line Interface																					
TTIP0 TTIP1 TTIP2 TTIP3 TRING0 TRING1 TRING2 TRING3	Analog Output	45 52 57 64 46 51 58 63	N5 L5 L10 N10 P5 M5 M10 P10	TTIPn/TRINGn: Transmit Bipolar Tip/Ring for Channel 0~3 These pins are the differential line driver outputs. They will be in high-Z state if pin OE is low or the corresponding pin TCLKn is low (pin OE is global control, while pin TCLKn is per-channel control). In host mode, each pin can be in high-Z by programming a '1' to the corresponding bit in register OE ⁽¹⁾ .																	
RTIP0 RTIP1 RTIP2 RTIP3 RRING0 RRING1 RRING2 RRING3		Analog Input	48 55 60 67 49 54 61 66	P7 M7 M8 P8 N7 L7 L8 N8	RTIPn/RRINGn: Receive Bipolar Tip/Ring for Channel 0~3 These pins are the differential line receiver inputs.																
Transmit and Receive Digital Data Interface																					
TD0/TDP0 TD1/TDP1 TD2/TDP2 TD3/TDP3 BPV10/TDN0 BPV11/TDN1 BPV12/TDN2 BPV13/TDN3			I	37 30 80 73 38 31 79 72	N2 L2 L13 N13 N3 L3 L12 N12	<p>TDn: Transmit Data for Channel 0~3 When the device is in Single Rail mode, the NRZ data to be transmitted is input on this pin. Data on TDn is sampled into the device on the falling edges of TCLKn, and encoded by AMI or HDB3 line code rules before being transmitted to the line.</p> <p>BPVn: Bipolar Violation Insertion for Channel 0~3 Bipolar violation insertion is available in Single Rail mode 2 (see Table-2 on page 13 and Table-3 on page 14) with AMI enabled. A low-to-high transition on this pin will make the next logic one to be transmitted on TDn the same polarity as the previous pulse, and violate the AMI rule. This is for testing.</p> <p>TDPn/TDNn: Positive/Negative Transmit Data for Channel 0~3 When the device is in Dual Rail Mode, the NRZ data to be transmitted for positive/negative pulse is input on this pin. Data on TDPn/TDNn are sampled on the falling edges of TCLKn. The line code in dual rail mode is as the follow:</p> <table border="1" style="margin-left: auto; margin-right: auto;"> <thead> <tr> <th>TDPn</th> <th>TDNn</th> <th>Output Pulse</th> </tr> </thead> <tbody> <tr> <td>0</td> <td>0</td> <td>Space</td> </tr> <tr> <td>0</td> <td>1</td> <td>Negative Pulse</td> </tr> <tr> <td>1</td> <td>0</td> <td>Positive Pulse</td> </tr> <tr> <td>1</td> <td>1</td> <td>Space</td> </tr> </tbody> </table> <p>Pulling pin TDNn high for more than 16 consecutive TCLK clock cycles will configure the corresponding channel into Single Rail mode 1 (see Table-2 on page 13 and Table-3 on page 14).</p>	TDPn	TDNn	Output Pulse	0	0	Space	0	1	Negative Pulse	1	0	Positive Pulse	1	1	Space
TDPn				TDNn	Output Pulse																
0				0	Space																
0				1	Negative Pulse																
1				0	Positive Pulse																
1	1			Space																	

¹. Register name is indicated by bold capital letter. For example, **OE** indicates Output Enable Register.

Table-1 Pin Description (Continued)

Name	Type	Pin No.		Description																														
		TQFP144	PBGA160																															
<p>TCLK0 TCLK1 TCLK2 TCLK3</p>	I	<p>36 29 81 74</p>	<p>N1 L1 L14 N14</p>	<p>TCLKn: Transmit Clock for Channel 0~3 The clock of 2.048 MHz for transmit is input on this pin. The transmit data at TDn/TDPn or TDNn is sampled into the device on the falling edges of TCLKn. Pulling TCLKn high for more than 16 MCLK cycles, the corresponding transmitter is set in Transmit All Ones (TAOS) state (when MCLK is clocked). In TAOS state, the TAOS generator adopts MCLK as the clock reference. If TCLKn is low, the corresponding transmit channel is set into power down state, while driver output ports become high-Z. Different combinations of TCLKn and MCLK result in different transmit mode. It is summarized as the follows:</p> <table border="1"> <thead> <tr> <th>MCLK</th> <th>TCLKn</th> <th colspan="2">Transmit Mode</th> </tr> </thead> <tbody> <tr> <td>Clocked</td> <td>Clocked</td> <td colspan="2">Normal operation</td> </tr> <tr> <td>Clocked</td> <td>High (≥ 16 MCLK)</td> <td colspan="2">Transmit All Ones (TAOS) signals to the line side in the corresponding transmit channel.</td> </tr> <tr> <td>Clocked</td> <td>Low (≥ 64 MCLK)</td> <td colspan="2">The corresponding transmit channel is set into power down state.</td> </tr> <tr> <td rowspan="4">High/Low</td> <td rowspan="4">TCLK1 is clocked</td> <td>TCLKn is clocked</td> <td>Normal operation</td> </tr> <tr> <td>TCLKn is high (≥ 16 TCLK1)</td> <td>Transmit All Ones (TAOS) signals to the line side in the corresponding transmit channel.</td> </tr> <tr> <td>TCLKn is low (≥ 64 TCLK1)</td> <td>Corresponding transmit channel is set into power down state.</td> </tr> <tr> <td colspan="2">The receive path is not affected by the status of TCLK1. When MCLK is high, all receive paths just slice the incoming data stream. When MCLK is low, all the receive paths are powered down.</td> </tr> <tr> <td>High/Low</td> <td>TCLK1 is unavailable.</td> <td colspan="2">All four transmitters (TTIPn & TRINGn) will be in high-Z.</td> </tr> </tbody> </table>	MCLK	TCLKn	Transmit Mode		Clocked	Clocked	Normal operation		Clocked	High (≥ 16 MCLK)	Transmit All Ones (TAOS) signals to the line side in the corresponding transmit channel.		Clocked	Low (≥ 64 MCLK)	The corresponding transmit channel is set into power down state.		High/Low	TCLK1 is clocked	TCLKn is clocked	Normal operation	TCLKn is high (≥ 16 TCLK1)	Transmit All Ones (TAOS) signals to the line side in the corresponding transmit channel.	TCLKn is low (≥ 64 TCLK1)	Corresponding transmit channel is set into power down state.	The receive path is not affected by the status of TCLK1. When MCLK is high, all receive paths just slice the incoming data stream. When MCLK is low, all the receive paths are powered down.		High/Low	TCLK1 is unavailable.	All four transmitters (TTIPn & TRINGn) will be in high-Z.	
MCLK	TCLKn	Transmit Mode																																
Clocked	Clocked	Normal operation																																
Clocked	High (≥ 16 MCLK)	Transmit All Ones (TAOS) signals to the line side in the corresponding transmit channel.																																
Clocked	Low (≥ 64 MCLK)	The corresponding transmit channel is set into power down state.																																
High/Low	TCLK1 is clocked	TCLKn is clocked	Normal operation																															
		TCLKn is high (≥ 16 TCLK1)	Transmit All Ones (TAOS) signals to the line side in the corresponding transmit channel.																															
		TCLKn is low (≥ 64 TCLK1)	Corresponding transmit channel is set into power down state.																															
		The receive path is not affected by the status of TCLK1. When MCLK is high, all receive paths just slice the incoming data stream. When MCLK is low, all the receive paths are powered down.																																
High/Low	TCLK1 is unavailable.	All four transmitters (TTIPn & TRINGn) will be in high-Z.																																
<p>RD0/RDP0 RD1/RDP1 RD2/RDP2 RD3/RDP3</p> <p>CV0/RDN0 CV1/RDN1 CV2/RDN2 CV3/RDN3</p>	<p>O</p> <p>High-Z</p>	<p>40 33 77 70</p> <p>41 34 76 69</p>	<p>P2 M2 M13 P13</p> <p>P3 M3 M12 P12</p>	<p>RDn: Receive Data for Channel 0~3 In Single Rail mode, the received NRZ data is output on this pin. The data is decoded by AMI or HDB3 line code rule.</p> <p>CVn: Code Violation for Channel 0~3 In Single Rail mode, the bipolar violation, code violation and excessive zeros will be reported by driving pin CVn high for a full clock cycle. However, only bipolar violation is indicated when AMI decoder is selected.</p> <p>RDPn/RDNn: Positive/Negative Receive Data for Channel 0~3 In Dual Rail Mode with clock recovery, these pins output the NRZ data. A high signal on RDPn indicates the receipt of a positive pulse on RTIPn/RRINGn while a high signal on RDNn indicates the receipt of a negative pulse on RTIPn/RRINGn. The output data at RDn or RDPn/RDNn are clocked out on the falling edges of RCLK when the CLKE input is low, or are clocked out on the rising edges of RCLK when CLKE is high. In Dual Rail Mode without clock recovery, these pins output the raw RZ sliced data. In this data recovery mode, the active polarity of RDPn/RDNn is determined by pin CLKE. When pin CLKE is low, RDPn/RDNn is active low. When pin CLKE is high, RDPn/RDNn is active high. In hardware mode, RDn or RDPn/RDNn will remain active during LOS. In host mode, these pins will either remain active or insert alarm indication signal (AIS) into the receive path, determined by bit AISE in register GCF. RDn or RDPn/RDNn is set into high-Z when the corresponding receiver is powered down.</p>																														

Table-1 Pin Description (Continued)

Name	Type	Pin No.		Description																		
		TQFP144	PBGA160																			
RCLK0 RCLK1 RCLK2 RCLK3	O High-Z	39 32 78 71	P1 M1 M14 P14	RCLKn: Receive Clock for Channel 0~3 In clock recovery mode, this pin outputs the recovered clock from signal received on RTIPn/RRINGn. The received data are clocked out of the device on the rising edges of RCLKn if pin CLKE is high, or on falling edges of RCLKn if pin CLKE is low. In data recovery mode, RCLKn is the output of an internal exclusive OR (XOR) which is connected with RDPn and RDNn. The clock is recovered from the signal on RCLKn. If Receiver n is powered down, the corresponding RCLKn is in high-Z.																		
MCLK	I	10	E1	MCLK: Master Clock This is an independent, free running reference clock. A clock of 2.048 MHz is supplied to this pin as the clock reference of the device for normal operation. In receive path, when MCLK is high, the device slices the incoming bipolar line signal into RZ pulse (Data Recovery mode). When MCLK is low, all the receivers are powered down, and the output pins RCLKn, RDPn and RDNn are switched to high-Z. In transmit path, the operation mode is decided by the combination of MCLK and TCLKn (see TCLKn pin description for details). NOTE: Wait state generation via RDY/ $\overline{\text{ACK}}$ is not available if MCLK is not provided.																		
LOS0 LOS1 LOS2 LOS3	O	42 35 75 68	K4 K3 K12 K11	LOSn: Loss of Signal Output for Channel 0~3 A high level on this pin indicates the loss of signal when there is no transition over a specified period of time or no enough ones density in the received signal. The transition will return to low automatically when there is enough transitions over a specified period of time with a certain ones density in the received signal. The LOS assertion and desertion criteria are described in 2.3.4 Loss of Signal (LOS) Detection .																		
Hardware/Host Control Interface																						
MODE2	I (Pulled to VDDIO/2)	11	E2	MODE2: Control Mode Select 2 The signal on this pin determines which control mode is selected to control the device: <table border="1" style="margin-left: auto; margin-right: auto;"> <thead> <tr> <th>MODE2</th> <th>Control Interface</th> </tr> </thead> <tbody> <tr> <td>Low</td> <td>Hardware Mode</td> </tr> <tr> <td>VDDIO/2</td> <td>Serial Host Interface</td> </tr> <tr> <td>High</td> <td>Parallel Host Interface</td> </tr> </tbody> </table> Hardware control pins include MODE[2:0], LP[3:0], CODE, CLKE, JAS and OE. Serial host Interface pins include $\overline{\text{CS}}$, SCLK, SDI, SDO and $\overline{\text{INT}}$. Parallel host Interface pins include $\overline{\text{CS}}$, A[4:0], D[7:0], $\overline{\text{WR}}/\overline{\text{DS}}$, $\overline{\text{RD}}/\overline{\text{RW}}$, $\overline{\text{ALE}}/\overline{\text{AS}}$, $\overline{\text{INT}}$ and RDY/ $\overline{\text{ACK}}$. The device supports multiple parallel host interface as follows (refer to <i>MODE1</i> and <i>MODE0</i> pin descriptions below for details): <table border="1" style="margin-left: auto; margin-right: auto;"> <thead> <tr> <th>MODE[2:0]</th> <th>Host Interface</th> </tr> </thead> <tbody> <tr> <td>100</td> <td>Non-multiplexed Motorola Interface</td> </tr> <tr> <td>101</td> <td>Non-multiplexed Intel Interface</td> </tr> <tr> <td>110</td> <td>Multiplexed Motorola Interface</td> </tr> <tr> <td>111</td> <td>Multiplexed Intel Interface</td> </tr> </tbody> </table>	MODE2	Control Interface	Low	Hardware Mode	VDDIO/2	Serial Host Interface	High	Parallel Host Interface	MODE[2:0]	Host Interface	100	Non-multiplexed Motorola Interface	101	Non-multiplexed Intel Interface	110	Multiplexed Motorola Interface	111	Multiplexed Intel Interface
MODE2	Control Interface																					
Low	Hardware Mode																					
VDDIO/2	Serial Host Interface																					
High	Parallel Host Interface																					
MODE[2:0]	Host Interface																					
100	Non-multiplexed Motorola Interface																					
101	Non-multiplexed Intel Interface																					
110	Multiplexed Motorola Interface																					
111	Multiplexed Intel Interface																					
MODE1	I	43	K2	MODE1: Control Mode Select 1 In parallel host mode, the parallel interface operates with separate address bus and data bus when this pin is low, and operates with multiplexed address and data bus when this pin is high. In serial host mode or hardware mode, this pin should be grounded.																		

Table-1 Pin Description (Continued)

Name	Type	Pin No.		Description								
		TQFP144	PBGA160									
MODE0/CODE	I	88	H12	<p>MODE0: Control Mode Select 0 In parallel host mode, the parallel host interface is configured for Motorola compatible hosts when this pin is low, or for Intel compatible hosts when this pin is high.</p> <p>CODE: Line Code Rule Select In hardware control mode, the HDB3 encoder/decoder is enabled when this pin is low, and AMI encoder/decoder is enabled when this pin is high. The selections affect all the channels.</p> <p>In serial host mode, this pin should be grounded.</p>								
$\overline{\text{CS}}$ /JAS	I (Pulled to VDDIO/2)	87	J11	<p>$\overline{\text{CS}}$: Chip Select (Active Low) In host mode, this pin is asserted low by the host to enable host interface. A high to low transition must occur on this pin for each read/write operation and the level must not return to high until the operation is over.</p> <p>JAS: Jitter Attenuator Select In hardware control mode, this pin globally determines the Jitter Attenuator position:</p> <table border="1"> <thead> <tr> <th>JAS</th> <th>Jitter Attenuator (JA) Configuration</th> </tr> </thead> <tbody> <tr> <td>Low</td> <td>JA in transmit path</td> </tr> <tr> <td>VDDIO/2</td> <td>JA not used</td> </tr> <tr> <td>High</td> <td>JA in receive path</td> </tr> </tbody> </table>	JAS	Jitter Attenuator (JA) Configuration	Low	JA in transmit path	VDDIO/2	JA not used	High	JA in receive path
JAS	Jitter Attenuator (JA) Configuration											
Low	JA in transmit path											
VDDIO/2	JA not used											
High	JA in receive path											
SCLK/ALE/ $\overline{\text{AS}}$	I	86	J12	<p>SCLK: Shift Clock In serial host mode, the signal on this pin is the shift clock for the serial interface. Data on pin SDO is clocked out on falling edges of SCLK if pin CLKE is high, or on rising edges of SCLK if pin CLKE is low. Data on pin SDI is always sampled on rising edges of SCLK.</p> <p>ALE: Address Latch Enable In parallel Intel multiplexed host mode, the address on AD[4:0] is sampled into the device on the falling edges of ALE (signals on AD[7:5] are ignored). In non-multiplexed host mode, ALE should be pulled high.</p> <p>$\overline{\text{AS}}$: Address Strobe (Active Low) In parallel Motorola multiplexed host mode, the address on AD[4:0] is latched into the device on the falling edges of $\overline{\text{AS}}$ (signals on AD[7:5] are ignored). In non-multiplexed host mode, $\overline{\text{AS}}$ should be pulled high. NOTE: This pin is ignored in hardware control mode.</p>								
$\overline{\text{RD}}$ /R $\overline{\text{W}}$	I	85	J13	<p>$\overline{\text{RD}}$: Read Strobe (Active Low) In parallel Intel multiplexed or non-multiplexed host mode, this pin is active low for read operation.</p> <p>R$\overline{\text{W}}$: Read/Write Select In parallel Motorola multiplexed or non-multiplexed host mode, the pin is active low for write operation and high for read operation. NOTE: This pin is ignored in hardware control mode.</p>								

Table-1 Pin Description (Continued)

Name	Type	Pin No.		Description								
		TQFP144	PBGA160									
SDI/ \overline{WR} / \overline{DS}	I	84	J14	<p>SDI: Serial Data Input In serial host mode, this pin input the data to the serial interface. Data on this pin is sampled on the rising edges of SCLK.</p> <p>\overline{WR}: Write Strobe (Active Low) In parallel Intel host mode, this pin is active low during write operation. The data on D[7:0] (in non-multiplexed mode) or AD[7:0] (in multiplexed mode) is sampled into the device on the rising edges of \overline{WR}.</p> <p>\overline{DS}: Data Strobe (Active Low) In parallel Motorola host mode, this pin is active low. During a write operation ($R/\overline{W} = 0$), the data on D[7:0] (in non-multiplexed mode) or AD[7:0] (in multiplexed mode) is sampled into the device on the rising edges of \overline{DS}. During a read operation ($R/\overline{W} = 1$), the data is driven to D[7:0] (in non-multiplexed mode) or AD[7:0] (in multiplexed mode) by the device on the rising edges of \overline{DS}. In parallel Motorola non-multiplexed host mode, the address information on the 5 bits of address bus A[4:0] are latched into the device on the falling edges of \overline{DS}. NOTE: This pin is ignored in hardware control mode.</p>								
SDO/ \overline{RDY} / \overline{ACK}	O	83	K14	<p>SDO: Serial Data Output In serial host mode, the data is output on this pin. In serial write operation, SDO is always in high-Z. In serial read operation, SDO is in high-Z only when SDI is in address/command byte. Data on pin SDO is clocked out of the device on the falling edges of SCLK if pin CLKE is high, or on the rising edges of SCLK if pin CLKE is low.</p> <p>RDY: Ready Output In parallel Intel host mode, the high level of this pin reports to the host that bus cycle can be completed, while low reports the host must insert wait states.</p> <p>\overline{ACK}: Acknowledge Output (Active Low) In parallel Motorola host mode, the low level of this pin indicates that valid information on the data bus is ready for a read operation or acknowledges the acceptance of the written data during a write operation.</p>								
\overline{INT}	O Open Drain	82	K13	<p>\overline{INT}: Interrupt (Active Low) This is the open drain, active low interrupt output. Three sources may cause the interrupt. Refer to 2.19 Interrupt Handling for details.</p>								
D7/AD7 D6/AD6 D5/AD5 D4/AD4 LP3/D3/AD3 LP2/D2/AD2 LP1/D1/AD1 LP0/D0/AD0	I/O High-Z	28 27 26 25 24 23 22 21	K1 J1 J2 J3 J4 H2 H3 G2	<p>LPn: Loopback Select 3~0 In hardware control mode, pin LPn configures the corresponding channel in different loopback mode, as follows:</p> <table border="1"> <thead> <tr> <th>LPn</th> <th>Loopback Configuration</th> </tr> </thead> <tbody> <tr> <td>Low</td> <td>Remote Loopback</td> </tr> <tr> <td>VDDIO/2</td> <td>No loopback</td> </tr> <tr> <td>High</td> <td>Analog Loopback</td> </tr> </tbody> </table> <p>Refer to 2.12 Loopback Mode for details. In hardware control mode, D4 to D7 should be tied to VDDIO/2.</p> <p>Dn: Data Bus 7~0 In non-multiplexed host mode, these pins are the bi-directional data bus.</p> <p>ADn: Address/Data Bus 7~0 In multiplexed host mode, these pins are the multiplexed bi-directional address/data bus.</p> <p>In serial host mode, these pins should be grounded.</p>	LPn	Loopback Configuration	Low	Remote Loopback	VDDIO/2	No loopback	High	Analog Loopback
LPn	Loopback Configuration											
Low	Remote Loopback											
VDDIO/2	No loopback											
High	Analog Loopback											

Table-1 Pin Description (Continued)

Name	Type	Pin No.		Description																												
		TQFP144	PBGA160																													
A4 MC3/A3 MC2/A2 MC1/A1 MC0/A0	I	12 13 14 15 16	F4 F3 F2 F1 G3	<p>MCn: Performance Monitor Configuration 3~0 In hardware control mode, A4 must be connected to GND. MC[3:0] are used to select one transmitter or receiver of channel 1 to 4 for non-intrusive monitoring. Channel 0 is used as the monitoring channel. If a transmitter is monitored, signals on the corresponding pins TTIPn and TRINGn are internally transmitted to RTIP0 and RRING0. If a receiver is monitored, signals on the corresponding pins RTIPn and RRINGn are internally transmitted to RTIP0 and RRING0. The clock and data recovery circuit in Receiver 0 can then output the monitored clock to pin RCLK0 as well as the monitored data to RDP0 and RDN0 pins. The signals monitored by channel 0 can be routed to TTIP0/TRING0 by activating Remote Loopback in this channel. Performance Monitor Configuration determined by MC[3:0] is shown below. Note that if MC[2:0] = 000, the device is in normal operation of all the channels.</p> <table border="1"> <thead> <tr> <th>MC[3:0]</th> <th>Monitoring Configuration</th> </tr> </thead> <tbody> <tr> <td>0000</td> <td>Normal operation without monitoring</td> </tr> <tr> <td>0001</td> <td>Monitor Receiver 1</td> </tr> <tr> <td>0010</td> <td>Monitor Receiver 2</td> </tr> <tr> <td>0011</td> <td>Monitor Receiver 3</td> </tr> <tr> <td>0100</td> <td rowspan="4">Reserved</td> </tr> <tr> <td>0101</td> </tr> <tr> <td>0110</td> </tr> <tr> <td>0111</td> </tr> <tr> <td>1000</td> <td>Normal operation without monitoring</td> </tr> <tr> <td>1001</td> <td>Monitor Transmitter 1</td> </tr> <tr> <td>1010</td> <td>Monitor Transmitter 2</td> </tr> <tr> <td>1011</td> <td>Monitor Transmitter 3</td> </tr> <tr> <td>1100</td> <td rowspan="4">Reserved</td> </tr> <tr> <td>1101</td> </tr> <tr> <td>1110</td> </tr> <tr> <td>1111</td> </tr> </tbody> </table> <p>An: Address Bus 4~0 When pin MODE1 is low, the parallel host interface operates with separate address and data bus. In this mode, the signal on this pin is the address bus of the host interface.</p>	MC[3:0]	Monitoring Configuration	0000	Normal operation without monitoring	0001	Monitor Receiver 1	0010	Monitor Receiver 2	0011	Monitor Receiver 3	0100	Reserved	0101	0110	0111	1000	Normal operation without monitoring	1001	Monitor Transmitter 1	1010	Monitor Transmitter 2	1011	Monitor Transmitter 3	1100	Reserved	1101	1110	1111
MC[3:0]	Monitoring Configuration																															
0000	Normal operation without monitoring																															
0001	Monitor Receiver 1																															
0010	Monitor Receiver 2																															
0011	Monitor Receiver 3																															
0100	Reserved																															
0101																																
0110																																
0111																																
1000	Normal operation without monitoring																															
1001	Monitor Transmitter 1																															
1010	Monitor Transmitter 2																															
1011	Monitor Transmitter 3																															
1100	Reserved																															
1101																																
1110																																
1111																																
OE	I	114	E14	<p>OE: Output Driver Enable Pulling this pin low can drive all driver output into high-Z for redundancy application without external mechanical relays. In this condition, all other internal circuits remain active.</p>																												
CLKE	I	115	E13	<p>CLKE: Clock Edge Select The signal on this pin determines the active edge of RCLKn and SCLK in clock recovery mode, or determines the active level of RDPn and RDNn in the data recovery mode. See 2.2 Clock Edges on page 14 for details.</p>																												
JTAG Signals																																
$\overline{\text{TRST}}$	I Pull-up	95	G12	<p>$\overline{\text{TRST}}$: JTAG Test Port Reset (Active Low) This is the active low asynchronous reset to the JTAG Test Port. This pin has an internal pull-up resistor and can be left disconnected.</p>																												
TMS	I Pull-up	96	F11	<p>TMS: JTAG Test Mode Select The signal on this pin controls the JTAG test performance and is clocked into the device on the rising edges of TCK. This pin has an internal pull-up resistor and it can be left disconnected.</p>																												
TCK	I	97	F14	<p>TCK: JTAG Test Clock This pin input the clock of the JTAG Test. The data on TDI and TMS are clocked into the device on the rising edges of TCK, while the data on TDO is clocked out of the device on the falling edges of TCK. This pin should be connected to GNDIO or VDDIO pin when unused.</p>																												

Table-1 Pin Description (Continued)

Name	Type	Pin No.		Description
		TQFP144	PBGA160	
TDO	O High-Z	98	F13	TDO: JTAG Test Data Output This pin output the serial data of the JTAG Test. The data on TDO is clocked out of the device on the falling edges of TCK. TDO is a high-Z output signal. It is active only when scanning of data is out. This pin should be left float when unused.
TDI	I Pull-up	99	F12	TDI: JTAG Test Data Input This pin input the serial data of the JTAG Test. The data on TDI is clocked into the device on the rising edges of TCK. This pin has an internal pull-up resistor and it can be left disconnected.
Power Supplies and Grounds				
VDDIO	-	17 92	G1 G14	3.3 V I/O Power Supply
GNDIO	-	1 2 7 8 9 18 91 100 101 102 107 108 109 144	B1 B2 B3 B12 B13 B14 D1 D2 D3 D12 D13 D14 G4 G11	I/O GND
VDDT	-	44 53 56 65 116 125 128 137	A4, A11 B4, B11 C4, C11 D4, D11 L4, L11 M4, M11 N4, N11 P4, P11	3.3 V/5 V Power Supply for Transmitter Driver All VDDT pins must be connected to 3.3 V or all VDDT must be connected to 5 V. It is not allowed to leave any of the VDDT pins open (not-connected) even if the channel is not used.
GNDT	-	47 50 59 62 119 122 131 134	A6, A9 B6, B9 C6, C9 D6, D9 L6, L9 M6, M9 N6, N9 P6, P9	Analog GND for Transmitter Driver
VDDD	-	19	H1	3.3 V Digital Core Power Supply
VDDA	-	90	H14	3.3 V Analog Core Power Supply
GNDD	-	20	H4	Digital Core GND
GNDA	-	89	H11	Analog Core GND

Table-1 Pin Description (Continued)

Name	Type	Pin No.		Description
		TQFP144	PBGA160	
Others				
IC	-	93 94	G13 H13	IC: Internal Connection Internal use. Leave it open for normal operation.
DNC	-	3 4 5 6 103 104 105 106 110 111 112 113 117 118 120 121 123 124 126 127 129 130 132 133 135 136 138 139 140 141 142 143	A1 A2 A3 A5 A7 A8 A10 A12 A13 A14 B5 B7 B8 B10 C1 C2 C3 C5 C7 C8 C10 C12 C13 C14 D5 D7 D8 D10 E3 E4 E11 E12	DNC: Do Not Connect

2 FUNCTIONAL DESCRIPTION

2.1 OVERVIEW

The IDT82V2054 is a fully integrated quad short-haul line interface unit, which contains four transmit and receive channels for use in E1 applications. The receiver performs clock and data recovery. As an option, the raw sliced data (no retiming) can be output to the system. Transmit equalization is implemented with low-impedance output drivers that provide shaped waveforms to the transformer, guaranteeing template conformance. A selectable jitter attenuator may be placed in the receive path or the transmit path. Moreover, multiple testing functions, such as error detection, loopback and JTAG boundary scan are also provided. The device is optimized for flexible software control through a serial or parallel host mode interface. Hardware control is also available. [Figure-1 on page 1](#) shows one of the four identical channels operation.

2.1.1 SYSTEM INTERFACE

The system interface of each channel can be configured to operate in different modes:

1. Single rail interface with clock recovery.
2. Dual rail interface with clock recovery.
3. Dual rail interface with data recovery (that is, with raw data slicing only and without clock recovery).

Each signal pin on system side has multiple functions depending on which operation mode the device is in.

The Dual Rail interface consists of TDPn¹, TDNn, TCLKn, RDPn, RDNn and RCLKn. Data transmitted from TDPn and TDNn appears on TTIPn and TRINGn at the line interface; data received from the RTIPn and RRINGn at the line interface are transferred to RDPn and RDNn while the recovered clock extracting from the received data stream outputs on RCLKn. In Dual Rail operation, the clock/data recovery mode is selectable. Dual Rail interface with clock recovery shown in [Figure-4](#) is a default configuration mode. Dual Rail interface with data recovery is shown in [Figure-5](#). Pin RDPn and RDNn, in this condition, are raw RZ slice output and internally connected to an EXOR which is fed to the RCLKn output for external clock recovery applications.

In Single Rail mode, data transmitted from TDn appears on TTIPn and TRINGn at the line interface. Data received from the RTIPn and RRINGn at the line interface appears on RDn while the recovered clock extracting from the received data stream outputs on RCLKn. When the device is in single rail interface, the selectable AMI or HDB3 line encoder/decoder is available and any code violation in the received data will be indicated at the CVn pin. The Single Rail mode has 2 sub-modes: Single Rail Mode 1 and Single Rail Mode 2. Single Rail Mode 1, whose interface is composed of TDn, TCLKn, RDn, CVn and RCLKn, is realized by pulling pin TDNn high for more than 16 consecutive TCLK cycles. Single Rail Mode 2, whose interface is composed of TDn, TCLKn, RDn, CVn, RCLKn and BPVIn, is realized by setting bit CRS in register **e-CRS**² and bit SING in register **e-SING**. The difference between them is that, in the latter mode bipolar violation can be inserted via pin BPVIn if AMI line code is selected.

The configuration of the Hardware Mode System Interface is summarized in [Table-2](#). The configuration of the Host (Software) Mode System Interface is summarized [Table-3](#).

¹ The footprint 'n' (n = 0 - 3) indicates one of the four channels.

² The first letter 'e-' indicates expanded register.

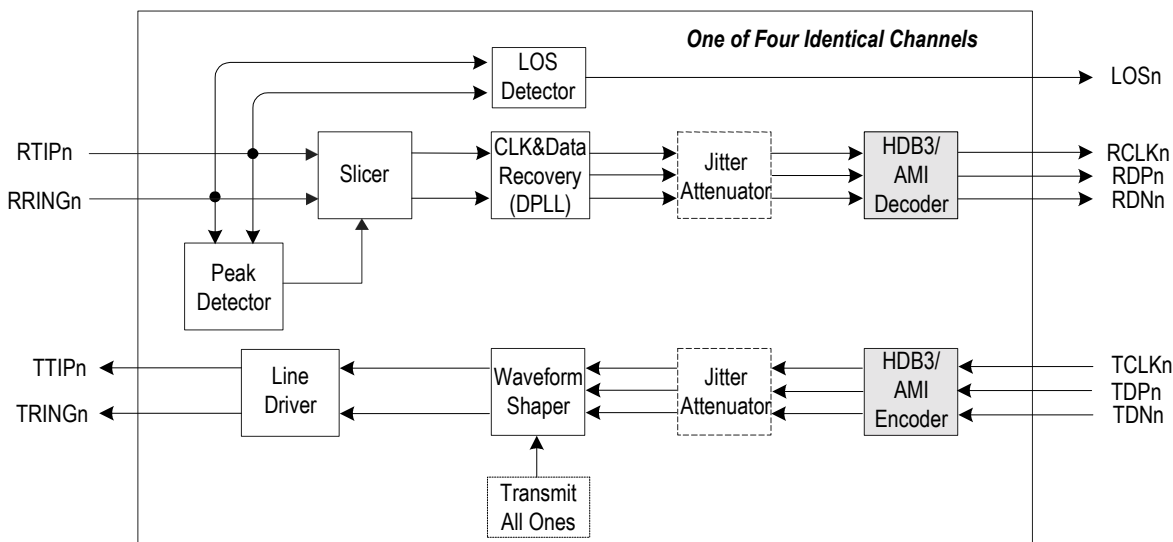

Note: The grey blocks are bypassed and the dotted blocks are selectable.

Figure-4 Dual Rail Interface with Clock Recovery

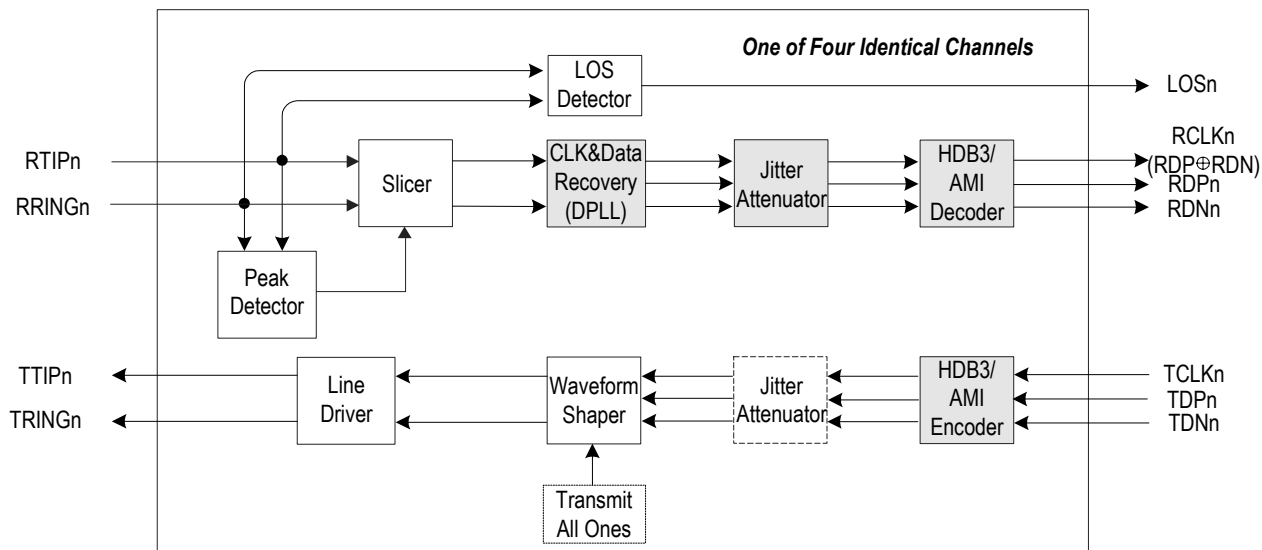

Note: The grey blocks are bypassed and the dotted blocks are selectable

Figure-5 Dual Rail Interface with Data Recovery

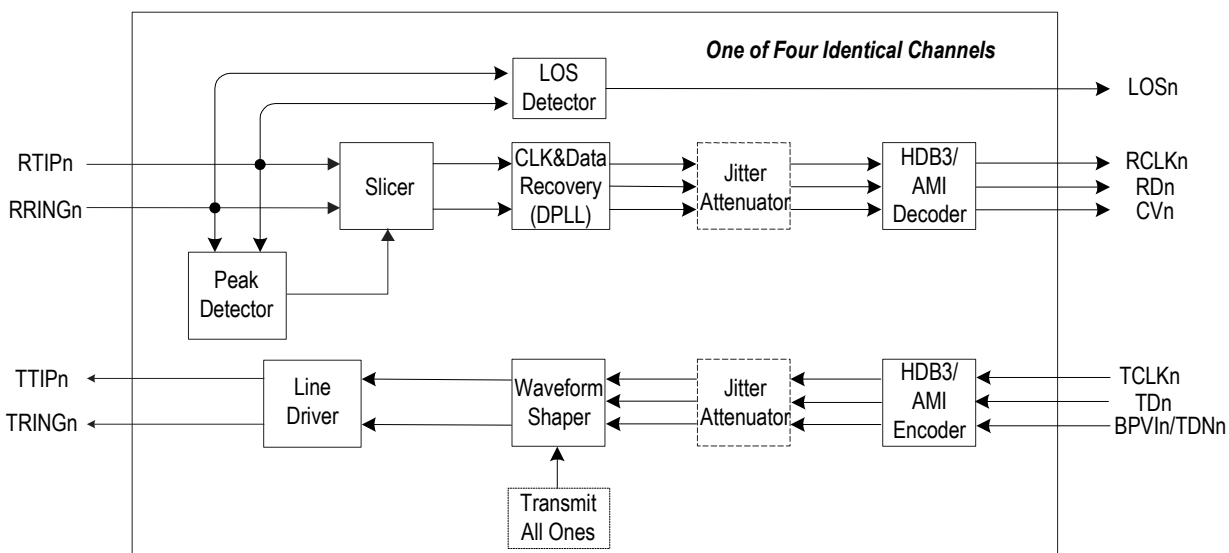

Figure-6 Single Rail Mode





Table-2 System Interface Configuration (In Hardware Mode)

Pin MCLK	Pin TDNn	Interface
Clocked	High (≥ 16 MCLK)	Single Rail Mode 1
Clocked	Pulse	Dual Rail mode with Clock Recovery
High	Pulse	Receive just slices the incoming data. Transmit is determined by the status of TCLKn.
Low	Pulse	Receiver n is powered down. Transmit is determined by the status of TCLKn.

Table-3 System Interface Configuration (In Host Mode)

Pin MCLK	Pin TDNn	CRSn in e-CRS	SINGn in e-SING	Interface
Clocked	High	0	0	Single Rail Mode 1
Clocked	Pulse	0	1	Single Rail Mode 2
Clocked	Pulse	0	0	Dual Rail mode with Clock Recovery
Clocked	Pulse	1	0	Dual Rail mode with Data Recovery
High	Pulse	-	-	Receive just slices the incoming data. Transmit is determined by the status of TCLKn.
Low	Pulse	-	-	Receiver n is powered down. Transmit is determined by the status of TCLKn.

Table-4 Active Clock Edge and Active Level

Pin CLKE	Pin RDn/RDPn and CVn/RDNn			Pin SDO	
	Clock Recovery		Slicer Output		
High	RCLKn 	Active High	Active High	SCLK 	Active High
Low	RCLKn 	Active High	Active Low	SCLK 	Active High

2.2 CLOCK EDGES

The active edge of RCLKn and SCLK are selectable. If pin CLKE is high, the active edge of RCLKn is the rising edge, as for SCLK, that is falling edge. On the contrary, if CLKE is low, the active edge of RCLKn is the falling edge and that of SCLK is rising edge. Pins RDn/RDPn, CVn/RDNn and SDO are always active high, and those output signals are clocked out on the active edge of RCLKn and SCLK respectively. See [Table-4 Active Clock Edge and Active Level on page 14](#) for details. However, in dual rail mode without clock recovery, pin CLKE is used to set the active level for RDPn/RDNn raw slicing output: High for active high polarity and low for active low. It should be noted that data on pin SDI are always active high and are sampled on the rising edges of SCLK. The data on pin TDn/TDPn or BPVIn/TDNn are also always active high but is sampled on the falling edges of TCLK, despite the level on CLKE.

2.3 RECEIVER

In receive path, the line signals couple into RRINGn and RTIPn via a transformer and are converted into RZ digital pulses by a data slicer. Adaptation for attenuation is achieved using an integral peak detector that sets the slicing levels. Clock and data are recovered from the received RZ digital pulses by a digital phase-locked loop that provides jitter accommodation. After passing through the selectable jitter attenuator, the recovered data are decoded using HDB3 or AMI line code rules and clocked out of pin RDn in single rail mode, or presented on RDPn/RDNn in an undecoded dual rail NRZ format. Loss of signal, alarm indication signal, line code violation and excessive zeros are detected. These various changes in status may be enabled to generate interrupts.

2.3.1 PEAK DETECTOR AND SLICER

The slicer determines the presence and polarity of the received pulses. In data recovery mode, the raw positive slicer output appears on RDPn while the negative slicer output appears on RDNn. In clock and data recovery mode, the slicer output is sent to Clock and Data Recovery circuit for abstracting retimed data and optional decoding. The

slicer circuit has a built-in peak detector from which the slicing threshold is derived. The slicing threshold is default to 50% (typical) of the peak value.

Signals with an attenuation of up to 12 dB (from 2.4 V) can be recovered by the receiver. To provide immunity from impulsive noise, the peak detectors are held above a minimum level of 0.150 V typically, despite the received signal level.

2.3.2 CLOCK AND DATA RECOVERY

The Clock and Data Recovery is accomplished by Digital Phase Locked Loop (DPLL). The DPLL is clocked 16 times of the received clock rate, i.e. 32.768 MHz in E1 mode. The recovered data and clock from DPLL is then sent to the selectable Jitter Attenuator or decoder for further processing.

The clock recovery and data recovery can be selected on a per channel basis by setting bit CRSn in register **e-CRS**. When bit CRSn is defaulted to '0', the corresponding channel operates in data and clock recovery mode. The recovered clock is output on pin RCLKn and retimed NRZ data are output on pin RDPn/RDNn in Dual Rail mode or on RDn in single rail mode. When bit CRSn is set to '1', Dual Rail mode with data recovery is enabled in the corresponding channel and the clock recovery is bypassed. In this condition, the analog line signal are converted to RZ digital bit streams on the RDPn/RDNn pins and internally connected to an EXOR which is fed to the RCLKn output for external clock recovery applications.

If pin MCLK is pulled high, all the receivers will enter the Dual Rail mode with data recovery. In this case, register **e-CRS** is ignored.

2.3.3 HDB3/AMI LINE CODE RULE

Selectable HDB3 and AMI line coding/decoding is provided when the device is configured in Single Rail mode. HDB3 rules is enabled by setting bit CODE in register **GCF** to '0' or pulling pin CODE low. AMI rule is enabled by setting bit CODE in register **GCF** to '1' or pulling pin CODE high. The settings affect all four channels.

Line code rule selection for each channel, if needed, is available by setting bit SINGn in register **e-SING** to '1' (to activate bit CODEn in register **e-CODE**) and programming bit CODEn to select line code rules in the corresponding channel: '0' for B8ZS/HDB3, while '1' for AMI. In this case, the value in bit CODE in register **GCF** or pin CODE for global control is unaffected in the corresponding channel and only affect in other channels.

In dual rail mode, the decoder/encoder are bypassed. Bit CODE in register **GCF**, bit CODEn in register **e-CODE** and pin CODE are ignored.

The configuration of the line code rule is summarized in [Table-5](#).

Table-5 Configuration of the Line Code Rule

Hardware Mode	
CODE	Line Code Rule
Low	All channels in HDB3
High	All channels in AMI

2.3.4 LOSS OF SIGNAL (LOS) DETECTION

The Loss of Signal Detector monitors the amplitude and density of the received signal on receiver line before the transformer (measured on port A, B shown in [Figure-10](#)). The loss condition is reported by pulling pin LOSn high. At the same time, LOS alarm registers track LOS condition. When LOS is detected or cleared, an interrupt will generate if not masked. In host mode, the detection supports ITU G.775 and ETSI 300 233. In hardware mode, it supports the ITU G.775.

[Table-6](#) summarizes the conditions of LOS in clock recovery mode.

During LOS, the RDPn/RDNn output the sliced data when bit AISE in register **GCF** is set to '0' or output all ones as AIS (alarm indication signal) when bit AISE is set to '1'. The RCLKn is replaced by MCLK only if the bit AISE is set.

Host Mode			
CODE in GCF	CODEn in e-CODE	SINGn in e-SING	Line Code Rule
0	0/1	0	All channels in HDB3
0	0	1	
1	0/1	0	All channels in AMI
1	1	1	
0	1	1	CHn in AMI
1	0	1	CHn in HDB3

Table-6 LOS Condition in Clock Recovery Mode

		Standard		Signal on LOSn
		G.775	ETSI 300 233	
LOS Detected	Continuous Intervals	32	2048 (1 ms)	High
	Amplitude ⁽¹⁾	below typical 200 mVp	below typical 200 mVp	
LOS Cleared	Density	12.5% (4 marks in a sliding 32-bit period) with no more than 15 continuous zeros	12.5% (4 marks in a sliding 32-bit period) with no more than 15 continuous zeros	Low
	Amplitude ⁽¹⁾	exceed typical 250 mVp	exceed typical 250 mVp	

¹. LOS levels at device (RTIPn, RRINGn) with all ones signal. For more detail regarding the LOS parameters, please refer to [Receiver Characteristics on page 45](#).

2.3.5 ALARM INDICATION SIGNAL (AIS) DETECTION

Alarm Indication Signal is available only in host mode with clock recovery, as shown in [Table-7](#).

Table-7 AIS Condition

	ITU G.775 (Register LAC defaulted to '0')	ETSI 300 233 (Register LAC set to '1')
AIS Detected	Less than 3 zeros contained in each of two consecutive 512-bit stream are received	Less than 3 zeros contained in a 512-bit stream are received
AIS Cleared	3 or more zeros contained in each of two consecutive 512-bit stream are received	3 or more zeros contained in a 512-bit stream are received

2.3.6 ERROR DETECTION

The device can detect excessive zeros, bipolar violation and HDB3 code violation, as shown in [Figure-7](#) and [Figure-8](#). All the three kinds of errors are reported in both host mode and hardware mode with HDB3 line code rule used. In host mode, the **e-CZER** and **e-CODV** are used to

determine whether excessive zeros and code violation are reported respectively. When the device is configured in AMI decoding mode, only bipolar violation can be reported.

The error detection is available only in single rail mode in which the pin CVn/RDNn is used as error report output (CVn pin).

The configuration and report status of error detection are summarized in [Table-8](#).

Table-8 Error Detection

Hardware Mode		Host Mode			
Line Code	Pin CVn Reports	Line Code	CODVn in e-CODV	CZERn in e-CZER	Pin CVn Reports
AMI	Bipolar Violation	AMI	-	-	Bipolar Violation
HDB3	Bipolar Violation + Code Violation + Excessive Zeros	HDB3	0	0	Bipolar Violation + Code Violation
			0	1	Bipolar Violation + Code Violation + Excessive Zeros
			1	0	Bipolar Violation
			1	1	Bipolar Violation + Excessive Zeros

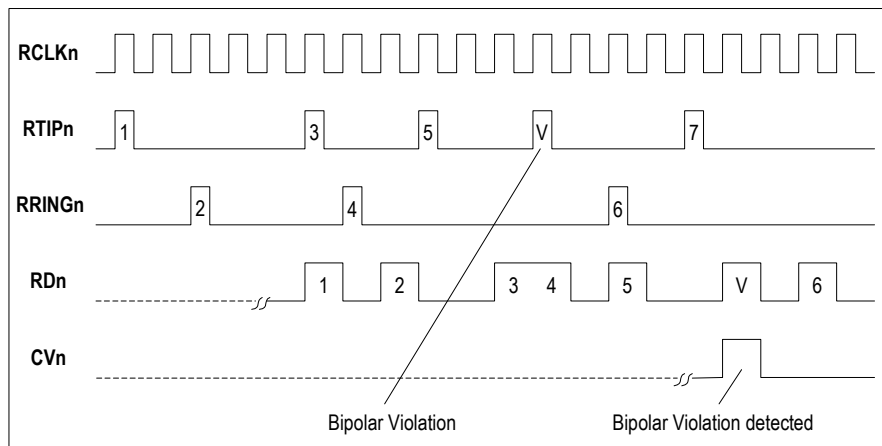

Figure-7 AMI Bipolar Violation

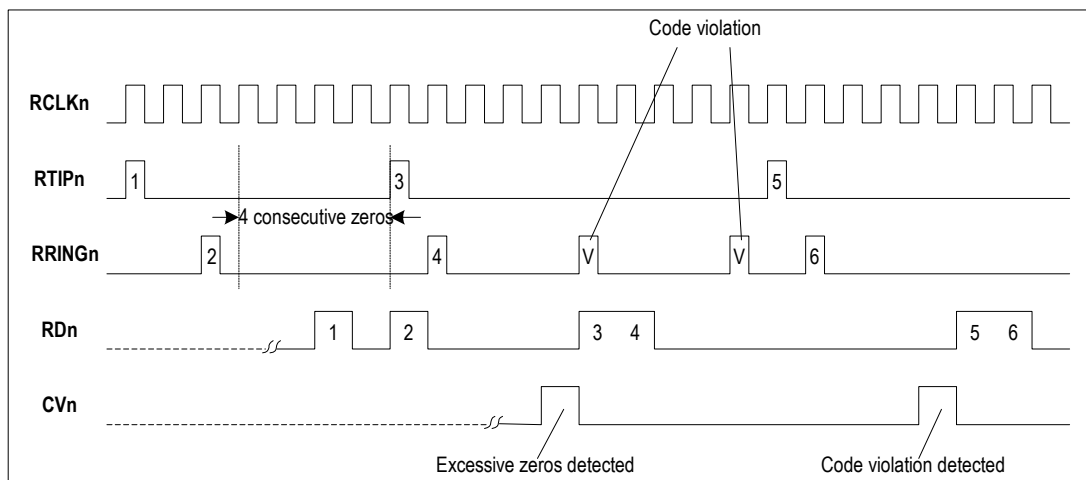

Figure-8 HDB3 Code Violation & Excessive Zeros

2.4 TRANSMITTER

In transmit path, data in NRZ format are clocked into the device on TDn and encoded by AMI or HDB3 line code rules when single rail mode is configured or pre-encoded data in NRZ format are input on TDPn and TDNn when dual rail mode is configured. The data are sampled into the device on falling edges of TCLKn. Jitter attenuator, if enabled, is provided with a FIFO through which the data to be transmitted are passing. A low jitter clock is generated by an integral digital phase-

locked loop and is used to read data from the FIFO. The shape of the pulses should meet the E1 pulse template after the signal passes through different cable lengths or types. Bipolar violation, for diagnosis, can be inserted on pin BPVIn if AMI line code rule is enabled.

2.4.1 WAVEFORM SHAPER

E1 pulse template, specified in ITU-T G.703, is shown in Figure-9. The device has built-in transmit waveform templates for cable of 75 Ω or 120 Ω.

The built-in waveform shaper uses an internal high frequency clock which is 16XMCLK as the clock reference. This function will be bypassed when MCLK is unavailable.

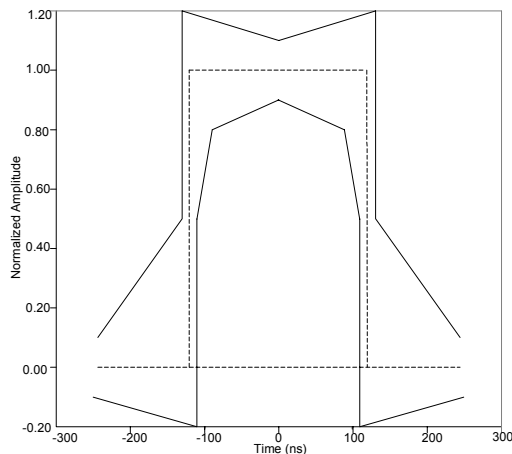

Figure-9 CEPT Waveform Template

2.4.2 BIPOLAR VIOLATION INSERTION

When configured in Single Rail Mode 2 with AMI line code enabled, pin TDNn/BPVIn is used as BPVI input. A low-to-high transition on this pin inserts a bipolar violation on the next available mark in the transmit data stream. Sampling occurs on the falling edges of TCLK. But in TAOS (Transmit All Ones) with Analog Loopback and Remote Loopback, the BPVI is disabled. In TAOS with Digital Loopback, the BPVI is looped back to the system side, so the data to be transmitted on TTINGn and TRINGn are all ones with no bipolar violation.

2.5 JITTER ATTENUATOR

The jitter attenuator can be selected to work either in transmit path or in receive path or not used. The selection is accomplished by setting pin JAS in hardware mode or configuring bits JACF[1:0] in register GCF in host mode which affects all four channels.

For applications which require line synchronization, the line clock needed to be extracted for the internal synchronization, the jitter attenuator is set in the receive path. Another use of the jitter attenuator is to provide clock smoothing in the transmit path for applications such as

synchronous/asynchronous demultiplexing applications. In these applications, TCLK will have an instantaneous frequency that is higher than the nominal E1 data rate and in order to set the average long-term TCLK frequency within the transmit line rate specifications, periods of TCLK are suppressed (gapped).

The jitter attenuator integrates a FIFO which can accommodate a gapped TCLK. In host mode, the FIFO length can be 32 X 2 or 64 X 2 bits by programming bit JADP in GCF. In hardware mode, it is fixed to 64 X 2 bits. The FIFO length determines the maximum permissible gap width (see Table-9 Gap Width Limitation). Exceeding these values will cause FIFO overflow or underflow. The data is 16 or 32 bits' delay through the jitter attenuator in the corresponding transmit or receive path. The constant delay feature is crucial for the applications requiring "hitless" switching.

Table-9 Gap Width Limitation

FIFO Length	Max. Gap Width
64 bit	56 UI
32 bit	28 UI

In host mode, bit JABW in GCF determines the jitter attenuator 3 dB corner frequency (f_c). In hardware mode, the f_c is fixed to 1.7 Hz. Generally, the lower the f_c is, the higher the attenuation. However, lower f_c comes at the expense of increased acquisition time. Therefore, the optimum f_c is to optimize both the attenuation and the acquisition time. In addition, the longer FIFO length results in an increased throughput delay and also influences the 3 dB corner frequency. Generally, it's recommended to use the lower corner frequency and the shortest FIFO length that can still meet jitter attenuation requirements.

The output jitter meets ITU-T G.736, ITU-T G.742, ITU-T G.783 and ETSI CTR 12/13.

2.6 LINE INTERFACE CIRCUITRY

The transmit and receive interface RTIPn/RRINGn and TTIPn/TRINGn connections provide a matched interface to the cable. Figure-10 shows the appropriate external components to connect with the cable for one transmit/receive channel. Table-10 summarizes the component values based on the specific application.

Table-10 External Components Values

Component	75 Ω Coax	120 Ω Twisted Pair
R _T	9.5 Ω ± 1%	9.5 Ω ± 1%
R _R	9.31 Ω ± 1%	15 Ω ± 1%
C _p	2200 pF	
D1 - D4	Nihon Inter Electronics - EP05Q03L, 11EQS03L, EC10QS04, EC10QS03L; Motorola - MBR0540T1	

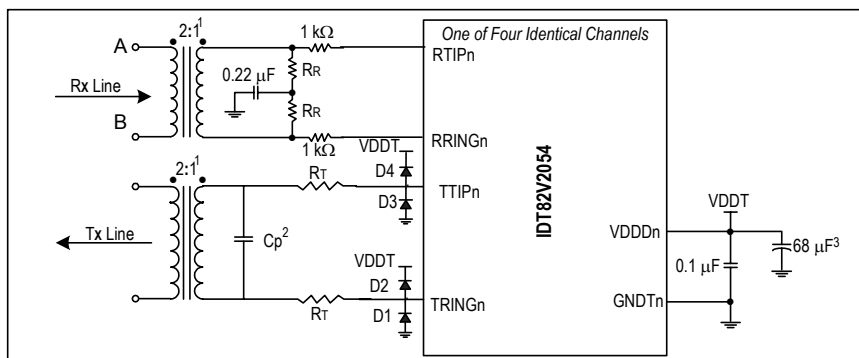

NOTE:

1. Pulse T1124 transformer is recommended to be used in Standard (STD) operating temperature range (0°C to 70°C), while Pulse T1114 transformer is recommended to be used in Extended (EXT) operating temperature range is -40°C to +85°C. See Transformer Specifications Table for details.
2. Typical value. Adjust for actual board parasitics to obtain optimum return loss.
3. Common decoupling capacitor for all VDDT and GNDT pins. One per chip.
4. The R_R and R_T values are listed in Table-10.

Figure-10 External Transmit/Receive Line Circuitry

2.7 TRANSMIT DRIVER POWER SUPPLY

All transmit driver power supplies must be 5.0 V or 3.3 V.

Despite the power supply voltage, the 75 Ω/120 Ω lines are driven through a pair of 9.5 Ω series resistors and a 1:2 transformer.

Table-11 Transformer Specifications⁽¹⁾

Electrical Specification @ 25°C										
Part No.		Turns Ratio (Pri: sec ± 2%)		OCL @ 25°C (mH MIN)		L _L (μH MAX)		C _{www} (pF MAX)		Package/Schematic
STD Temp.	EXT Temp.	Transmit	Receive	Transmit	Receive	Transmit	Receive	Transmit	Receive	
T1124	T1114	1:2CT	1CT:2	1.2	1.2	.6	.6	35	35	TOU/3

¹. Pulse T1124 transformer is recommended to be used in Standard (STD) operating temperature range (0°C to 70°C), while Pulse T1114 transformer is recommended to be used in Extended (EXT) operating temperature range is -40°C to +85°C.

2.8 POWER DRIVER FAILURE MONITOR

An internal power Driver Failure Monitor (DFMON), parallel connected with TTIPn and TRINGn, can detect short circuit failure between TTIPn and TRINGn pins. Bit SCPB in register GCF decides whether the output driver short circuit protection is enabled. When the short circuit protection is enabled, the driver output current is limited to a typical value: 180 mAp. Also, register DF, DFI and DFM will be available. When DFMON will detect a short circuit, register DF will be set. With a short circuit failure detected, register DFI will be set and an interrupt will be generated on pin INT.

However, in harsh cable environment, series resistors are required to improve the transmit return loss performance and protect the device from surges coupling into the device.

2.9 TRANSMIT LINE SIDE SHORT CIRCUIT FAILURE DETECTION

A pair of 9.5 Ω serial resistors connect with TTIPn and TRINGn pins and limit the output current. In this case, the output current is a limited value which is always lower than the typical line short circuit current 180 mAp, even if the transmit line side is shorted.

Refer to [Table-10 External Components Values](#) for details.

2.10 LINE PROTECTION

In transmit side, the Schottky diodes D1~D4 are required to protect the line driver and improve the design robustness. In receive side, the series resistors of 1 k Ω are used to protect the receiver against current surges coupled in the device. The series resistors do not affect the receiver sensitivity, since the receiver impedance is as high as 120 k Ω typically.

2.11 HITLESS PROTECTION SWITCHING (HPS)

The IDT82V2054 transceivers include an output driver with high-Z feature for E1 redundancy applications. This feature reduces the cost of redundancy protection by eliminating external relays. Details of HPS are described in relative Application Note.

2.12 LOOPBACK MODE

The device provides four different diagnostic loopback configurations: Digital Loopback, Analog Loopback, Remote Loopback and Dual Loopback. In host mode, these functions are implemented by programming the registers **DLB**, **ALB** and **RLB** respectively. In hardware mode, only Analog Loopback and Remote Loopback can be selected by pin LPn.

2.12.1 DIGITAL LOOPBACK

By programming the bits of register **DLB**, each channel of the device can be set in Local Digital Loopback. In this configuration, the data and clock to be transmitted, after passing the encoder, are looped back to Jitter Attenuator (if enabled) and decoder in the receive path, then output on RCLKn, RDn/RDPn and CVn/RDNn. The data to be transmitted are still output on TTIPn and TRINGn while the data received on RTIPn and RRINGn are ignored. The Loss Detector is still in use. [Figure-11](#) shows the process.

During Digital Loopback, the received signal on the receive line is still monitored by the LOS Detector (See [2.3.4 Loss of Signal \(LOS\) Detection](#) for details). In case of a LOS condition and AIS insertion enabled, all ones signal will be output on RDPn/RDNn. With ATAO enabled, all ones signal will be also output on TTIPn/TRINGn. AIS insertion can be enabled by setting AISE bit in register **GCF** and ATAO can be enabled by setting register **ATAO** (default disabled).

2.12.2 ANALOG LOOPBACK

By programming the bits of register **ALB** or pulling pin LPn high, each channel of the device can be configured in Analog Loopback. In this configuration, the data to be transmitted output from the line driver

are internally looped back to the slicer and peak detector in the receive path and output on RCLKn, RDn/RDPn and CVn/RDNn. The data to be transmitted are still output on TTIPn and TRINGn while the data received on RTIPn and RRINGn are ignored. The LOS Detector (See [2.3.4 Loss of Signal \(LOS\) Detection](#) for details) is still in use and monitors the internal looped back data. If a LOS condition on TDPn/TDNn is expected during Analog Loopback, ATAO should be disabled (default). [Figure-12](#) shows the process.

The TTIPn and RTIPn, TRINGn and RRINGn cannot be connected directly to do the external analog loopback test. Line impedance loading is required to conduct the external analog loopback test.

2.12.3 REMOTE LOOPBACK

By programming the bits of register **RLB** or pulling pin LPn low, each channel of the device can be configured in Remote Loopback. In this configuration, the data and clock recovered by the clock and data recovery circuits are looped to waveform shaper and output on TTIPn and TRINGn. The jitter attenuator is also included in loopback when enabled in the transmit or receive path. The received data and clock are still output on RCLKn, RDn/RDPn and CVn/RDNn while the data to be transmitted on TCLKn, TDn/TDPn and BPVIn/TDNn are ignored. The LOs Detector is still in use. [Figure-13](#) shows the process.

2.12.4 DUAL LOOPBACK

Dual Loopback mode is set by setting bit DLBn in register **DLB** and bit RLBn in register **RLB** to '1'. In this configuration, after passing the encoder, the data and clock to be transmitted are looped back to decoder directly and output on RCLKn, RDn/RDPn and CVn/RDNn. The recovered data from RTIPn and RRINGn are looped back to waveform shaper through JA (if selected) and output on TTIPn and TRINGn. The LOS Detector is still in use. [Figure-14](#) shows the process.

2.12.5 TRANSMIT ALL ONES (TAOS)

In hardware mode, the TAOS mode is set by pulling pin TCLKn high for more than 16 MCLK cycles. In host mode, TAOS mode is set by programming register **TAO**. In addition, automatic TAOS signals are inserted by setting register **ATAO** when Loss of Signal occurs. Note that the TAOS generator adopts MCLK as a timing reference. In order to assure that the output frequency is within specified limits, MCLK must have the applicable stability.

The TAOS mode, the TAOS mode with Digital Loopback and the TAOS mode with Analog Loopback are shown in [Figure-15](#), [Figure-16](#) and [Figure-17](#).

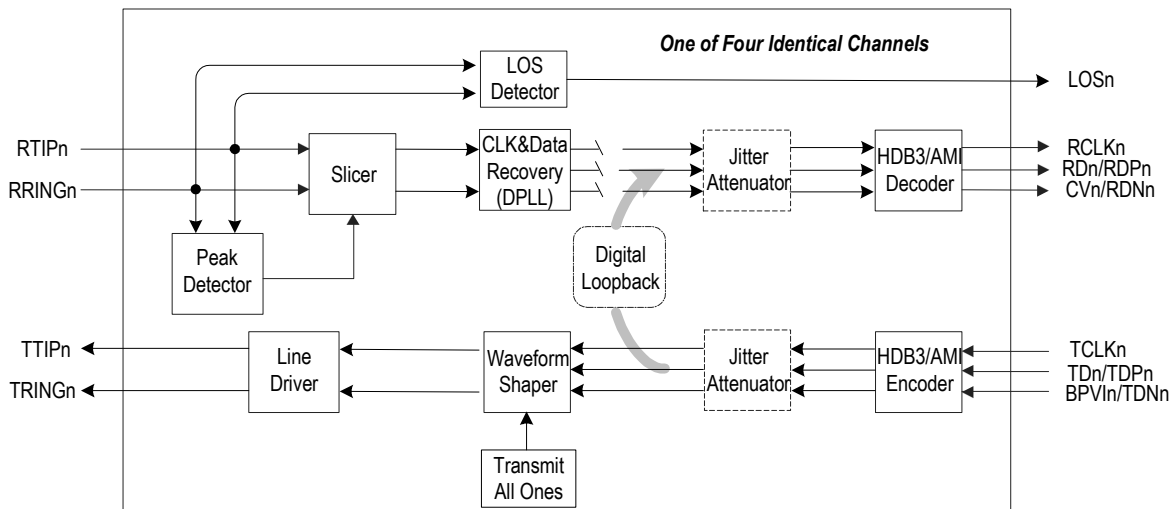

Figure-11 Digital Loopback

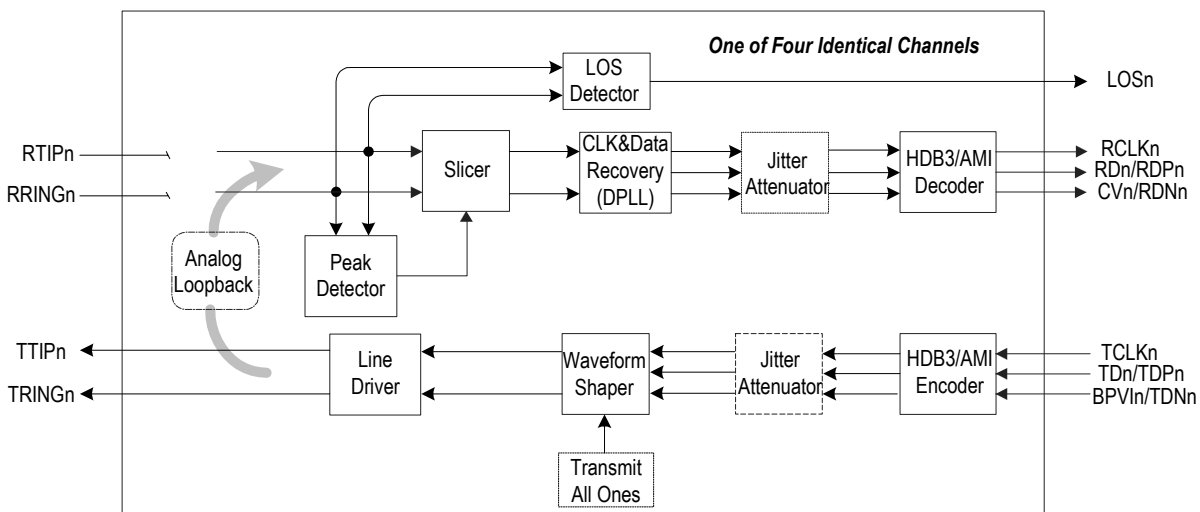

Figure-12 Analog Loopback

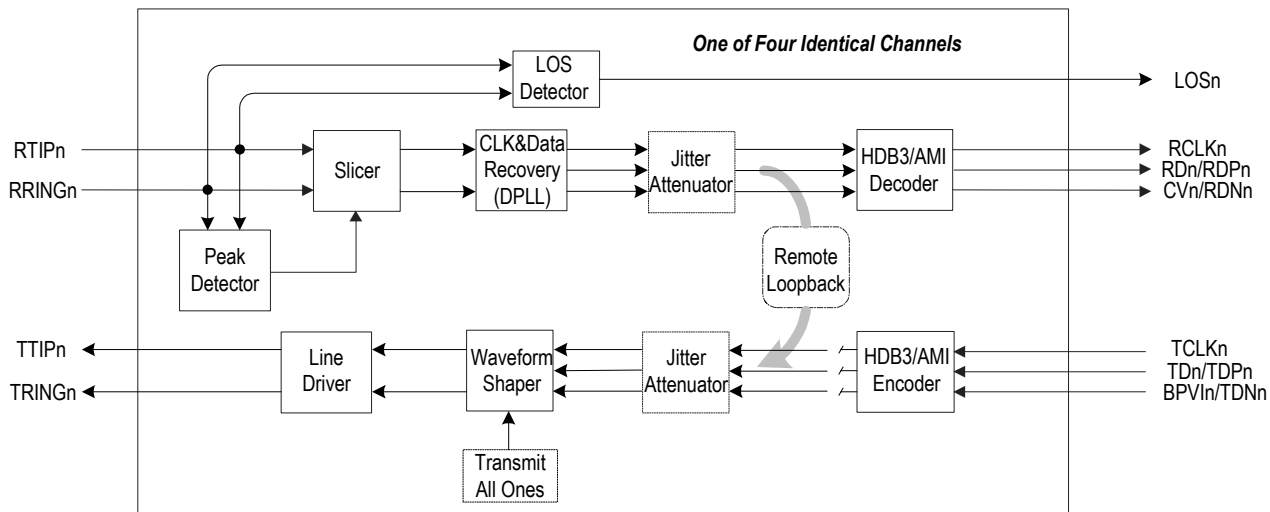

Figure-13 Remote Loopback

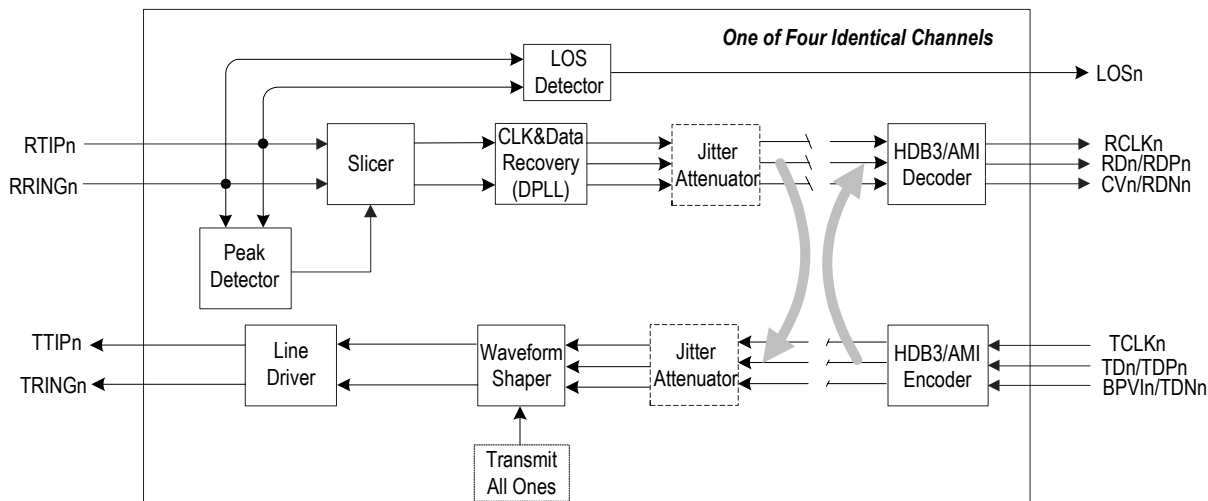

Figure-14 Dual Loopback

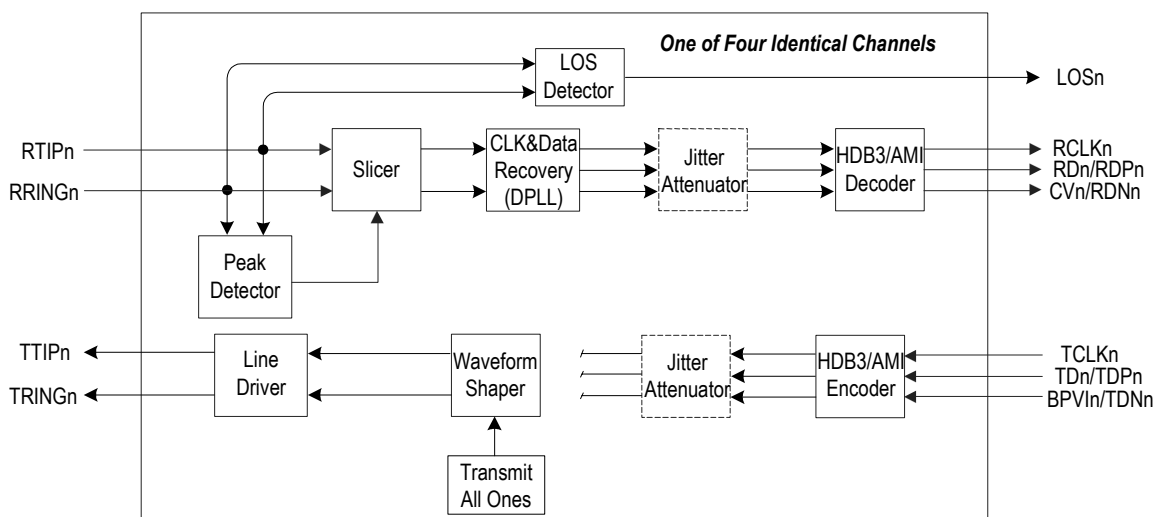

Figure-15 TAOS Data Path

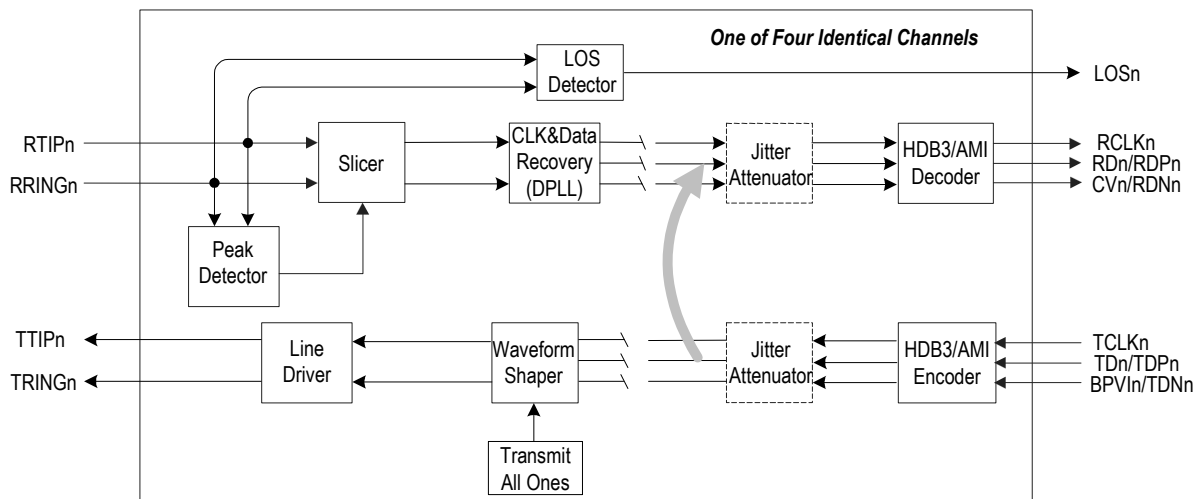

Figure-16 TAOS with Digital Loopback

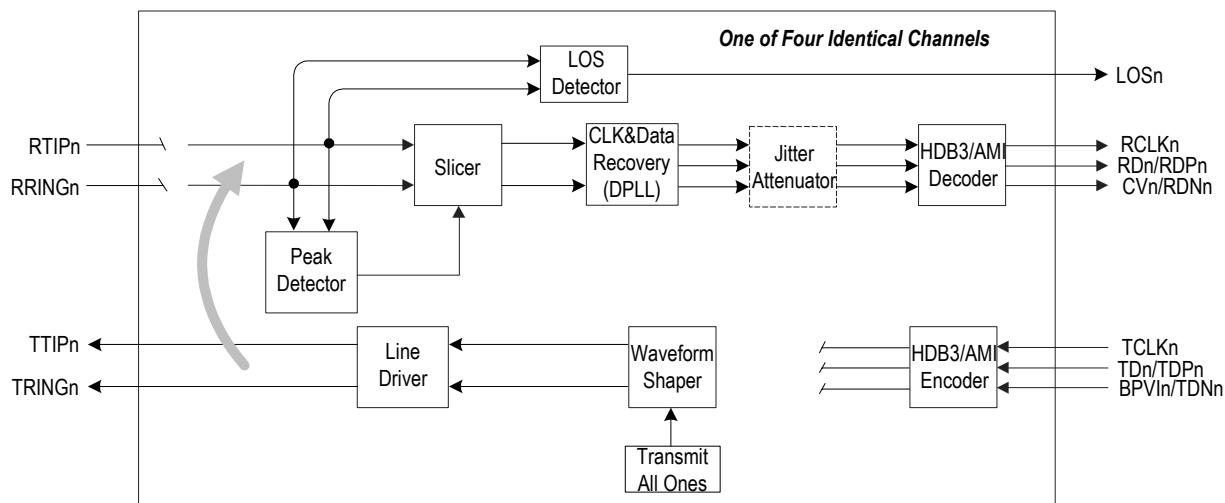

Figure-17 TAOS with Analog Loopback

2.13 G.772 MONITORING

The four channels of IDT82V2054 can all be configured to work as regular transceivers. In applications using only three channels (channels 1 to 3), channel 0 is configured to non-intrusively monitor any of the other channels' inputs or outputs on the line side. The monitoring is non-intrusive per ITU-T G.772. Figure-18 shows the Monitoring Principle. The receive path or transmit path to be monitored is configured by pins MC[3:0] in hardware mode or by register **PMON** in host mode.

The monitored signal goes through the clock and data recovery circuit of channel 0. The monitored clock can output on RCLK0 which can be used as a timing interfaces derived from E1 signal. The monitored data can be observed digitally at the output pins RCLK0, RD0/RDP0 and RDN0. LOS detector is still in use in channel 0 for the monitored signal.

In monitoring mode, channel 0 can be configured in Remote Loopback. The signal which is being monitored will output on TTIP0 and TRING0. The output signal can then be connected to a standard test equipment with an E1 electrical interface for non-intrusive monitoring.

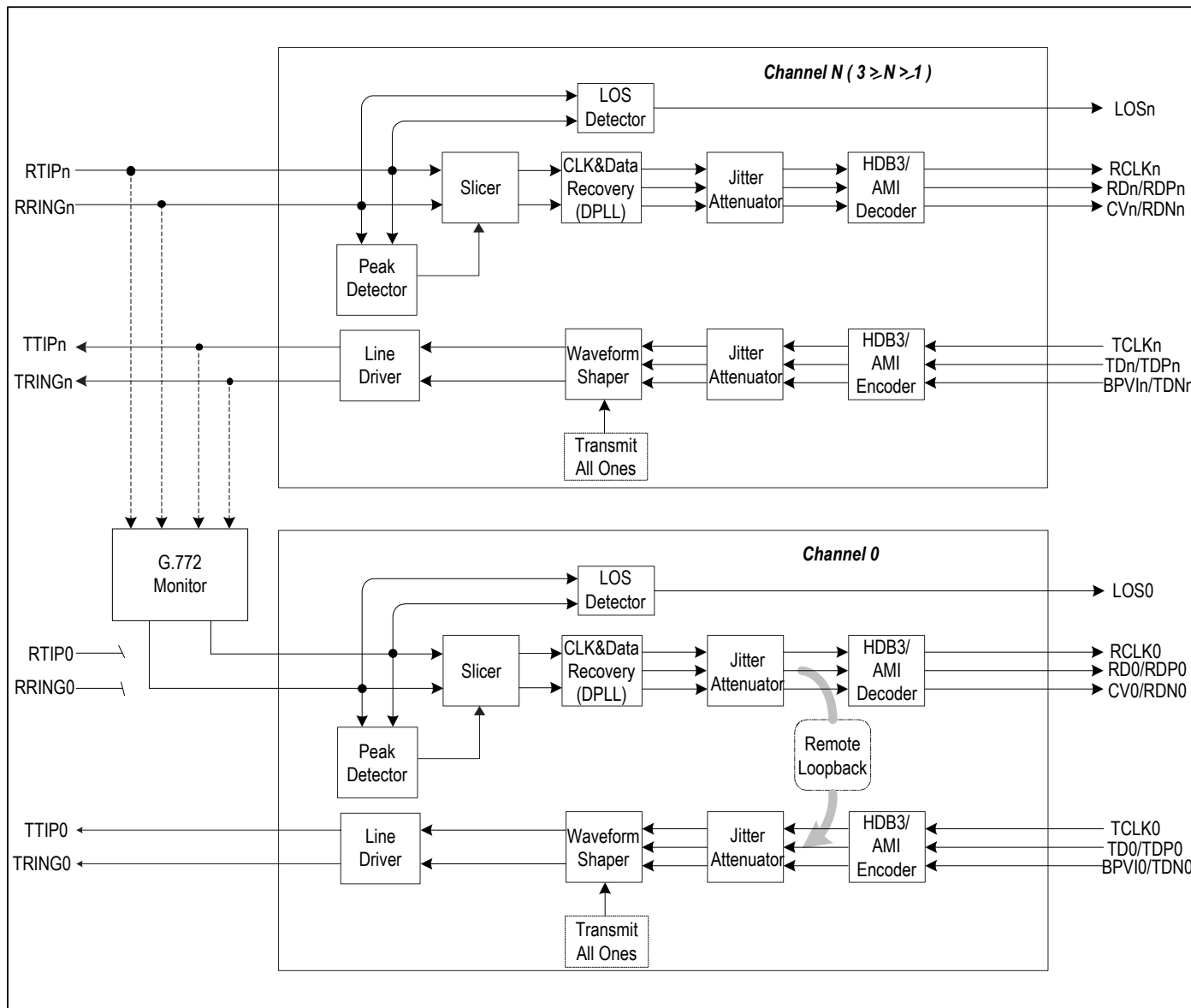

Figure-18 Monitoring Principle

2.14 SOFTWARE RESET

Writing register **RS** will cause software reset by initiating about 1 μ s reset cycle. This operation set all the registers to their default value.

2.15 POWER ON RESET

During power up, an internal reset signal sets all the registers to default values. The power-on reset takes at least 10 μ s, starting from when the power supply exceeds 2/3 VDDA.

2.16 POWER DOWN

Each transmit channel will be powered down by pulling pin TCLKn low for more than 64 MCLK cycles (if MCLK is available) or about 30 μ s (if MCLK is not available). In host mode, each transmit channel will also be powered down by setting bit TPDn in register **e-TPDN** to '1'.

All the receivers will be powered down when MCLK is low. When MCLK is clocked or high, setting bit RPDn in register **e-RPDN** to '1' will configure the corresponding receiver to be powered down.

2.17 INTERFACE WITH 5 V LOGIC

The IDT82V2054 can interface directly with 5 V TTL family devices. The internal input pads are tolerant to 5 V output from TTL and CMOS family devices.

2.18 HOST INTERFACE

The host interface provides access to read and write the registers in the device. The interface consists of serial host interface and parallel host interface. By pulling pin MODE2 to VDDIO/2 or high, the device can be set to work in serial mode and in parallel mode respectively.

2.18.1 PARALLEL HOST INTERFACE

The interface is compatible with Motorola and Intel host. Pins MODE1 and MODE0 are used to select the operating mode of the parallel host interface. When pin MODE1 is pulled low, the host uses separate address bus and data bus. When high, multiplexed address/data bus is used. When pin MODE0 is pulled low, the parallel host interface is configured for Motorola compatible hosts. When pin MODE0 is pulled high, the parallel host interface is configured for Intel compatible hosts. See [Table-1 Pin Description](#) for more details. The host interface pins in each operation mode is tabulated in [Table-12](#):

Table-12 Parallel Host Interface Pins

MODE[2:0]	Host Interface	Generic Control, Data and Output Pin
100	Non-multiplexed Motorola interface	\overline{CS} , \overline{ACK} , \overline{DS} , $\overline{R/W}$, \overline{AS} , A[4:0], D[7:0], \overline{INT}
101	Non-multiplexed Intel interface	\overline{CS} , RDY, \overline{WR} , \overline{RD} , ALE, A[4:0], D[7:0], \overline{INT}
110	Multiplexed Motorola interface	\overline{CS} , \overline{ACK} , \overline{DS} , $\overline{R/W}$, \overline{AS} , AD[7:0], \overline{INT}
111	Multiplexed Intel interface	\overline{CS} , RDY, \overline{WR} , \overline{RD} , ALE, AD[7:0], \overline{INT}

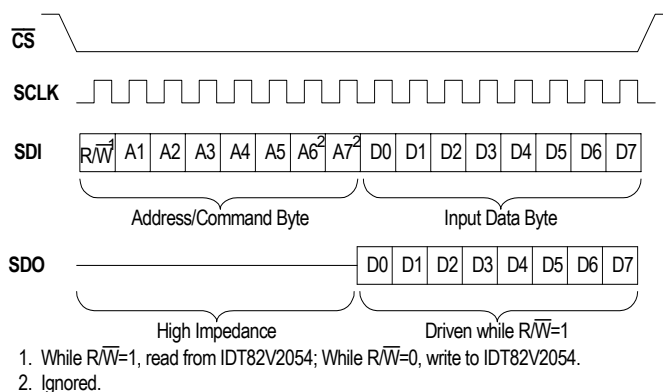

Figure-19 Serial Host Mode Timing

2.18.2 SERIAL HOST INTERFACE

By pulling pin MODE2 to VDDIO/2, the device operates in the serial host Mode. In this mode, the registers are accessible through a 16-bit word which contains an 8-bit command/address byte (bit R/\overline{W} and 5-address-bit A1~A5, A6 and A7 bits are ignored) and a subsequent 8-bit data byte (D7~D0), as shown in [Figure-19](#). When bit R/\overline{W} is set to '1', data is read out from pin SDO. When bit R/\overline{W} is set to '0', data on pin SDI is written into the register whose address is indicated by address bits A5~A1.

2.19 INTERRUPT HANDLING

2.19.1 INTERRUPT SOURCES

There are three kinds of interrupt sources:

1. *Status change in register **LOS**. The analog/digital loss of signal detector continuously monitors the received signal to update the specific bit in register **LOS** which indicates presence or absence of a LOS condition.*
2. *Status change in register **DF**. The automatic power driver circuit continuously monitors the output drivers signal to update the specific bit in register **DFM** which indicates presence or absence of an output driver short circuit condition.*
3. *Status change in register **AIS**. The AIS detector monitors the received signal to update the specific bit in register **AIS** which indicates presence or absence of a AIS condition.*

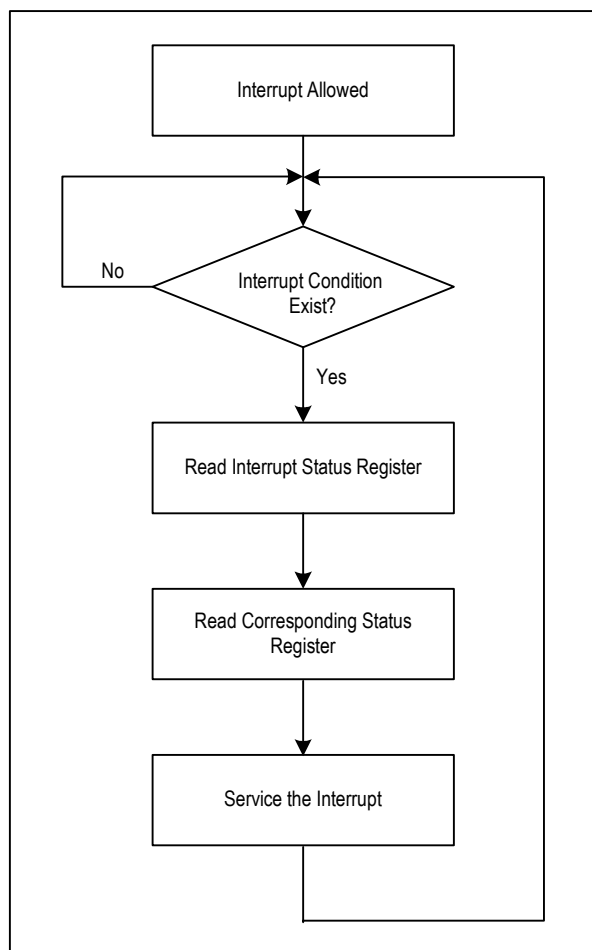

Figure-20 Interrupt Service Routine

2.19.2 INTERRUPT ENABLE

The IDT82V2054 provides a latched interrupt output ($\overline{\text{INT}}$) and the four kinds of interrupts are all reported by this pin. When the Interrupt Mask register (**LOSM**, **DFM** and **AISM**) is set to '1', the Interrupt Status register (**LOSI**, **DFI** and **AISI**) is enabled respectively. Whenever there is a transition ('0' to '1' or '1' to '0') in the corresponding status register, the Interrupt Status register will change into '1', which means an interrupt occurs, and there will be a high to low transition on $\overline{\text{INT}}$ pin. An external pull-up resistor of approximately 10 k Ω is required to support the wire-OR operation of $\overline{\text{INT}}$. When any of the three Interrupt Mask registers is set to '0' (the power-on default value is '0'), the corresponding Interrupt Status register is disabled and the transition on status register is ignored.

2.19.3 INTERRUPT CLEARING

When an interrupt occurs, the Interrupt Status registers: **LOSI**, **DFI** and **AISI**, are read to identify the interrupt source. These registers will be cleared to '0' after the corresponding status registers: **LOS**, **DF** and **AIS** are read. The Status registers will be cleared once the corresponding conditions are met.

Pin $\overline{\text{INT}}$ is pulled high when there is no pending interrupt left. The interrupt handling in the interrupt service routine is showed in [Figure-20](#).