



Chipsmall Limited consists of a professional team with an average of over 10 year of expertise in the distribution of electronic components. Based in Hongkong, we have already established firm and mutual-benefit business relationships with customers from,Europe,America and south Asia,supplying obsolete and hard-to-find components to meet their specific needs.

With the principle of “Quality Parts,Customers Priority,Honest Operation,and Considerate Service”,our business mainly focus on the distribution of electronic components. Line cards we deal with include Microchip,ALPS,ROHM,Xilinx,Pulse,ON,Everlight and Freescale. Main products comprise IC,Modules,Potentiometer,IC Socket,Relay,Connector.Our parts cover such applications as commercial,industrial, and automotives areas.

We are looking forward to setting up business relationship with you and hope to provide you with the best service and solution. Let us make a better world for our industry!



Contact us

Tel: +86-755-8981 8866 Fax: +86-755-8427 6832

Email & Skype: info@chipsmall.com Web: www.chipsmall.com

Address: A1208, Overseas Decoration Building, #122 Zhenhua RD., Futian, Shenzhen, China





LOW SKEW, 1-TO-16, LVCMOS/LVTTL FANOUT BUFFER W/1.2V LVCMOS OUTPUTS

ICS8316

GENERAL DESCRIPTION

The ICS8316 is a low skew, 1-to-16 LVCMOS/LVTTL Fanout Buffer with 1.2V LVCMOS Outputs and a member of the HiPerClockS™ family of High Performance Clock Solutions from IDT. The ICS8316 single ended clock input accepts LVCMOS or LVTTL input levels. The low impedance LVCMOS outputs are designed to drive 50Ω series or parallel terminated transmission lines.

Guaranteed output and part-to-part skew characteristics along with the 1.2V output makes the ICS8316 ideal for high performance, single ended applications that also require a limited output voltage.

FEATURES

- Sixteen 1.2V LVCMOS / LVTTL outputs
- LVCMOS / LVTTL clock input
- Maximum output frequency: 150MHz
- Output skew: 380ps (maximum)
- Propagation delay: 4.6ns (maximum)
- 3.3V core/1.2V output operating supply mode
- 0°C to 70°C ambient operating temperature
- Industrial temperature information available upon request

BLOCK DIAGRAM

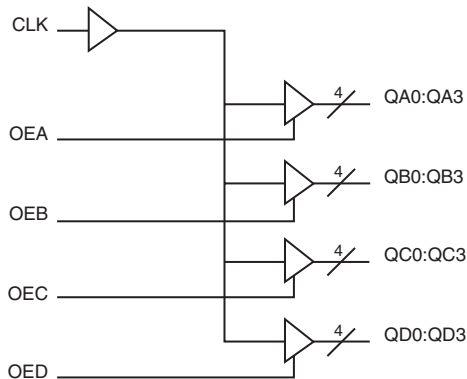

PIN ASSIGNMENT

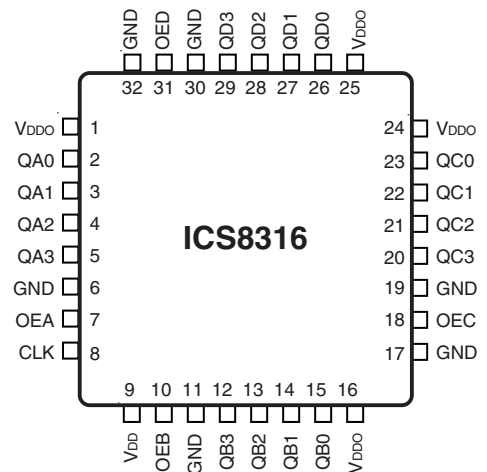

32-Lead VFQFN
5mm x 5mm x 0.925 package body
K Package
Top View

TABLE 1. PIN DESCRIPTIONS

Number	Name	Type		Description
1, 16, 24, 25	V _{DDO}	Power		Output supply pins.
2, 3, 4, 5	QA0, QA1, QA2, QA3	Output		Bank A clock outputs. LVCMOS / LVTTTL interface levels.
6, 11, 17, 19, 30, 32	GND	Power		Power supply ground.
7	OEA	Input	Pullup	Bank A output enable pin. Controls enabling and disabling of QA0:QA3 outputs. LVCMOS / LVTTTL interface levels.
8	CLK	Input	Pulldown	Clock input. LVCMOS / LVTTTL interface levels.
9	V _{DD}	Power		Power supply pin.
10	OEB	Input	Pullup	Bank B output enable pin. Controls enabling and disabling of QB0:QB3 outputs. LVCMOS / LVTTTL interface levels.
12, 13, 14, 15	QB3, QB2, QB1, QB0	Output		Bank B clock outputs. LVCMOS / LVTTTL interface levels.
18	OEC	Input	Pullup	Bank C output enable pin. Controls enabling and disabling of QC0:QC3 outputs. LVCMOS / LVTTTL interface levels.
20, 21, 22, 23	QC3, QC2, QC1, QC0	Output		Bank C clock outputs. LVCMOS / LVTTTL interface levels.
26, 27, 28, 29	QD0, QD1, QD2, QD3	Output		Bank D clock outputs. LVCMOS / LVTTTL interface levels.
31	OED	Input	Pullup	Bank D output enable pin. Controls enabling and disabling of QD0:QD3 outputs. LVCMOS / LVTTTL interface levels.

NOTE: *Pullup* and *Pulldown* refer to internal input resistors. See Table 2, Pin Characteristics, for typical values.

TABLE 2. PIN CHARACTERISTICS

Symbol	Parameter	Test Conditions	Minimum	Typical	Maximum	Units
C _{IN}	Input Capacitance			4		pF
C _{PD}	Power Dissipation Capacitance (per output)	V _{DDO} = 1.26V			15	pF
R _{PULLUP}	Input Pullup Resistor			51		kΩ
R _{PULLDOWN}	Input Pulldown Resistor			51		kΩ
R _{OUT}	Output Impedance	V _{DDO} = 1.2 ± 5%	8	13	21	Ω

TABLE 3A. OUTPUT ENABLE AND CLOCK ENABLE FUNCTION TABLE

Control Inputs	Outputs
OE[A:D]	Qx0:Qx3
0	Hi-Z
1	Active

TABLE 3B. CLOCK INPUT FUNCTION TABLE

Inputs		Outputs
OE[A:D]	CLK	Qx0:Qx3
1	0	LOW
1	1	HIGH

ABSOLUTE MAXIMUM RATINGS

Supply Voltage, V_{DD}	4.6V
Inputs, V_I	-0.5V to $V_{DD} + 0.5V$
Outputs, V_O	-0.5V to $V_{DDO} + 0.5V$
Package Thermal Impedance, θ_{JA}	34.8°C/W (0 lfpm)
Storage Temperature, T_{STG}	-65°C to 150°C

NOTE: Stresses beyond those listed under Absolute Maximum Ratings may cause permanent damage to the device. These ratings are stress specifications only. Functional operation of product at these conditions or any conditions beyond those listed in the *DC Characteristics* or *AC Characteristics* is not implied. Exposure to absolute maximum rating conditions for extended periods may affect product reliability.

TABLE 4A. POWER SUPPLY DC CHARACTERISTICS, $V_{DD} = 3.3V$, $V_{DDO} = 1.2V \pm 5\%$, $T_A = 0^\circ C$ TO $70^\circ C$

Symbol	Parameter	Test Conditions	Minimum	Typical	Maximum	Units
V_{DD}	Power Supply Voltage		3.135	3.3	3.465	V
V_{DDO}	Output Supply Voltage		1.14	1.2	1.26	V
I_{DD}	Power Supply Current				10	μA
I_{DDO}	Output Supply Current				10	μA

TABLE 4B. LVCMOS DC CHARACTERISTICS, $T_A = 0^\circ C$ TO $70^\circ C$

Symbol	Parameter	Test Conditions	Minimum	Typical	Maximum	Units
V_{IH}	Input High Voltage		2		$V_{DD} + 0.3$	V
V_{IL}	Input Low Voltage		-0.3		0.8	V
I_{IH}	Input High Current	CLK	$V_{DD} = V_{IN} = 3.465V$		150	μA
		OEA:OED	$V_{DD} = V_{IN} = 3.465V$		5	μA
I_{IL}	Input Low Current	CLK	$V_{DD} = 3.465V$, $V_{IN} = 0V$	-5		μA
		OEA:OED	$V_{DD} = 3.465V$, $V_{IN} = 0V$	-150		μA
V_{OH}	Output High Voltage	$V_{DDO} = 1.2V \pm 5\%$; NOTE 1	$V_{DDO} * 0.7$			V
V_{OL}	Output Low Voltage	$V_{DDO} = 1.2V \pm 5\%$; NOTE 1			$V_{DDO} * 0.3$	V

NOTE 1: Outputs terminated with 50Ω to $V_{DDO}/2$. See Parameter Measurement section, "Load Test Circuit" diagram.

TABLE 5. AC CHARACTERISTICS, $V_{DD} = 3.3V \pm 5\%$, $V_{DDO} = 1.2V \pm 5\%$, $T_A = 0^\circ C$ TO $70^\circ C$

Symbol	Parameter	Test Conditions	Minimum	Typical	Maximum	Units
f_{MAX}	Output Frequency				150	MHz
tp_{LH}	Propagation Delay Low to High; NOTE 1		2.3	3.45	4.6	ns
$tsk(o)$	Output Skew; NOTE 2, 3				380	ps
$tsk(b)$	Bank Skew; NOTE 3, 4				70	ps
$tsk(pp)$	Part-to-Part Skew; NOTE 3, 5				1.2	ns
t_r/t_f	Output Rise Time	20% to 80%	350		850	ps
odc	Output Duty Cycle	$F_{out} \leq 100MHz$	47		53	%

All parameters measured at f_{MAX} unless noted otherwise.

NOTE 1: Measured from $V_{DD}/2$ of the input to $V_{DDO}/2$ of the output.

NOTE 2: Defined as skew between outputs at the same supply voltage and with equal load conditions. Measured at $V_{DDO}/2$.

NOTE 3: This parameter is defined in accordance with JEDEC Standard 65.

NOTE 4: Defined as skew within a bank of outputs at the same voltages and with equal load conditions.

NOTE 5: Defined as the skew between outputs on different devices operating at the same supply voltages and with equal load conditions. Using the same type of inputs on each device, the outputs are measured at $V_{DDO}/2$.

PARAMETER MEASUREMENT INFORMATION

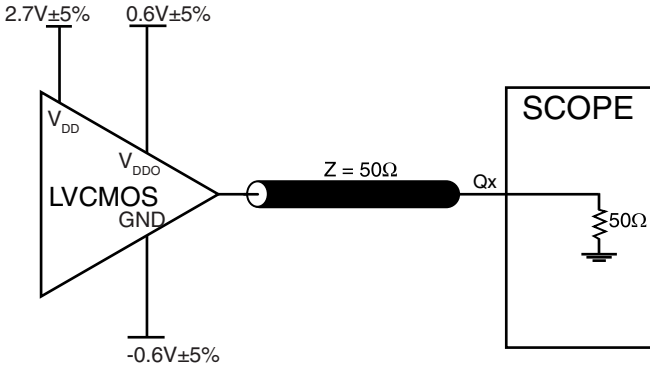

3.3V CORE/1.2V OUTPUT LOAD AC TEST CIRCUIT

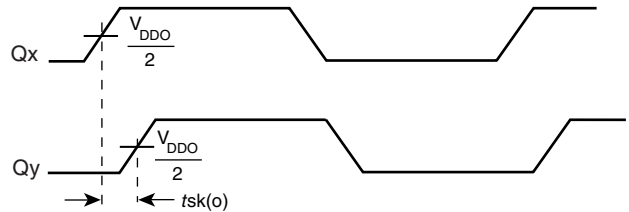

OUTPUT SKEW

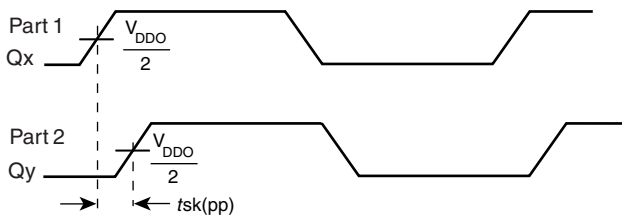

PART-TO-PART SKEW

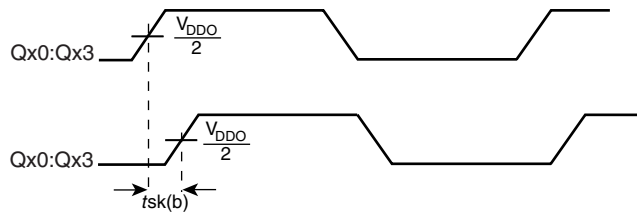

BANK SKEW (where x denotes outputs in the same bank)

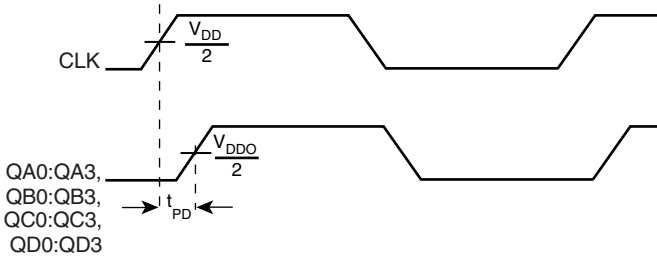

PROPAGATION DELAY

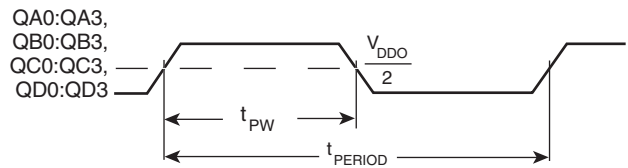

$$\text{odc} = \frac{t_{PW}}{t_{PERIOD}} \times 100\%$$

OUTPUT DUTY CYCLE/PLUSE WIDTH/PERIOD

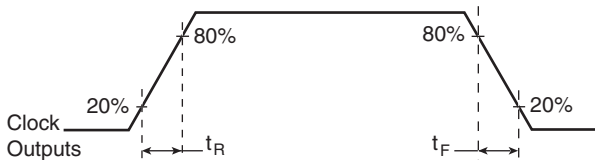

OUTPUT RISE/FALL TIME

APPLICATION INFORMATION

RECOMMENDATIONS FOR UNUSED INPUT AND OUTPUT PINS

INPUTS:

LVC MOS CONTROL PINS

All control pins have internal pull-ups or pull-downs; additional resistance is not required but can be added for additional protection. A 1k Ω resistor can be used.

OUTPUTS:

LVC MOS OUTPUTS

All unused LVC MOS output can be left floating. We recommend that there is no trace attached.

VFQFN EPAD THERMAL RELEASE PATH

In order to maximize both the removal of heat from the package and the electrical performance, a land pattern must be incorporated on the Printed Circuit Board (PCB) within the footprint of the package corresponding to the exposed metal pad or exposed heat slug on the package, as shown in *Figure 1*. The solderable area on the PCB, as defined by the solder mask, should be at least the same size/shape as the exposed pad/slug area on the package to maximize the thermal/electrical performance. Sufficient clearance should be designed on the PCB between the outer edges of the land pattern and the inner edges of pad pattern for the leads to avoid any shorts.

While the land pattern on the PCB provides a means of heat transfer and electrical grounding from the package to the board through a solder joint, thermal vias are necessary to effectively conduct from the surface of the PCB to the ground plane(s). The land pattern must be connected to ground through these vias. The vias act as "heat pipes". The number of vias (i.e. "heat pipes")

are application specific and dependent upon the package power dissipation as well as electrical conductivity requirements. Thus, thermal and electrical analysis and/or testing are recommended to determine the minimum number needed. Maximum thermal and electrical performance is achieved when an array of vias is incorporated in the land pattern. It is recommended to use as many vias connected to ground as possible. It is also recommended that the via diameter should be 12 to 13mils (0.30 to 0.33mm) with 1oz copper via barrel plating. This is desirable to avoid any solder wicking inside the via during the soldering process which may result in voids in solder between the exposed pad/slug and the thermal land. Precautions should be taken to eliminate any solder voids between the exposed heat slug and the land pattern. Note: These recommendations are to be used as a guideline only. For further information, refer to the Application Note on the *Surface Mount Assembly* of Amkor's Thermally/Electrically Enhance Leadframe Base Package, Amkor Technology.

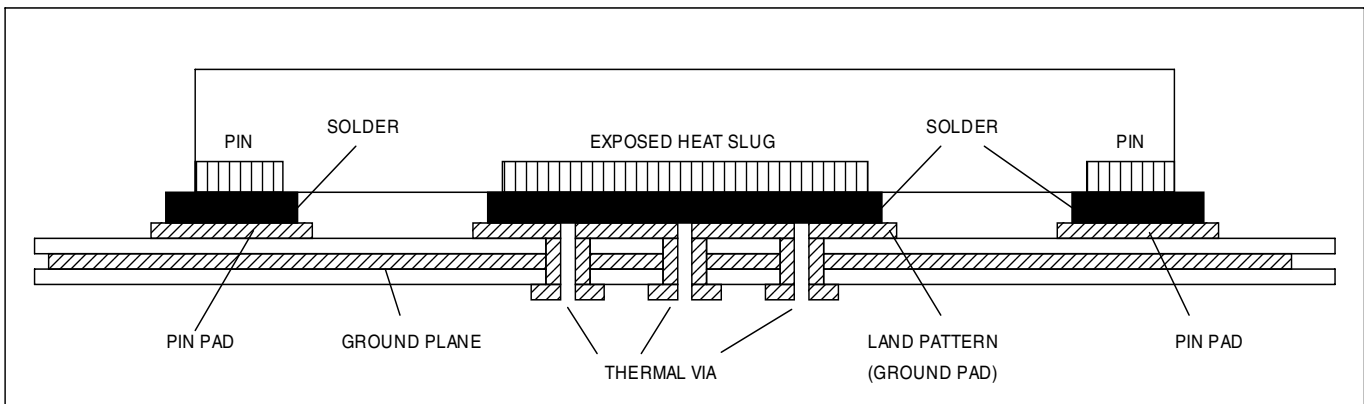

FIGURE 1. P.C. ASSEMBLY FOR EXPOSED PAD THERMAL RELEASE PATH -SIDE VIEW (DRAWING NOT TO SCALE)

RELIABILITY INFORMATION

TABLE 6. θ_{JA} vs. AIR FLOW TABLE FOR 32 LEAD VFQFN

θ_{JA} vs. 0 Air Flow (Linear Feet per Minute)	
Multi-Layer PCB, JEDEC Standard Test Boards	0 34.8°C/W

TRANSISTOR COUNT

The transistor count for ICS8316 is: 416

PACKAGE OUTLINE AND DIMENSIONS - K SUFFIX FOR 32 LEAD VFQFN

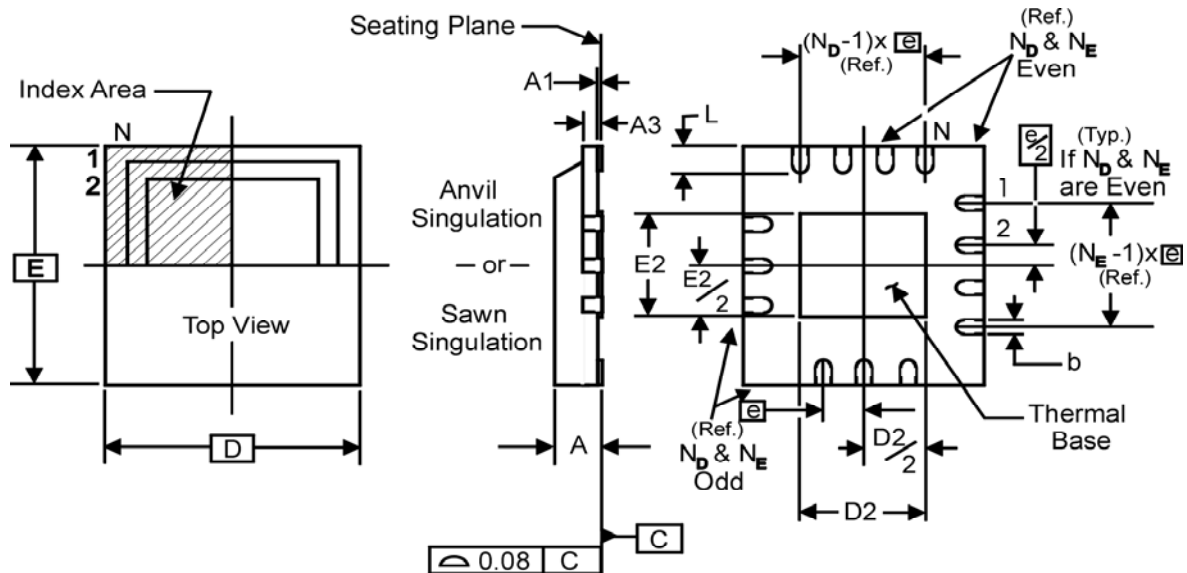

NOTE: The following package mechanical drawing is a generic drawing that applies to any pin count VFQFN package. This drawing is not intended to convey the actual pin count or pin layout of

this device. The pin count and pinout are shown on the front page. The package dimensions are in Table 11 below.

TABLE 7. PACKAGE DIMENSIONS

JEDEC VARIATION ALL DIMENSIONS IN MILLIMETERS			
SYMBOL	VHHD-2		
	MINIMUM	NOMINAL	MAXIMUM
N	32		
A	0.80	--	1.00
A1	0	--	0.05
A3	0.25 Ref.		
b	0.18	0.25	0.30
N_D	8		
N_E	8		
D	5.00 BASIC		
D2	3.0		3.3
E	5.00 BASIC		
E2	3.0		3.3
e	0.50 BASIC		
L	0.30	0.40	0.50

Reference Document: JEDEC Publication 95, MO-220

TABLE 8. ORDERING INFORMATION

Part/Order Number	Marking	Package	Shipping Packaging	Temperature
ICS8316AKLF	ICS8316AKLF	32 Lead "Lead-Free" VFQFN	tray	0°C to 70°C
ICS8316AKLFT	ICS8316AKLF	32 Lead "Lead-Free" VFQFN	2500 tape & reel	0°C to 70°C

NOTE: Parts that are ordered with an "LF" suffix to the part number are the Pb-Free configuration and are RoHS compliant.

While the information presented herein has been checked for both accuracy and reliability, Integrated Device Technology, Incorporated (IDT) assumes no responsibility for either its use or for infringement of any patents or other rights of third parties, which would result from its use. No other circuits, patents, or licenses are implied. This product is intended for use in normal commercial and industrial applications. Any other applications such as those requiring high reliability or other extraordinary environmental requirements are not recommended without additional processing by IDT. IDT reserves the right to change any circuitry or specifications without notice. IDT does not authorize or warrant any IDT product for use in life support devices or critical medical instruments.

REVISION HISTORY SHEET

Rev	Table	Page	Description of Change	Date
B	T5	1	Features section - updated Output Skew bullet.	2/29/08
		3	AC Characteristics Table - per PCN changed Output Skew parameter from 140ps max. to 380ps max. And changed Bank Skew from 60ps max. to 70ps max.	
	5	Added VFQFN Thermal Release Path section.		
	7	Added note to Package Outline.		
	T7	7	Package Dimensions Table - corrected D2/E2 measurements.	

Innovate with IDT and accelerate your future networks. Contact:

www.IDT.com

For Sales

800-345-7015
408-284-8200
Fax: 408-284-2775

For Tech Support

netcom@idt.com
480-763-2056

Corporate Headquarters

Integrated Device Technology, Inc.
6024 Silver Creek Valley Road
San Jose, CA 95138
United States
800 345 7015
+408 284 8200 (outside U.S.)

Japan

NIPPON IDT KK
Sanbancho Tokyu Bld. 7F,
8-1 Sanbancho
Chiyoda-ku, Tokyo 102-0075
+81 3 3221 9822
+81 3 3221 9824 (fax)

Asia

Integrated Device Technology
IDT (S) Pte. Ltd.
1 Kallang Sector, #07-01/06
Kolam Ayer Industrial Park
Singapore 349276
+65 6 744 3356
+65 6 744 1764 (fax)

Europe

IDT Europe, Limited
321 Kingston Road
Leatherhead, Surrey
KT22 7TU
England
+44 (0) 1372 363 339
+44 (0) 1372 378851 (fax)

