



Chipsmall Limited consists of a professional team with an average of over 10 year of expertise in the distribution of electronic components. Based in Hongkong, we have already established firm and mutual-benefit business relationships with customers from,Europe,America and south Asia,supplying obsolete and hard-to-find components to meet their specific needs.

With the principle of “Quality Parts,Customers Priority,Honest Operation,and Considerate Service”,our business mainly focus on the distribution of electronic components. Line cards we deal with include Microchip,ALPS,ROHM,Xilinx,Pulse,ON,Everlight and Freescale. Main products comprise IC,Modules,Potentiometer,IC Socket,Relay,Connector.Our parts cover such applications as commercial,industrial, and automotives areas.

We are looking forward to setting up business relationship with you and hope to provide you with the best service and solution. Let us make a better world for our industry!



## Contact us

Tel: +86-755-8981 8866 Fax: +86-755-8427 6832

Email & Skype: info@chipsmall.com Web: www.chipsmall.com

Address: A1208, Overseas Decoration Building, #122 Zhenhua RD., Futian, Shenzhen, China



**PROPER USE GUIDELINES**

Cumulative Trauma Disorders can result from the prolonged use of manually powered hand tools. Hand tools are intended for occasional use and low volume applications. A wide selection of powered application equipment for extended-use, production operations is available.

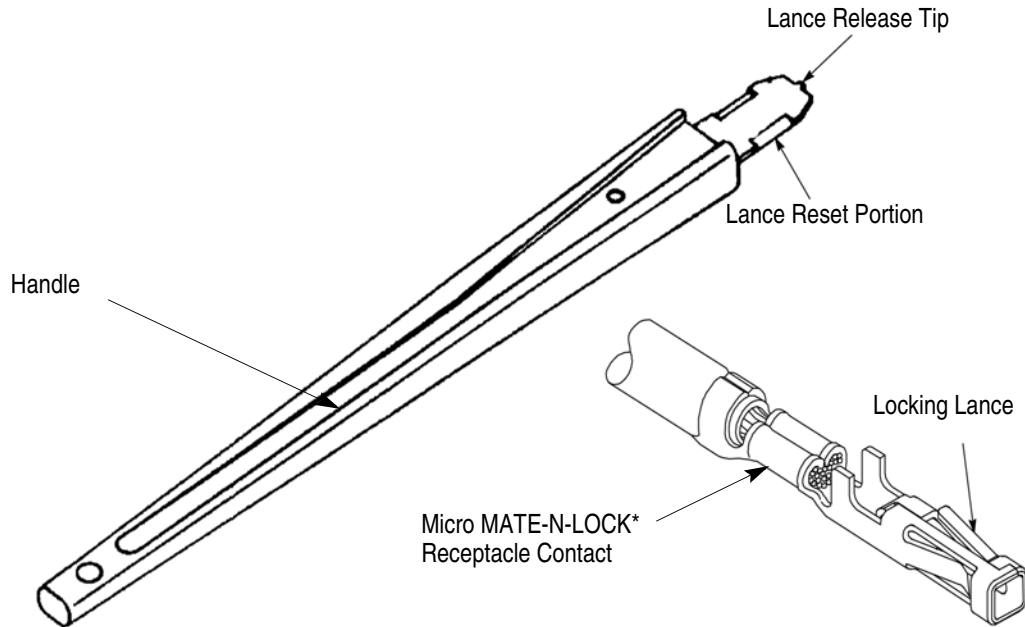

Figure 1

**1. INTRODUCTION**

Extraction/Lance Reset Tool 843996-6 is designed to remove Micro MATE-N-LOK receptacle contacts from a housing and reset overly depressed contact locking lances. See Figure 1.

Read these instructions thoroughly before attempting to remove any contacts or resetting the locking lance.

**NOTE** *All dimensions are in millimeters (followed by inches in brackets). Figures and illustrations are for reference only, and are not drawn to scale.*

Reasons for reissue of this instruction sheet are provided in Section 5, REVISION SUMMARY.

**2. DESCRIPTION**

The tool features a handle marked with the part number, a contact lance release tip, locking lance reset portion, and tool stop. The contact lance release tip is designed to depress the contact locking lance to allow extraction of the contact. The tool stop prevents over-insertion of the tip. The lance reset portion is designed to reposition an overly depressed locking lance to the proper height assuring retention of the contact in the housing.

**3. USING THE TOOL** (See Figure 2)

**3.1. Extraction**

1. While holding the housing, grasp the wire at the back of the housing, and push forward toward the mating end of the housing to disengage the contact locking lance from the shoulder of the circuit cavity.
2. Fully insert the extraction tool tip into the window adjacent to the circuit cavity until it bottoms inside the window.
3. Pull back lightly on the wire and, if necessary, move the tool just enough to release the contact locking lance.
4. Pull the contact from the housing, then remove the tool.



**3.2. Locking Lance Reset** (See Figure 3)

Check compatibility of the contact and tool, then proceed as follows:

1. Orient the lance reset portion so that the taper is facing the contact locking lance.

3. Remove the tool. The contact is ready for re-insertion into the housing.s.

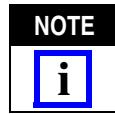

*Damaged contacts should not be used. If a damaged contact is evident, it should be cut from the wire and replaced with a new one.*

**Extraction**

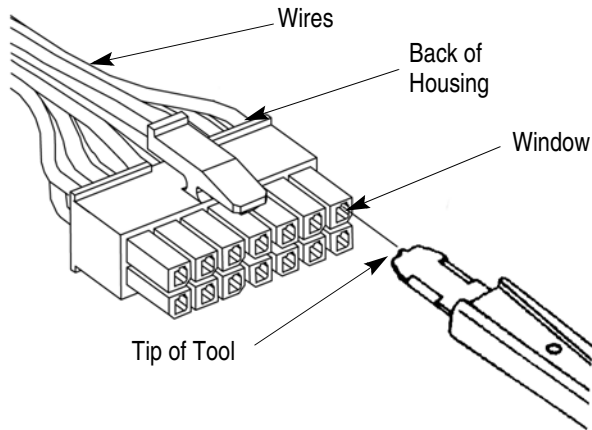

Figure 2

**4. MAINTENANCE AND INSPECTION**

The tool should conform to the dimensions provided in Figure . It is recommended that each tool be inspected upon arrival to be sure it has not been damaged in transit and at regularly scheduled intervals to be sure it remains functional.

Keep the tool clean.

**5. REVISION SUMMMARUY**

Since the previous release of this instruction sheet, the new company logo has been applied

**Reset Locking Lance**

Side View

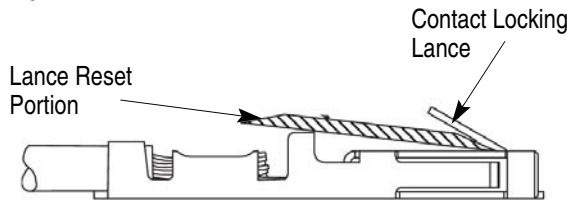

Top View

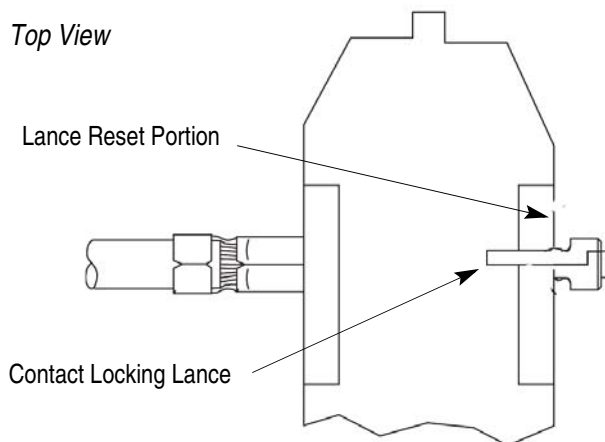

Figure 3

2. Keep the lance reset portion against the contact and slide it towards the base of the contact locking lance until it bottom

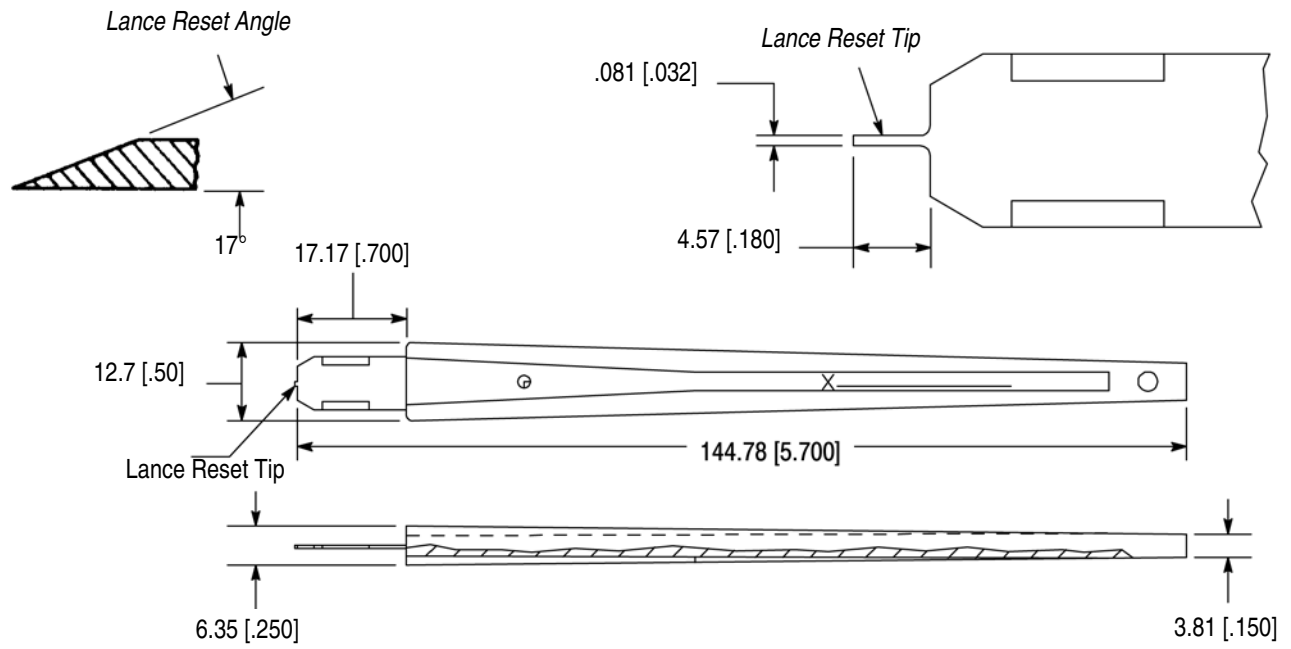

Figure 4