



Chipsmall Limited consists of a professional team with an average of over 10 year of expertise in the distribution of electronic components. Based in Hongkong, we have already established firm and mutual-benefit business relationships with customers from,Europe,America and south Asia,supplying obsolete and hard-to-find components to meet their specific needs.

With the principle of “Quality Parts,Customers Priority,Honest Operation,and Considerate Service”,our business mainly focus on the distribution of electronic components. Line cards we deal with include Microchip,ALPS,ROHM,Xilinx,Pulse,ON,Everlight and Freescale. Main products comprise IC,Modules,Potentiometer,IC Socket,Relay,Connector.Our parts cover such applications as commercial,industrial, and automotives areas.

We are looking forward to setting up business relationship with you and hope to provide you with the best service and solution. Let us make a better world for our industry!



## Contact us

Tel: +86-755-8981 8866 Fax: +86-755-8427 6832

Email & Skype: info@chipsmall.com Web: www.chipsmall.com

Address: A1208, Overseas Decoration Building, #122 Zhenhua RD., Futian, Shenzhen, China



# **HAKKO 851**

**SMD REWORK STATION**

SMD REWORK SYSTEM

No.851-2

## **Instruction Manual**

Thank you for purchasing the Hakko 851 SMD REWORK STATION.

This Manual describes the use and maintenance of the Hakko 851. Please read it before using the unit. After reading the manual, keep it in a safe place for future reference.

### **Table of Contents**

<b>Package Contents/Specifications.....</b>	<b>1</b>
<b>Precautions Before Use.....</b>	<b>2</b>
<b>Part Names &amp; Descriptions .....</b>	<b>3</b>
<b>Using the HAKKO 851 (Preparation) .....</b>	<b>4</b>
<b>Using the HAKKO 851 (Desoldering parts).....</b>	<b>5</b>
<b>Using the HAKKO 851 (Soldering parts) .....</b>	<b>6</b>
<b>Replacing the Heating Element .....</b>	<b>6~8</b>
<b>Parts List (Station) .....</b>	<b>9•10</b>
<b>(Iron).....</b>	<b>11•12</b>
<b>Temperature Distribution Charts.....</b>	<b>13•14</b>

# Package Contents

Station / Iron .....		Nozzle / $\phi$ 1.5mm (0.06in) .....	
Holder Part .....		Nozzle / $\phi$ 3.0mm (0.12in) .....	
Nozzle Holder .....			
Instruction Manual .....			

# Specifications

<b>Name</b>	Hakko 851
<b>Power Consumption</b>	85W

### •Station

<b>Power Consumption</b>	5W
<b>Pump</b>	Diaphragm type
<b>Capacity</b>	6 liters/minute (max.)
<b>Fuse</b>	2A
<b>External Dimensions (W×H×D)</b>	167×101×182mm (6.6×4.0×7.1 in) (not including Handle and Iron)

### •Soldering Iron

<b>Power Consumption</b>	80W
<b>Heating Element</b>	Ceramic heater, 80W
<b>Standard Nozzle Inner dia.</b>	$\phi$ 2.0mm (0.08 in) (No. A1066)
<b>Hot Air Blow Temperature</b>	100-540°C (212 ~ 1004°F)
<b>Length</b>	217 mm (8.5 in) (not including Silicone Hose)

### •Replacement Parts

	No.	Name/Specifications
<b>Heating Element</b>	A1068	Heating Element/120V-80W, Ceramic
<b>Nozzle</b>	A1065	Nozzle/ $\phi$ 1.5mm (0.06 in), Nut included
	A1066	Nozzle/ $\phi$ 2.0mm (0.08 in), Nut included
	A1067	Nozzle/ $\phi$ 3.0mm (0.12 in), Nut included
	A1147	Nozzle/ $\phi$ 1.0mm (0.04 in), Nut included

\* Specifications and appearance are subject to change without notice.

No. A1065

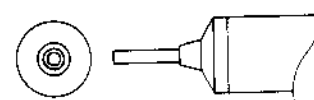

Inner dia: 1.5 mm (0.06 in)

No. A1066

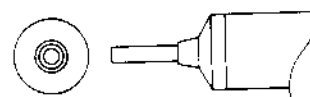

Inner dia: 2.0 mm (0.08 in)

No. A1067

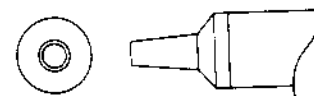

Inner dia: 3.0 mm (0.12 in)

No. A1147

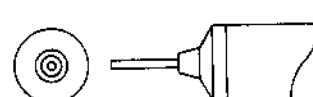

Inner dia: 1.0 mm (0.04 in)

# Precautions Before Use

---

## High Temperature

Do not operate the unit near flammable gases and materials. Also, be careful not to come in contact with the hot air or Nozzle as you may be severely burned.

## Power

If the unit is left for a long period of time with the power on, its service life may be shortened and unexpected accidents may occur.

## Pump

Do not disassemble the pump, as this may result in damage to the unit.

## Shocks

Severe shocks may cause component breakage or a deterioration in performance. Handle the unit carefully. The Heating Element is made of a ceramic material and should be handled with special care. Do not pound the Iron on the workbench or cool it too rapidly.

## Repair

When requesting repairs, bring or send the fully assembled unit (both Iron and Station) to a sales outlet or representative.

# Part Names & Descriptions

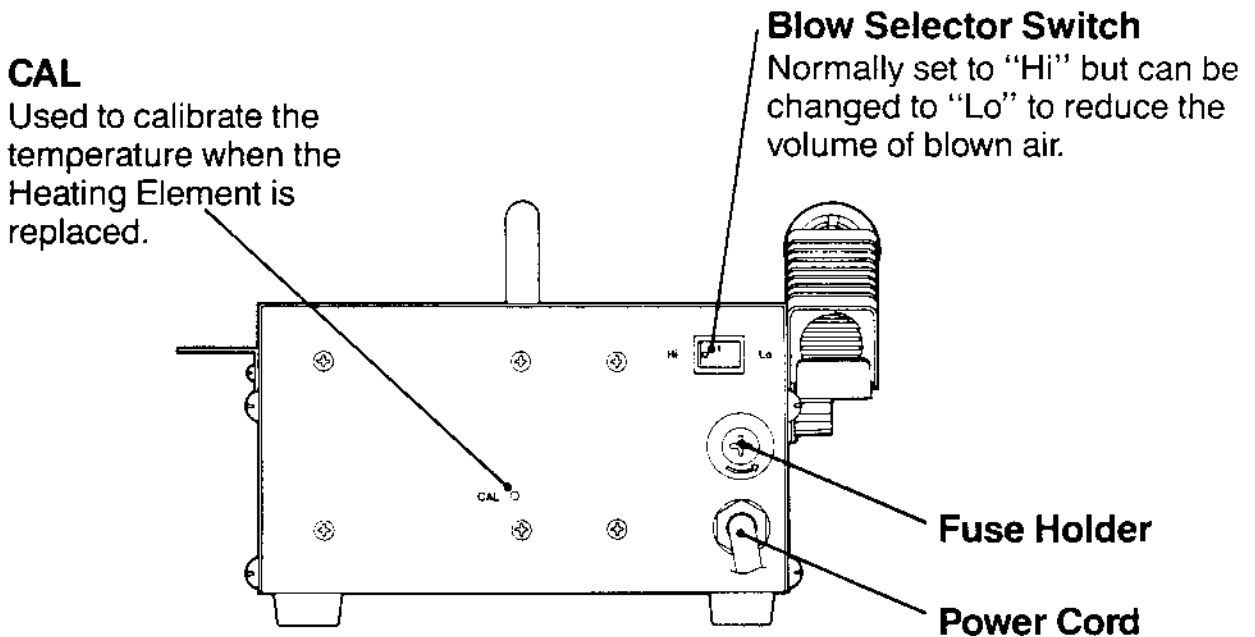
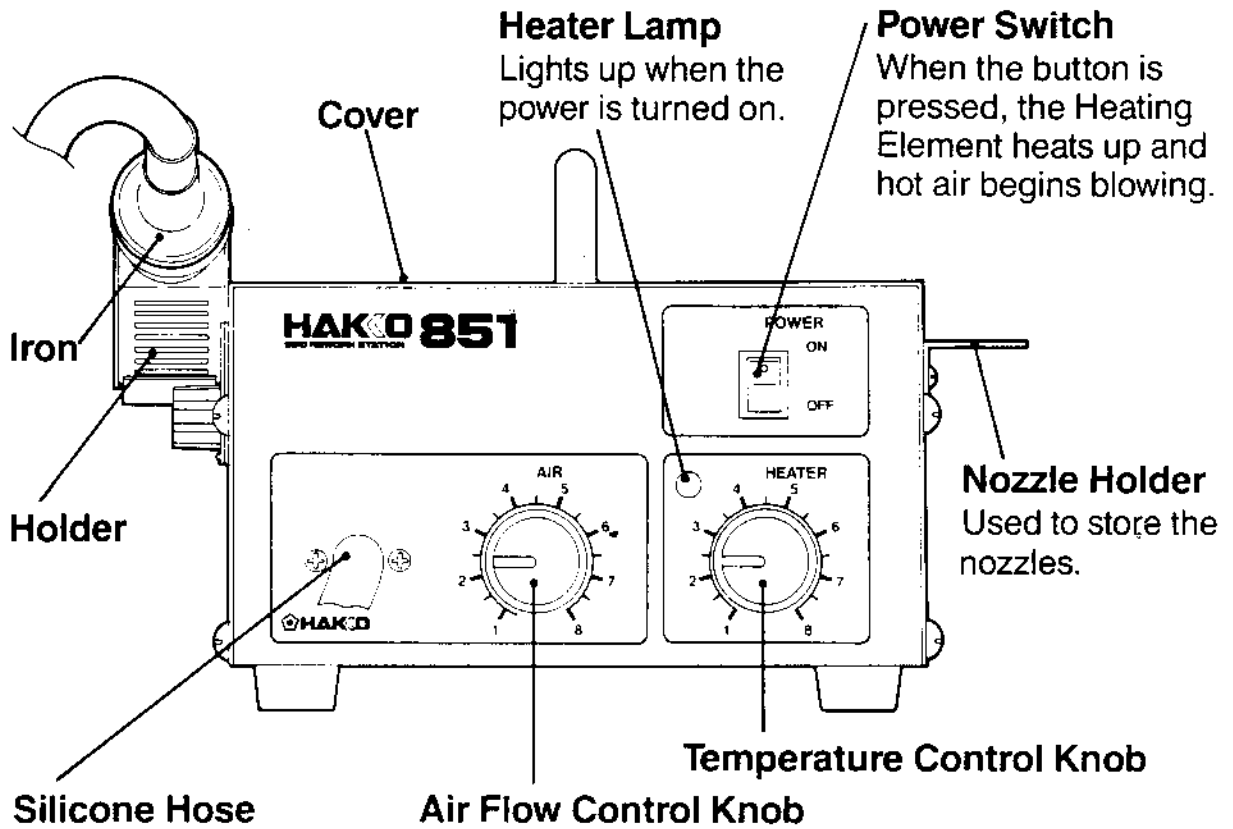

# Using the HAKKO 851 (Preparation)

- ① **Attach the Holder**
- ② **Insert Iron into the Holder**
- ③ **Insert Power Plug into outlet.**
  - Check to make sure the Power Switch is set to the OFF position before inserting the Power Plug.
- ④ **Adjust blow level and temperature**

Refer to the temperature distribution charts (P. 9) and adjust the blow level and temperature using the Air Flow and Temperature Control Knob.
- ⑤ **Turn on power**

When the Power Switch is turned on, the Heater Power Lamp will light up.
- ⑥ **The unit is ready for use approximately two (2) minutes after the power is turned on**

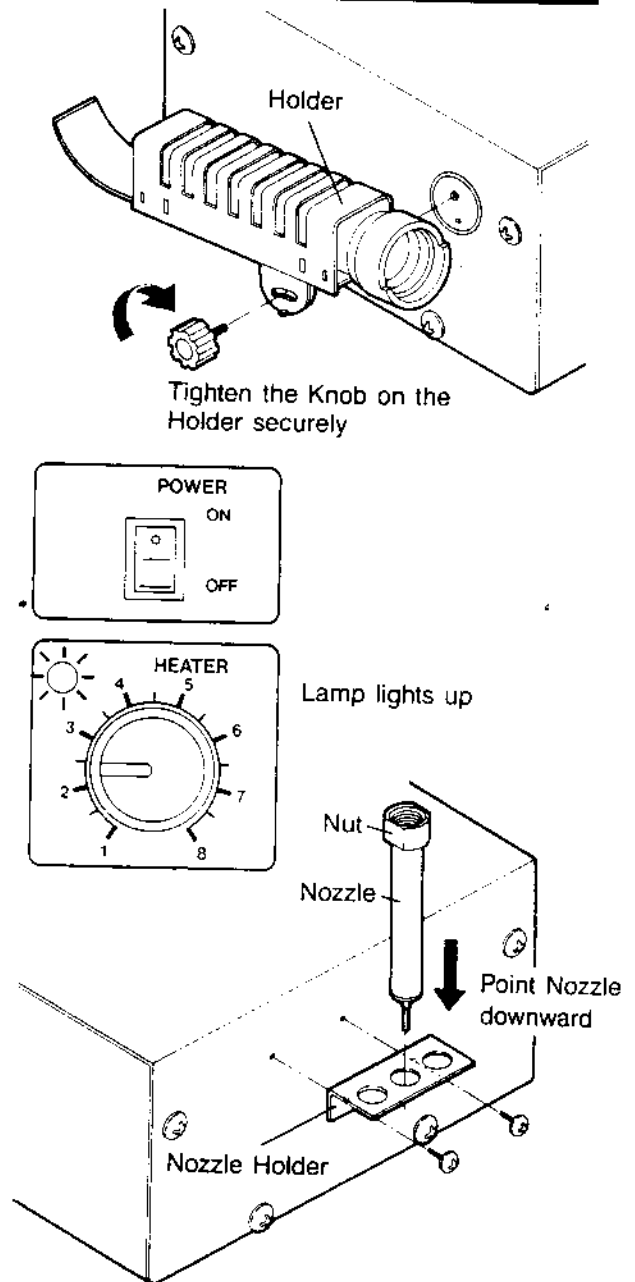

## Attaching and using the Nozzle Holder:

Attach the Nozzle shelf included with the unit. With the Nuts on the Nozzles, insert them into the holes in the Nozzle Holder with the tips facing downward, as shown in the figure above.

# Using the HAKKO 851 (Desoldering parts)

The unit can be used approximately two (2) minutes after the power has been turned on.

## ① Heat the part

Apply the hot air to the part that is to be removed in order to melt the solder.

### ⚠ CAUTION

Be careful not to touch the component, etc. with the tip of the Nozzle.

The Blow Selector Switch on the rear of the unit should normally be set to "Hi". To reduce the blow level, set it to "Lo".

## ② Grasp the part, using tweezers.

While heating the part, use tweezers to grasp the part to be removed.

When grasping the part, do so by straddling the sides that are not soldered. This will help prevent the heat from dissipating.

## ③ Remove the part

When the solder has melted, raise the tweezers to remove the part.

## ④ Remove any remaining solder

After the part has been removed, remove the old solder with desoldering wire or other solder removal tool.

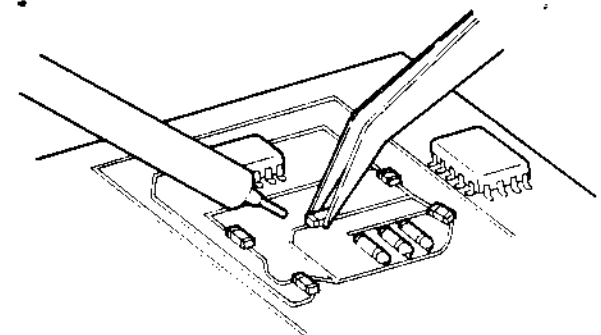
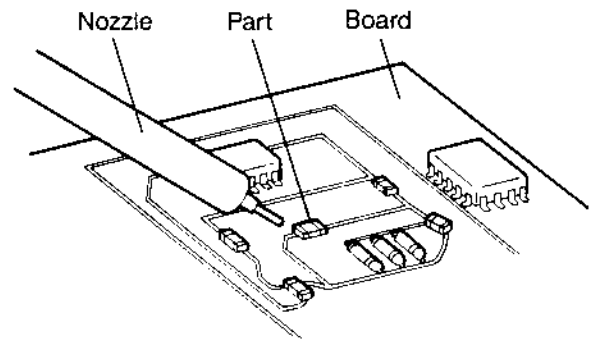

Using tweezers, grasp the unsoldered sides of the part

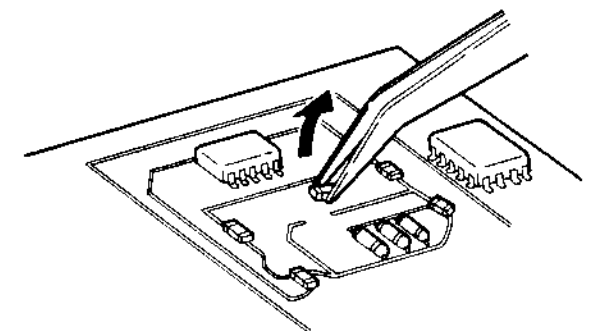

# Using the HAKKO 851 (Soldering parts)

① **Coat with solder paste**  
Coat with a suitable amount of solder paste and mount the part.

② **Preheat the part**

③ **Solder the part**  
Apply the hot air to the section to be soldered and solder it in place.

**⚠ CAUTION**

If the blow level is too great, the part or the solder may be blown out of place. Reduce the blow level when soldering parts.

**⚠ CAUTION**

Soldering using Hot Air has many advantages, but it sometimes results in inadequate soldering. We recommend that all of the conditions for soldering be studied carefully.

## Replacing the Heating Element

① **Disassemble the Air Nozzle**

- Remove the Cover from the unit.
- Loosen the Packing Retainer on the rear of the Panel.

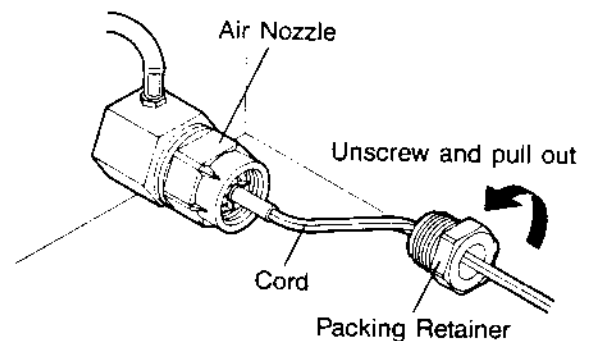



## ② Disassemble the Iron

- Remove the Nut, Nozzle and Nipple in that order.
- Slide the tube off of the Terminal in the direction indicated by the arrow, then detach the Grounding Spring from the sleeve.

## ③ Pull out the Heating Element

- Pull the Silicone Hose so it is straight and then pull out the Heating Element from the Handle, along with each of the Cords.

### ⚠ CAUTION

When the Cords are caught inside the Silicone Hose and do not move freely, press down on it lightly from above.

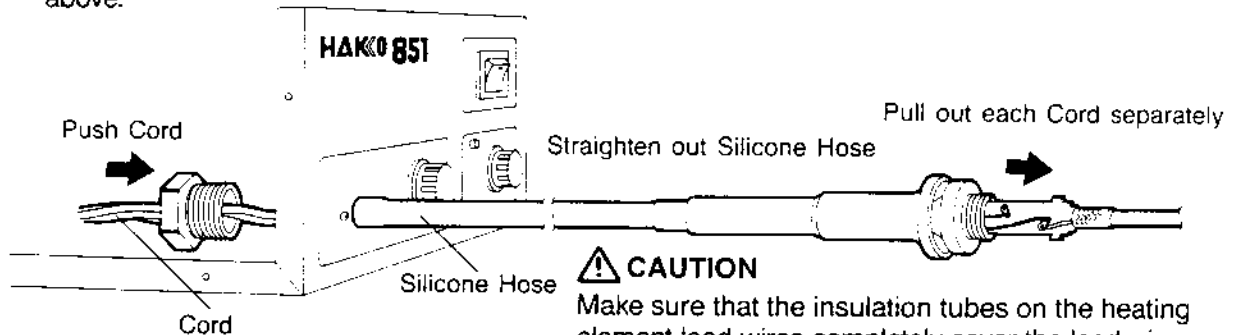
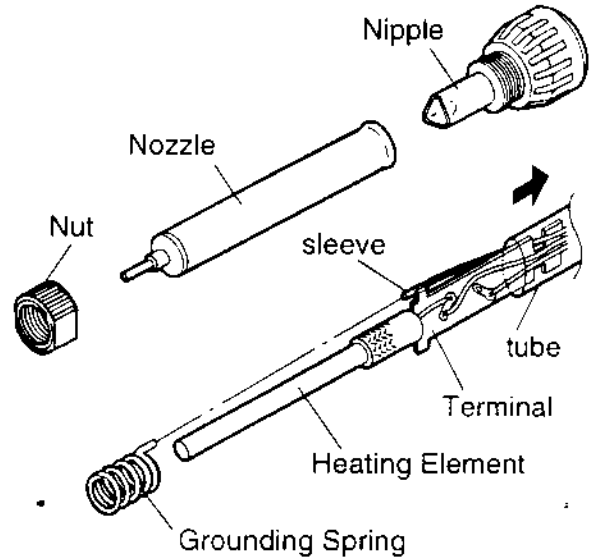

## ④ Replace Heating Element

- Using a stripper or other desoldering tool, remove the solder from the soldered section of the Terminal, then remove the old Heating Element.
- Set the new Heating Element in place as shown in the figures at right.
- Solder the lead wire of the Heating Element to the Terminal.

### ⚠ CAUTION

Make sure that the insulation tubes on the heating element lead wires completely cover the lead wires when the heating element is put into place. If the lead wires are showing this will cause the heating element to protrude too far from the terminal board and block the air flow out of the nozzle.

Confirm that the distance between the tip of the heating element and the terminal is 82~84mm. (3.2in.~3.3in.)

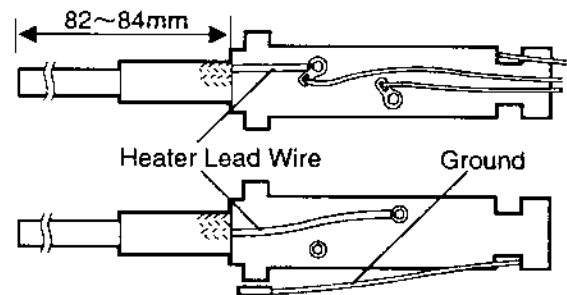

### ⑤ Reassemble the Iron

- Attach the Grounding Spring to the sleeve, then slide the tube back over the Terminal.
- Pull the Cord from the Air Nozzle side to insert the Terminal back in the Handle.
- Attach the Nipple, Nozzle and Nut.

#### ⚠ CAUTION

The Silicone Hose should be straight while this is done. Also, be sure to pull all 3 Cords (2 white, 1 green) together.

### ⑥ Reassemble Air Nozzle

- Push the Packing and Cord Stopper through the Tube and insert in the Air Nozzle.

#### ⚠ CAUTION

Be sure to push the Packing and Cord Stopper through the Tube in order to prevent air leakage.

- Screw on the Packing Retainer.
- Replace the Cover on the unit.

### ⑦ Calibrate the temperature

After replacing the Heating Element, be sure to calibrate the temperature to ensure accurate temperature control.

- Attach  $\varnothing 2.0\text{mm}$  (0.08 in.) Nozzle and set the Blow Selector Switch to Hi. Set the Temperature Control Knob to "8" and the Air Flow Control Knob to "5", then heat the Nozzle for two (2) minutes.
- Using a screwdriver, adjust the CAL control until the temperature of the air 2mm (0.08 in) from the blow exit aperture is  $540^{\circ}\text{C}$  ( $1004^{\circ}\text{F}$ ).

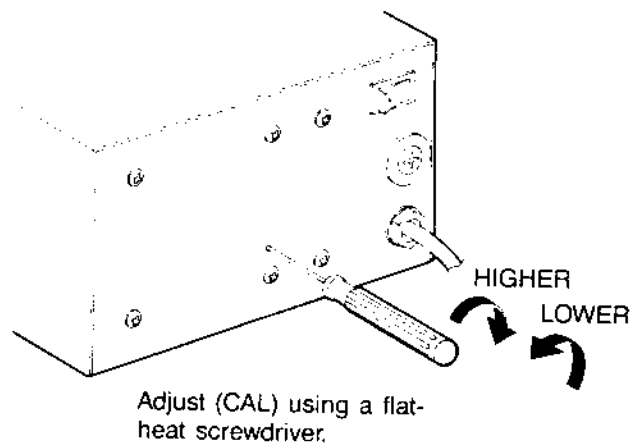
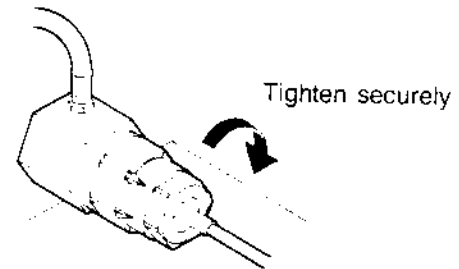
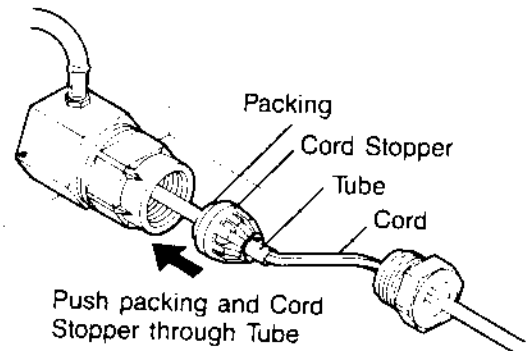

# Parts List (Station)

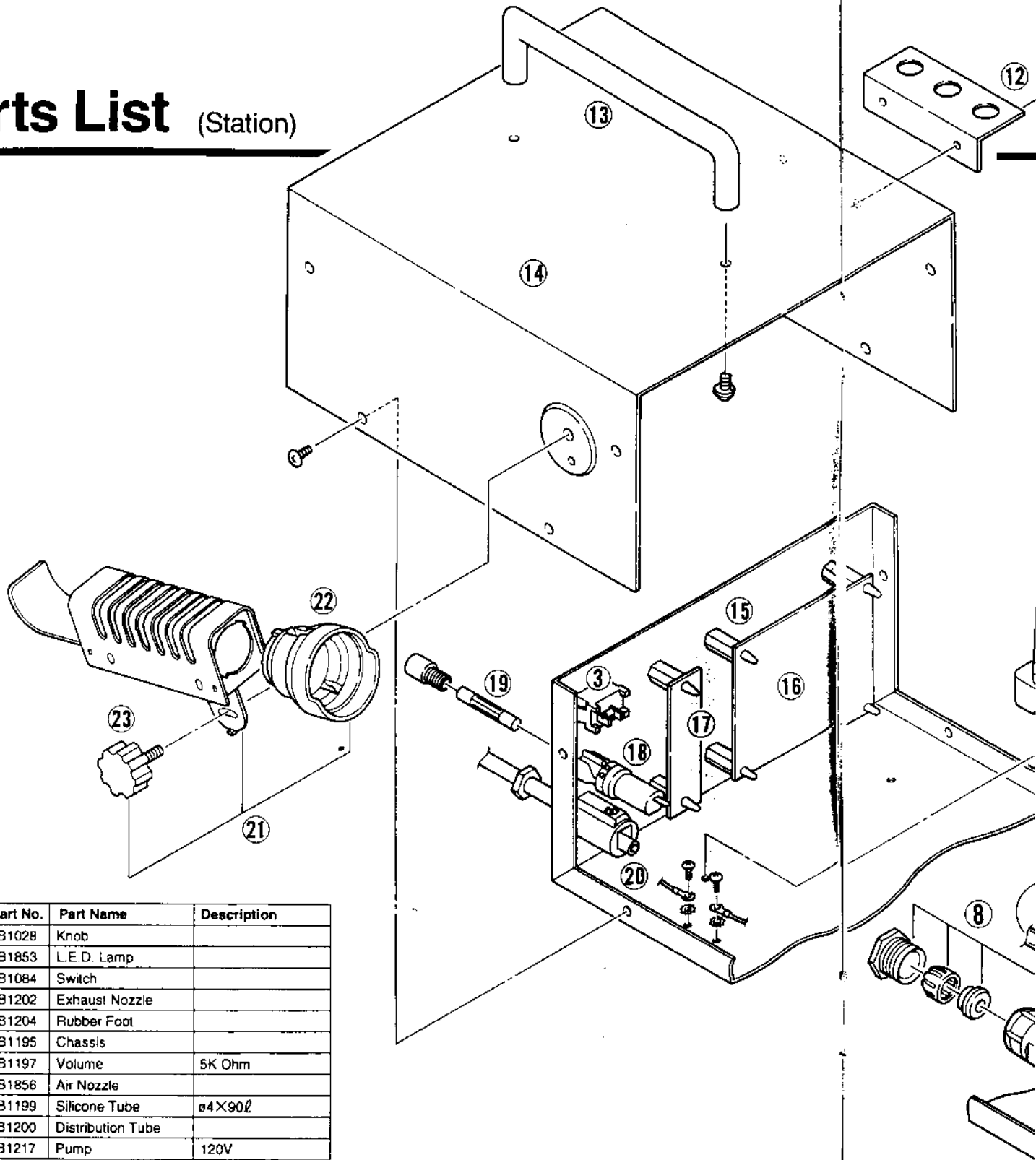

Item No.	Part No.	Part Name	Description
1	B1028	Knob	
2	B1853	L.E.D. Lamp	
3	B1084	Switch	
4	B1202	Exhaust Nozzle	
5	B1204	Rubber Foot	
6	B1195	Chassis	
7	B1197	Volume	5K Ohm
8	B1856	Air Nozzle	
9	B1199	Silicone Tube	ø4×90ℓ
10	B1200	Distribution Tube	
11	B1217	Pump	120V

Item No.	Part No.	Part Name	Description
12	B1212	Nozzle Holder	
13	B1193	Handle	
14	B1194	Cover	
15	B1855	Locking Spacer	
16	B1218	P.W.B.	120V
17	B1207	Wiring Board	
18	B1041	Fuse Holder	w/o Fuse
19	B1042	Fuse	2A
20	B1208	Cord Stopper	
21	B1190	Holder	with Iron Receptacle & Thumb Screw
22	B1191	Iron Receptacle	
23	B1192	Thumb Screw	

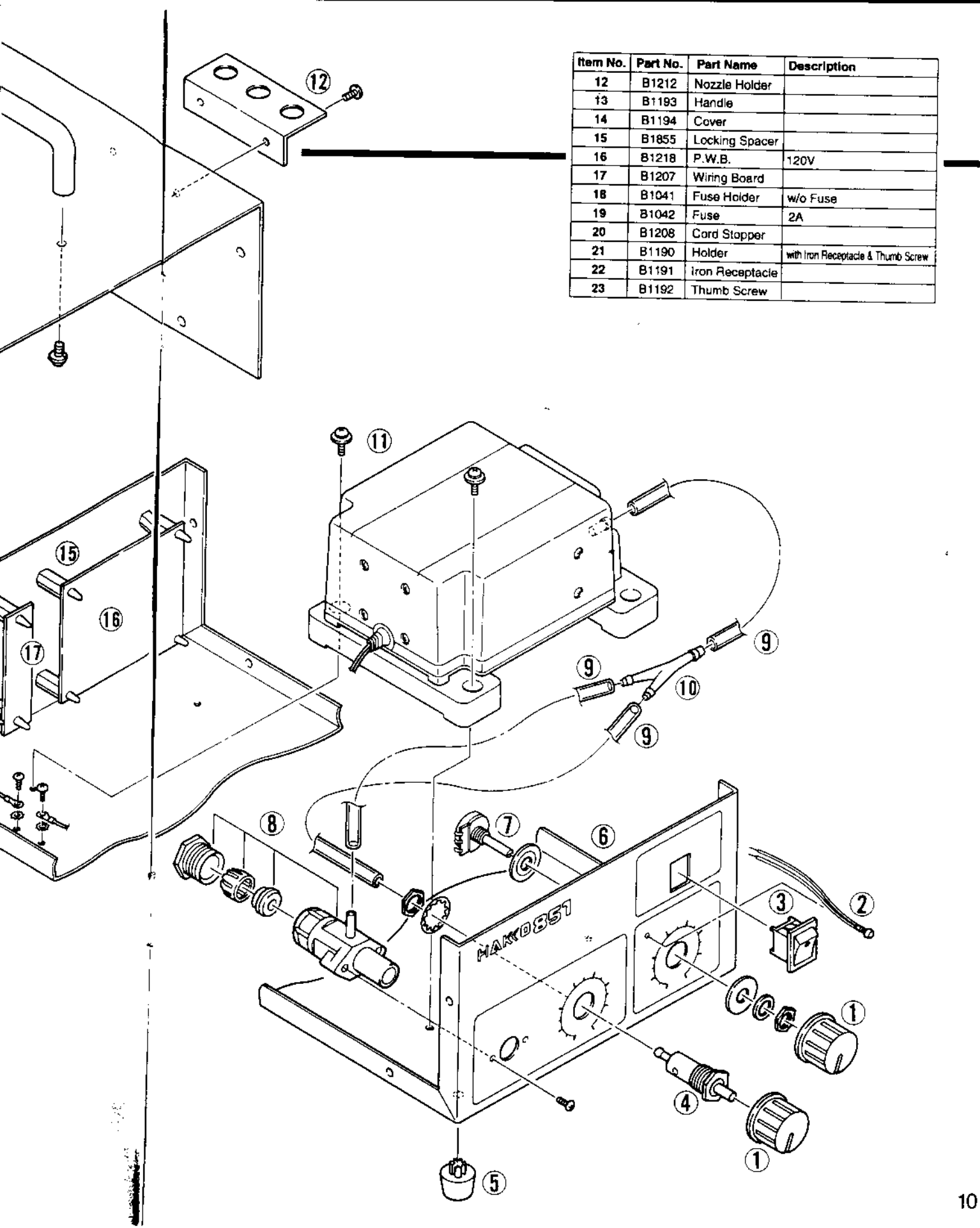

# Parts List (Iron)

Item No.	Part No.	Part Name	Description
1	B1182	Nut	with Stopper
2	A1065	Nozzle	$\phi 1.5\text{mm}(0.06\text{in})$ , with Nut
	A1066	Nozzle	$\phi 2.0\text{mm}(0.08\text{in})$ , with Nut
	A1067	Nozzle	$\phi 3.0\text{mm}(0.12\text{in})$ , with Nut
3	B1183	Nipple	with O-ring(P15)
4	B1213	O-ring (P15)	
5	B1184	Grounding Spring	
6	A1068	Heating Element	120V-80W, Ceramic
7	B1187	Terminal	with Cord Stopper
8	B1189	Cord	
9	B1186	Handle Cover	
10	B1185	Handle	with Handle Cover
11	B1188	Silicone Hose	

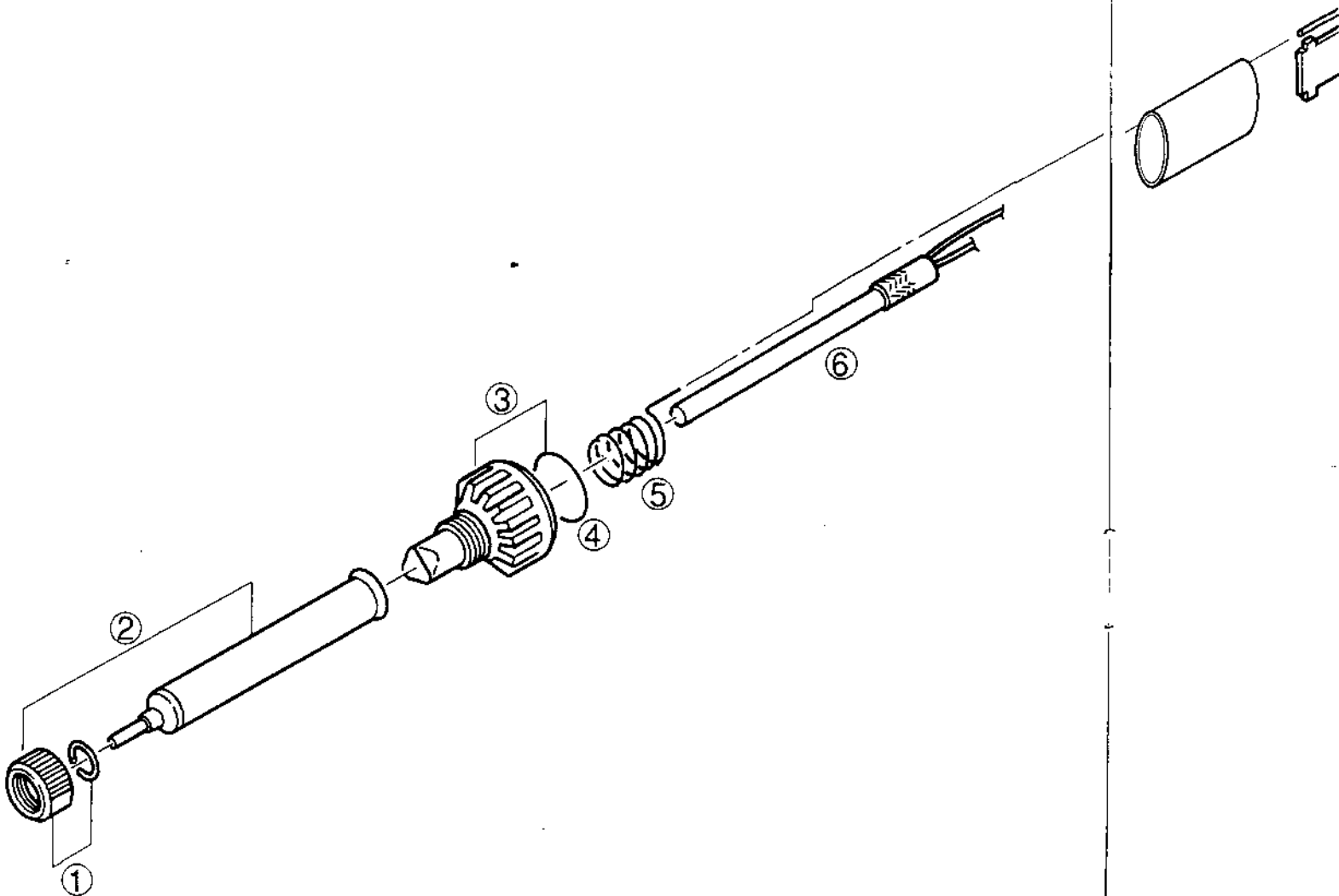

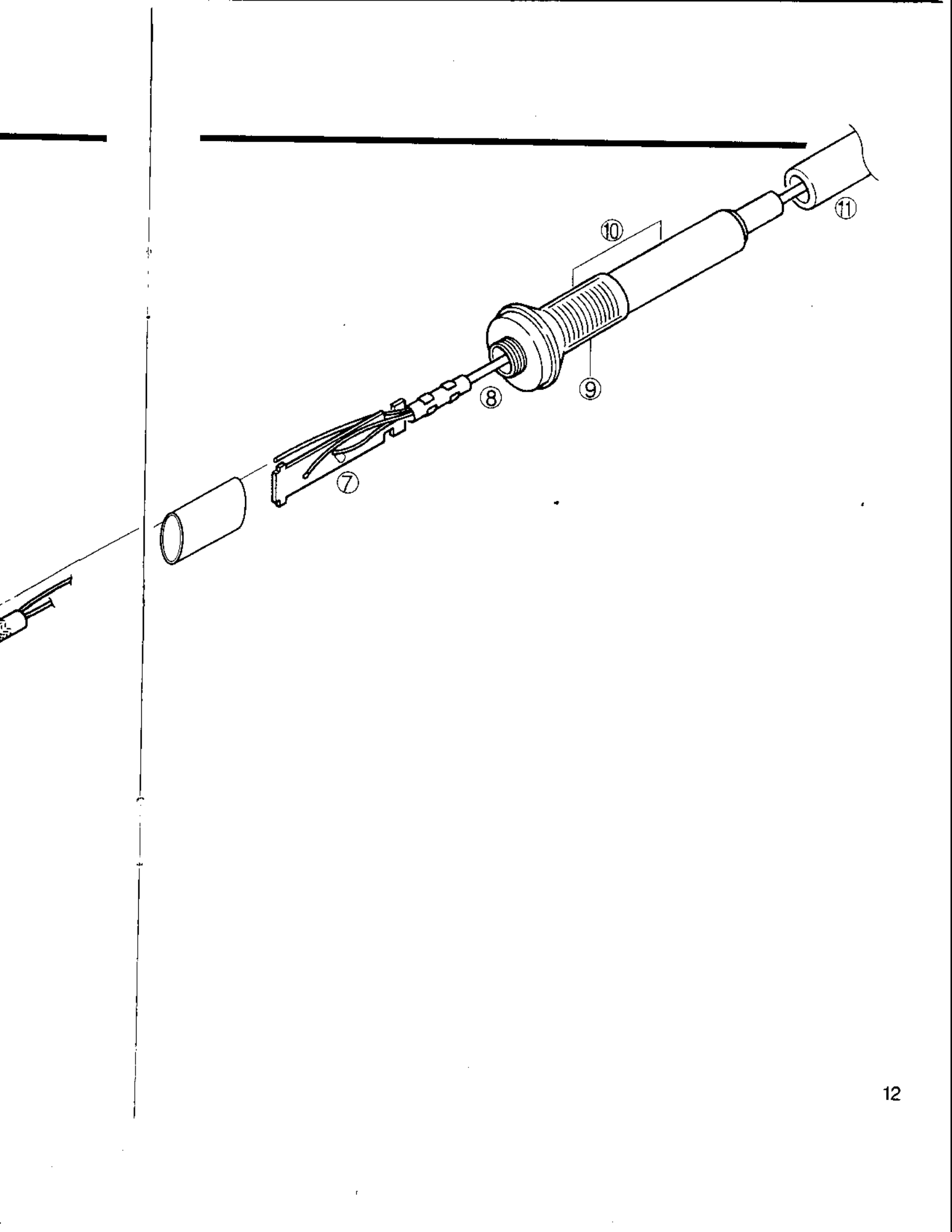

# Temperature Distribution Charts

(Measurement conditions: Maximum air temperature measured 2mm (0.08 in) from blow exit aperture)

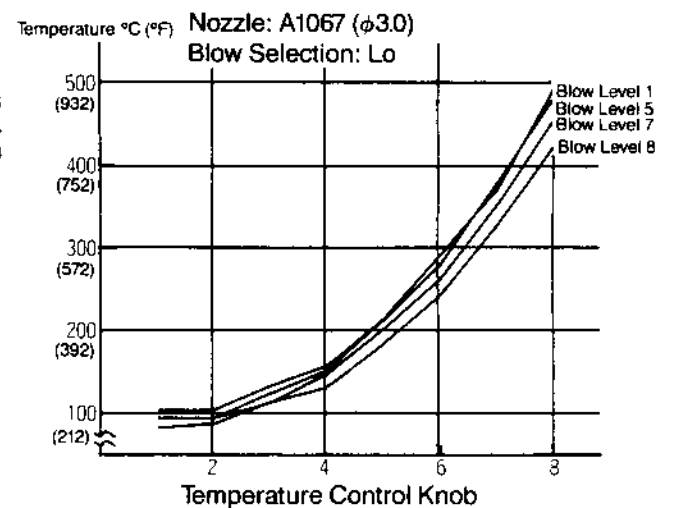
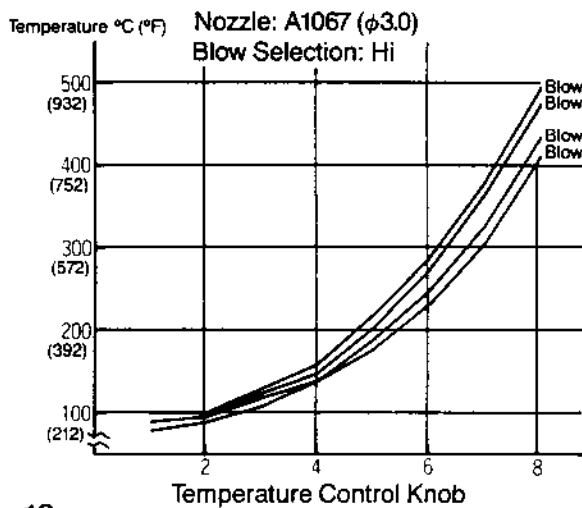
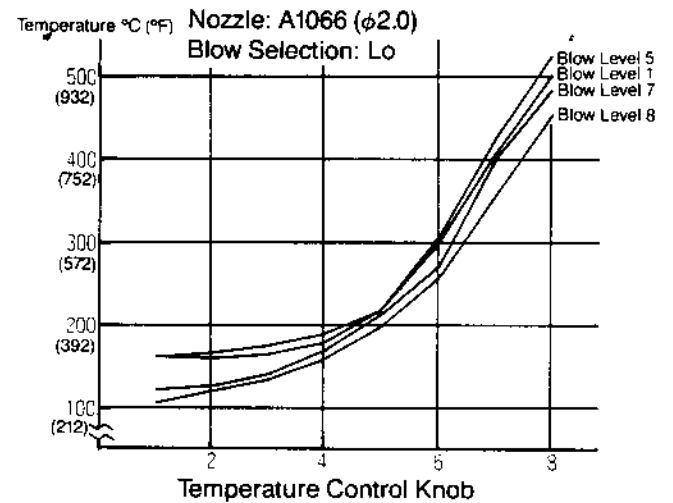
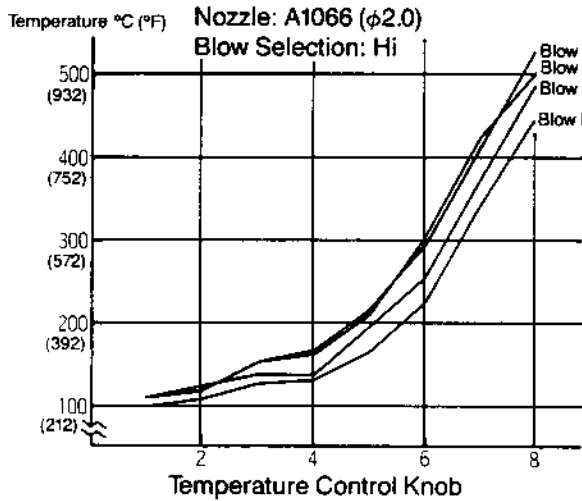
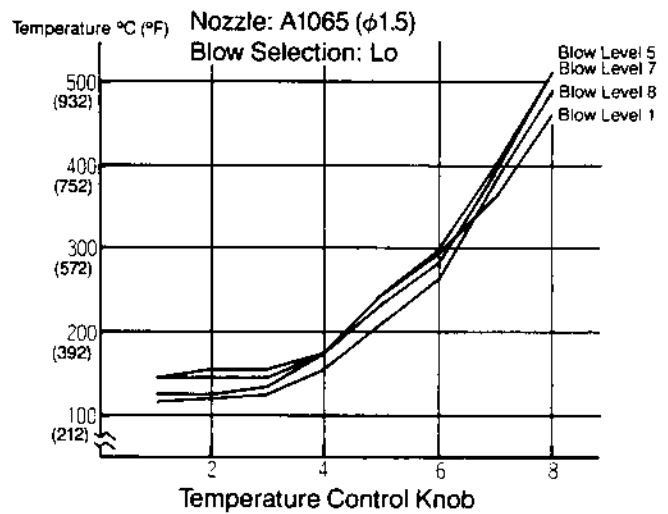
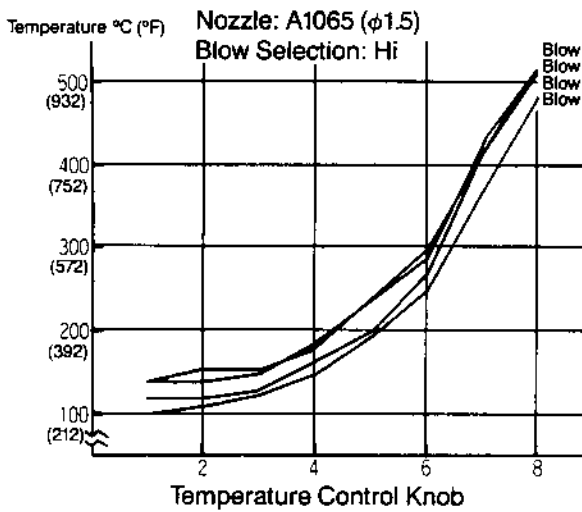

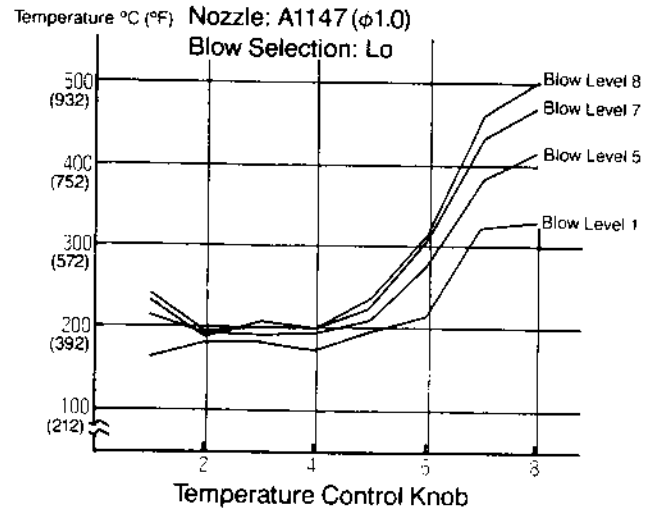
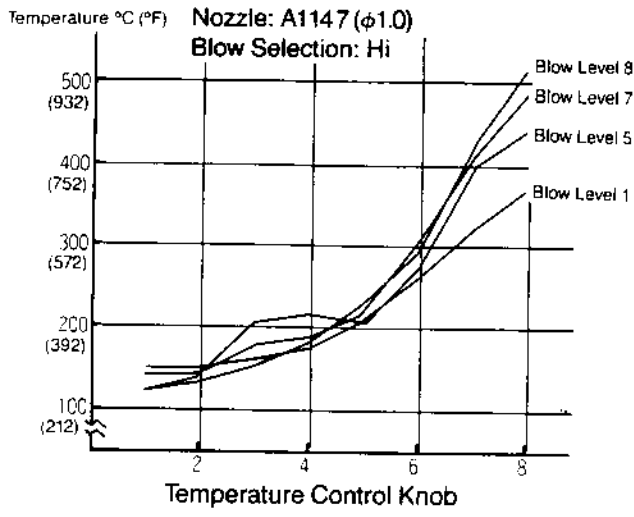





**HEAD OFFICE**

4-5, SHIOKUSA 2-CHOME, NANIWA-KU, OSAKA, 558-0024 JAPAN  
TEL: +81-6-6561-3225 FAX: +81-6-6561-8466

**OVERSEAS AFFILIATES**

U.S.A.: AMERICAN HAKKO PRODUCTS, INC.  
25072 ANZA DR. SANTA CLARITA, CA 91355, U.S.A.  
TEL: (661) 294-0090 FAX: (661) 294-0096  
Toll Free (800)88-HAKKO [www.hakkousa.com](http://www.hakkousa.com)

2 3 3 6

Mar.1999

# HAKKO 851

SMD REWORK STATION

## Replacing the Heating Element

The resistance value of a working Heating Element are approximately 25-30 Ohms (100V, 110V), 40-55 Ohms (120V), 45-60 Ohms (220-240V) at 23°C (73°F). If the value you get is outside this range, replace the Heating Element.

### 1 Disassemble the Air Nozzle

- Remove the Cover from the unit.
- Loosen the Packing Retainer on the rear of the Panel.

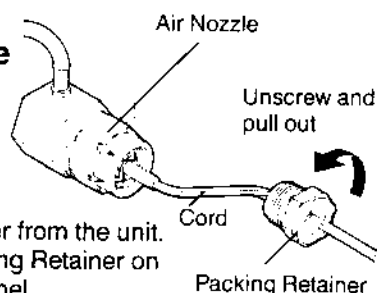

### 2 Disassemble the Iron

- Remove the Nut, Nozzle and Nipple in that order.

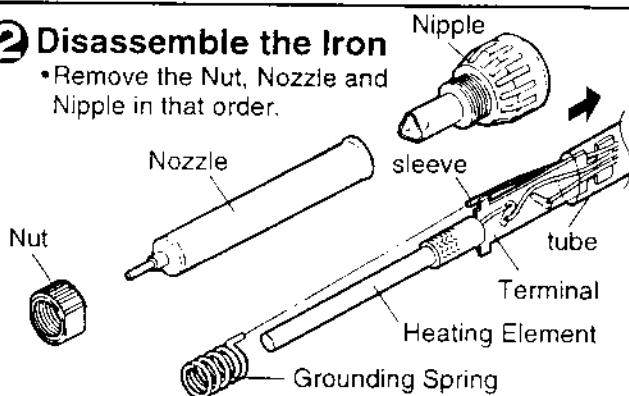

- Slide the tube off of the Terminal in the direction indicated by the arrow, then detach the Grounding Spring from the sleeve.

### 3 Pull out the Heating Element

- Pull the Silicone Hose so it is straight and then pull out the Heating Element from the Handle, along with each of the Cords.

**CAUTION** If the Cords are caught inside the Silicone Hose and do not move freely, press down on it lightly from above.

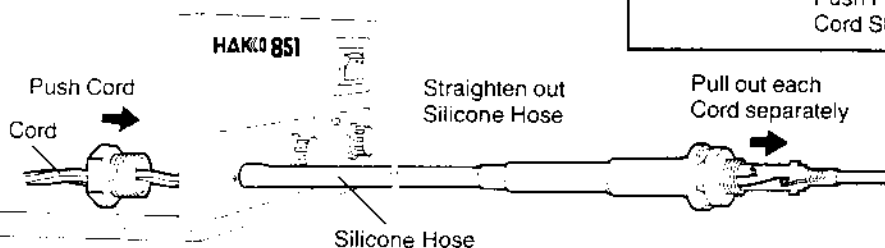

**Note** Should the HAKKO 851 ever need repair, please send both the Iron and the Station to your HAKKO agent.



## HAKKO CORPORATION

### HEAD OFFICE

4-5, SHIOKUSA 2-CHOME, NANIWA-KU, OSAXA 556-0024 JAPAN  
TEL: (06) 561-3225 FAX: (06) 561-8466  
TLX: HAKKOOSA J65274

### OVERSEAS AFFILIATES

U.S.A.: AMERICAN HAKKO PRODUCTS, INC.  
TEL: (805) 294-0090 FAX: (805) 294-0096  
Toll Free: 800/88-HAKKO

SINGAPORE: HAKKO PRODUCTS PTE., LTD.  
TEL: 7482277 FAX: 7410033

HONG KONG: HAKKO DEVELOPMENT CO., LTD.

TEL: 2811-5888 FAX: 2590-0217

PHILIPPINES: HAKKO PHILS TRADING CO., INC.

TEL: 2-817-07-12 FAX: 2-810-16-49

### NOTE TO THE USER

Effective February 14th 1999 the area code on phone and fax number of U.S.A. AMERICAN HAKKO PRODUCTS INC. is changed as follows:  
Former: TEL: (805) 294-0090 FAX: (805) 294-0096  
New: TEL: (805) 294-0090 FAX: (805) 294-0096

MALAYSIA: HAKKO PRODUCTS SDN BHD

MALAYSIA HEAD OFFICE: PETALING JAYA

TEL: 03-7941333 FAX: 03-7911232

PENANG BRANCH:

TEL: 04-644 6669 FAX: 04-644 9628

JOHORE BAHRU BRANCH:

TEL: 07-236 7766 FAX: 07-236 4650

No.	Part Name/Specification
A1064	Heating Element/100V - 80W, Ceramic
A1071	Heating Element/110V - 80W, Ceramic
A1068	Heating Element/120V - 80W, Ceramic
A1070	Heating Element/220V - 80W, Ceramic
A1072	Heating Element/230V - 80W, Ceramic
A1073	Heating Element/240V - 80W, Ceramic

### 4 Replace Heating Element

- Using a stripper or other desoldering tool, remove the solder from the soldered section of the Terminal, then remove the old Heating Element.
- Set the new Heating Element in place as shown in the figures at right.
- Solder the lead wire of the Heating Element to the Terminal.

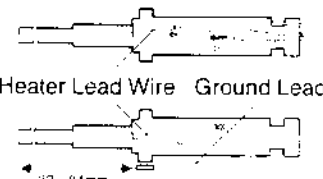

**CAUTION** Make sure that the insulation tubes on the heating element lead wires completely cover the lead wires when the heating element is put into place. If the lead wires are showing this will cause the heating element to protrude too far from the terminal board and block the air flow out of the nozzle. Confirm that the distance between the tip of the heating element and the terminal is 82-84mm (3.2in - 3.3in.)

### 5 Reassemble the Iron

- Attach the Grounding Spring to the sleeve, then slide the tube back over the Terminal.
- Pull the Cord from the Air Nozzle side to insert the Terminal back in the Handle.
- Attach the Nipple, Nozzle and Nut.

**CAUTION** The Silicone Hose should be straight while this is done. Also, be sure to pull all 3 Cords (2 white, 1 green) together.

### 6 Reassemble Air Nozzle

- Push the Packing and Cord Stopper through the Tube and insert in the Air Nozzle.

#### CAUTION

Be sure to push the Packing and Cord Stopper through the Tube in order to prevent air leakage.

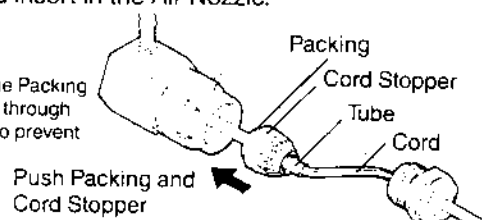

Push Packing and Cord Stopper

- Screw on the Packing Retainer.
- Replace the Cover on the unit.

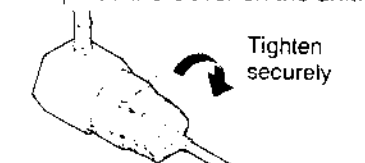

Tighten securely

### 7 Calibrate the temperature

After replacing the Heating Element, be sure to calibrate the temperature to ensure accurate temperature control.

- Attach  $\phi 2.0\text{mm}$  (0.08 in.) Nozzle and set the Blow Selector Switch to Hi. Set the Temperature Control Knob to "8" and the Air Flow Control Knob to "5", then heat the Nozzle for two (2) minutes.
- Using a screwdriver, adjust the CAL control until the temperature of the air 2mm (0.08 in) from the blow exit aperture is 540°C (1004°F).

\* Turn the Temperature Calibrator clockwise to raise the Nozzle temperature and counterclockwise to lower it