



Chipsmall Limited consists of a professional team with an average of over 10 year of expertise in the distribution of electronic components. Based in Hongkong, we have already established firm and mutual-benefit business relationships with customers from,Europe,America and south Asia,supplying obsolete and hard-to-find components to meet their specific needs.

With the principle of “Quality Parts,Customers Priority,Honest Operation,and Considerate Service”,our business mainly focus on the distribution of electronic components. Line cards we deal with include Microchip,ALPS,ROHM,Xilinx,Pulse,ON,Everlight and Freescale. Main products comprise IC,Modules,Potentiometer,IC Socket,Relay,Connector.Our parts cover such applications as commercial,industrial, and automotives areas.

We are looking forward to setting up business relationship with you and hope to provide you with the best service and solution. Let us make a better world for our industry!



Contact us

Tel: +86-755-8981 8866 Fax: +86-755-8427 6832

Email & Skype: info@chipsmall.com Web: www.chipsmall.com

Address: A1208, Overseas Decoration Building, #122 Zhenhua RD., Futian, Shenzhen, China



Emergency stop and safety guard monitoring 2 channels KNE3-YS Part number 85102436



- "Emergency stop" & "Safety gates monitoring" functions
- Single and 2-channel operation
- Security with redundancy and feedback circuit
- 3 "NO" security contacts
- 1 "NC" monitoring contact
- Security category 4 (according to EN 954-1)
- Performance Level (PL) e, safety category 4 to EN ISO 13849-1
- SIL Claimed Level (SIL CL) 3 to IEC/EN 62061
- Terminals : fixed screw terminals or plugin cage clamp terminals

Part numbers

Type	Terminals	Voltages	Supply frequency range (Hz)	Outputs
85102436 KNE3-YS	Screws	24 VAC/DC	50/60	3 NO + 1 NC

Specifications

Operating characteristics

Functions	Emergency stop Safety gates monitoring
Operation	1 or 2 channels
Control input	Manual restart with On-button (Y1 - Y2 terminals) Automatic restart (switch S2 & Y1 - Y2 linked)
Failure detection	Monitored start on On-button With or without cross fault monitoring in the emergency-stop loop (switch S1)
Display of output state by LED	Power supply : PWR Output : OUT1 (relay K1) Output : OUT2 (relay K2)

Supply

Supply voltage	85 102 436 / 85 103 436 : 24 V AC/DC 85 102 434 : 110-115 VAC 85 102 435 : 230 VAC
Supply frequency range (Hz)	50 / 60
Operating range	AC/DC : $\pm 10\%$ Un AC : -15% $+10\%$ Un
Consumption	1,5 W (24 VDC) 3,7 VA (230 VAC)
Initialization time	250 ms

Precision

Maximum reset time	30 ms (manual start) 350 ms (automatic start)
Maximum response time on emergency stop	150 ms (AC/DC) 50 ms (AC)

Output specification

Type	Forcibly guided relays (positively driven)
Number of safety circuits	3 NO
Number of data circuits	1 NC
Nominal output voltage	250 V AC max.
Max. thermal current I for each contact	8 A
Maximum power rating	According to AC15 (NO contacts) : 3 A / 230 V AC According to AC15 (NC contacts) : 2 A / 230 VAC According to DC13 (NO contacts) : 4 A / 24 VDC ; 0,5 A / 110 VDC According to DC13 (NC contacts) : 4 A / 24 VDC
Electrical endurance	At 5 A, 230 VAC, $\cos \varphi = 1$: $1,5 \times 10^5$ switching cycles At 8 A, 24 VDC, according to DC 13 (NO contacts) : 25×10^3 switching cycles (ON : 0,4 s ; OFF : 9,6 s)
Mechanical life	20×10^6 switching cycles
Maximum rate	1200 switching cycles / h
Protection against short circuits	Max. fuse rating : 10 A gL Line circuit breaker : B 6 A

Climatic environment

Operating temperature ($^{\circ}$ C)	-15 \rightarrow +55
Storage temperature ($^{\circ}$ C)	-25 \rightarrow +85
Altitude	< 2000 m
Climate resistance according to IEC/EN 60068-1	15 / 055 / 04

Mechanical environment

Vibration resistance according to IEC/EN 60068-2-6	Amplitude : 0,35 mm Frequency : 10 →55 Hz
--	--

Electromagnetic environment

Immunity to electrostatic discharges acc. IEC/EN 61000-4-2	8 kV (air)
Immunity to radiated, radio-frequency, electromagnetic field acc. IEC/EN 61000-4-3	10 V / m
Immunity to rapid transient bursts acc. to IEC/EN 61000-4-4	2 kV
Immunity to shock waves according to IEC/EN 61000-4-5	Between wires for power supply : 1 kV (AC), 0,5 kV (24 V AC/DC) Between wires and ground : 2 kV
Immunity to radio frequency in common mode acc. to IEC/EN 61000-4-6	10 V
Interference suppression according to IEC/EN 55011	Limit value class B

Housing

Material : self-extinguishing (UL94VO)	Thermoplastic with V0 extinction behaviour
Protection (IEC/EN 60529) - Casing	IP40
Protection (IEC/EN 60529) - Term. block	IP20
Mounting	DIN-rail
Weight (g)	210 (24 VAC/DC) 275 (230 VAC)

Safety standards

Approvals	CE, TÜV, UL / CSA
Environmental directive 2002/95/CE	RoHS
Environmental regulation 1907/2006	Reach
Security data according to EN ISO 13849-1	Performance Level (PL) : e Category : 4
SIL Claimed Level (SIL CL) to IEC/EN 62061	3
Safety Integrity Level (SIL) according to CEI/EN 61508	3
Safety category to EN 954-1	4

Principles

EN ISO 13849-1:		
Category:	4	
PL:	e	
MTTF _d :	> 100	a (year)
DC _{avg} :	99,0	%
d _{op} :	365	d/a (days/year)
h _{op} :	24	h/d (hours/day)
t _{cycle} :	3600	s/cycle
	≅ 1	/h (hour)

IEC/EN 62061 IEC/EN 61508:		
SIL CL:	3	IEC/EN 62061
SIL	3	IEC/EN 61508
HFT ^{*)} :	1	
DC _{avg} :	99,0	%
SFF	99,7	%
PFH _D :	2,66E-10	h ⁻¹
*) HFT = Hardware failure tolerance		

Dimensions (mm)



Dimensions (mm)

KNE3-YS - Screw terminals

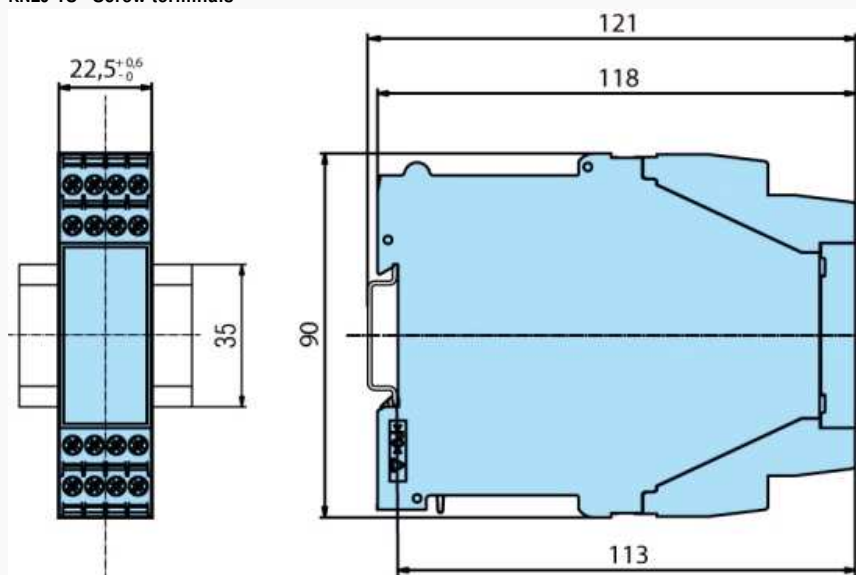

Curves

Function diagram

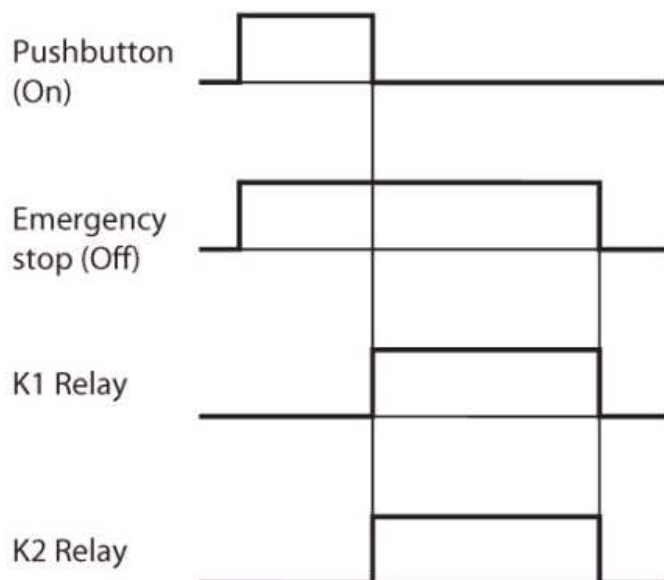

Connections

Front face drawing KNE3-YS

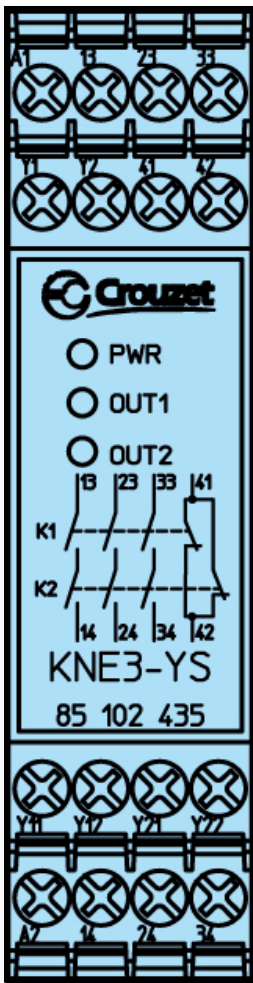

Connections

Contacts

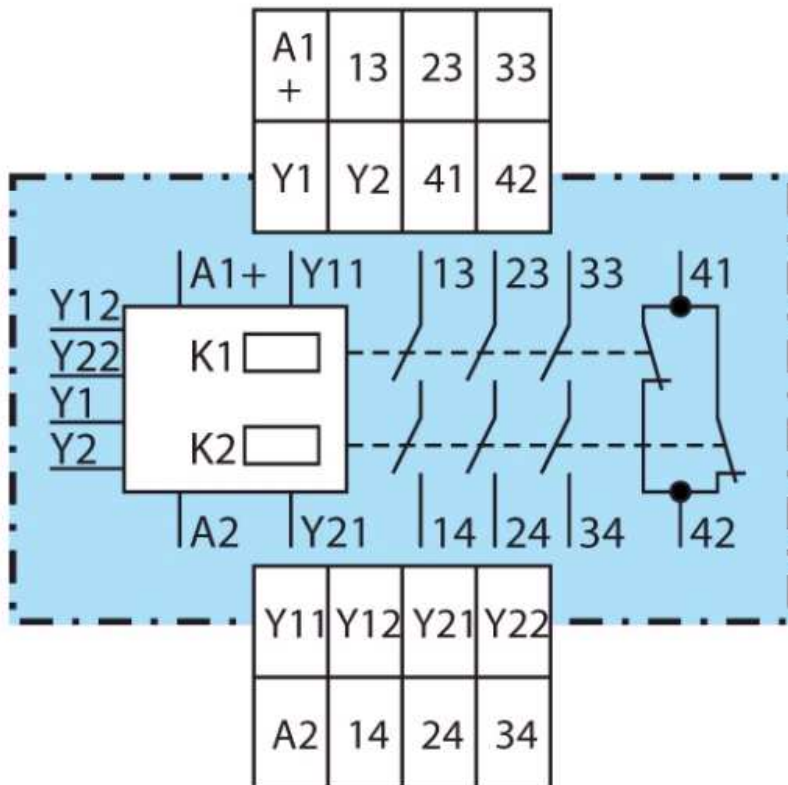

A1 (+) : + / L A2 : - / N Y1, Y2 : Validation Input Y11, Y21, Y12, Y22 : Control Inputs 13, 14, 23, 24, 33, 34 : Safety circuit outputs (forcibly guided NO contacts) 41, 42 : Monitoring output (forcibly

Applications

Single channel emergency stop circuit

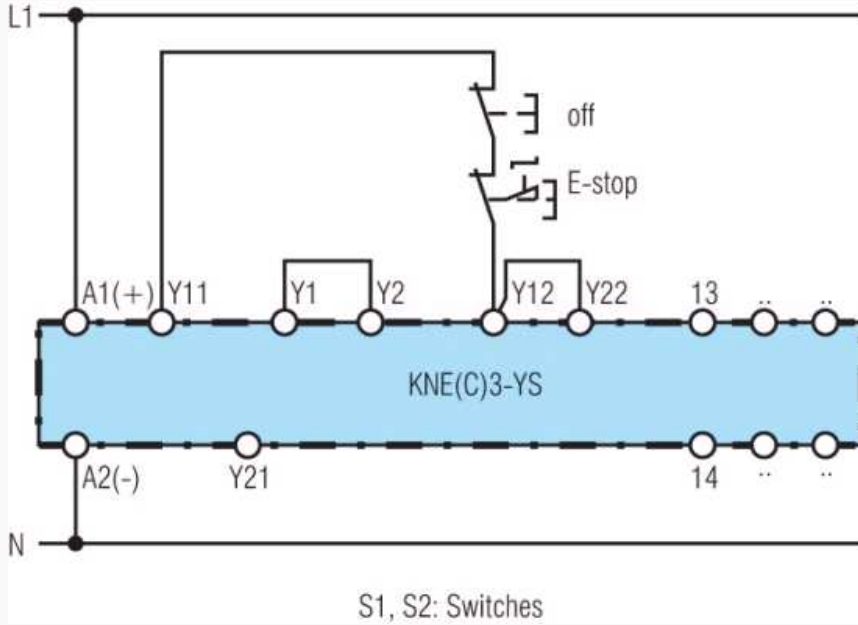

This circuit does not have any redundancy in the emergency-stop control circuit. S1 : no cross fault detection S2 : automatic start

Applications

2-channel emergency stop circuit without cross fault monitoring

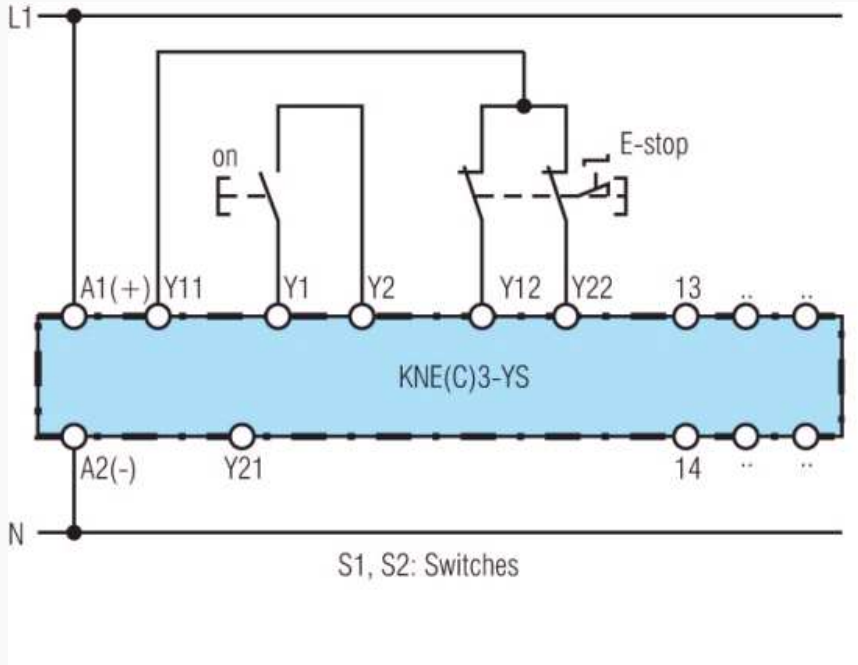

S1 : no cross fault detection S2 : manual start

Applications

Contact reinforcement by external contactors controlled by one contact path

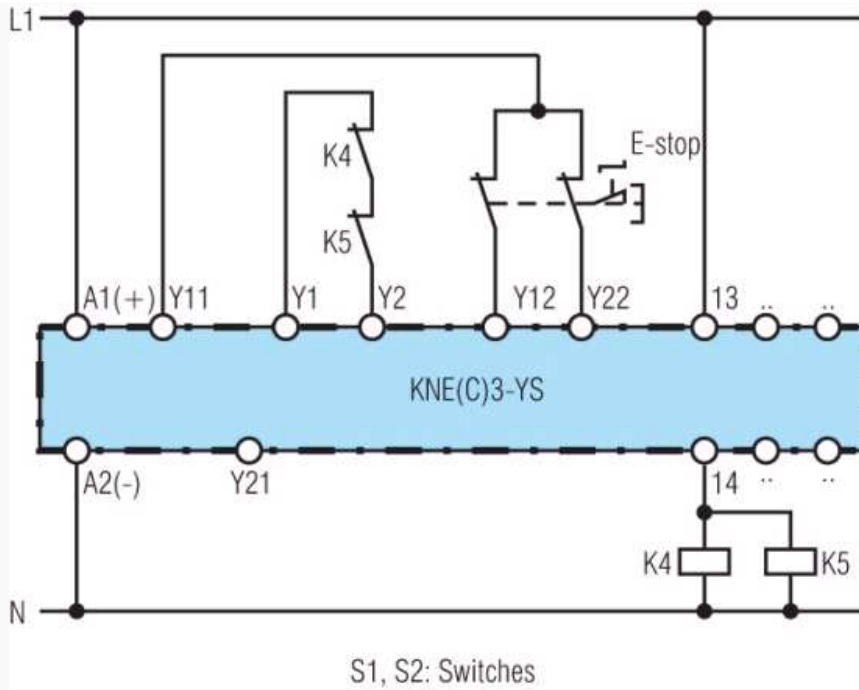

S1 : no cross fault detection S2 : automatic start

Applications

2-channel safety gate monitoring

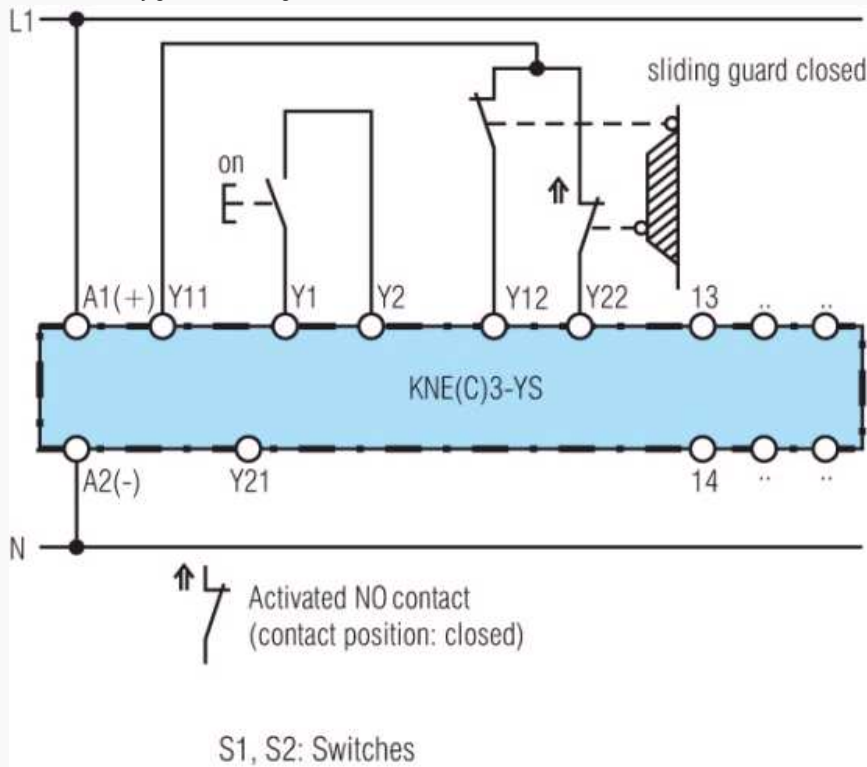

S1 : no cross fault detection S2 : manual start

Applications

Contact reinforcement by external contactors, 2-channel controlled

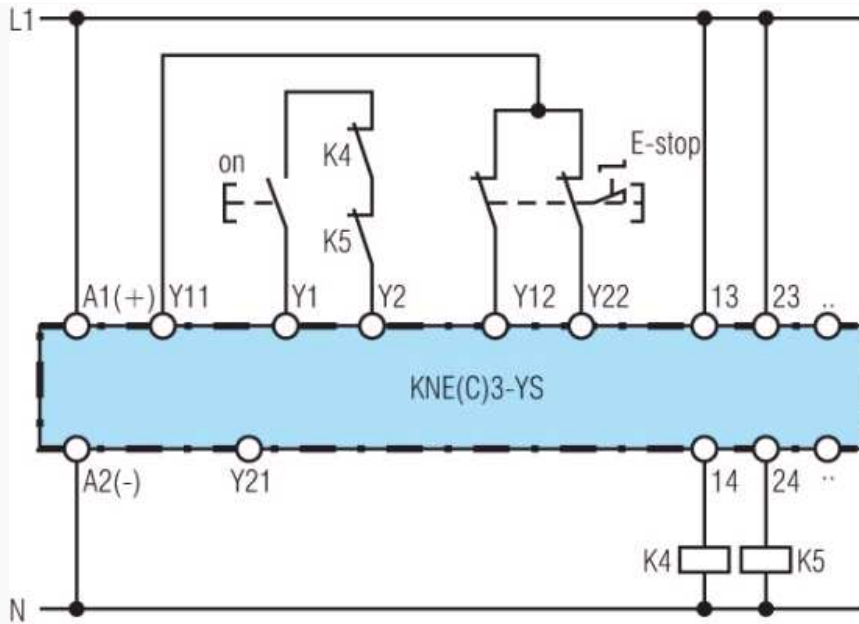

S1, S2: Switches

For currents > 8 A, the output contacts can be reinforced by external contactors. Functioning of the external contactors is monitored by looping the NC contacts into the start circuit (Y1-Y2)

Applications

2-channel emergency stop circuit with cross fault monitoring

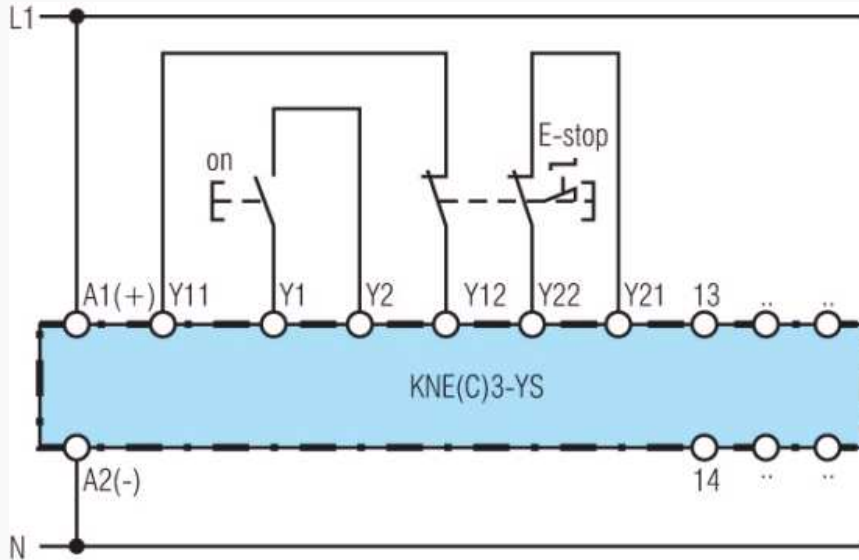

S1, S2: Switches

S1 : cross fault detection S2 : manual start