



Chipsmall Limited consists of a professional team with an average of over 10 year of expertise in the distribution of electronic components. Based in Hongkong, we have already established firm and mutual-benefit business relationships with customers from,Europe,America and south Asia,supplying obsolete and hard-to-find components to meet their specific needs.

With the principle of “Quality Parts,Customers Priority,Honest Operation,and Considerate Service”,our business mainly focus on the distribution of electronic components. Line cards we deal with include Microchip,ALPS,ROHM,Xilinx,Pulse,ON,Everlight and Freescale. Main products comprise IC,Modules,Potentiometer,IC Socket,Relay,Connector.Our parts cover such applications as commercial,industrial, and automotives areas.

We are looking forward to setting up business relationship with you and hope to provide you with the best service and solution. Let us make a better world for our industry!



## Contact us

Tel: +86-755-8981 8866 Fax: +86-755-8427 6832

Email & Skype: info@chipsmall.com Web: www.chipsmall.com

Address: A1208, Overseas Decoration Building, #122 Zhenhua RD., Futian, Shenzhen, China



## GENERAL DESCRIPTION

The 85322 is a Dual LVCMOS / LVTTTL-to-Differential 2.5V / 3.3V LVPECL translator. The 85322 has selectable single ended clock inputs. The single ended clock input accepts LVCMOS or LVTTTL input levels and translate them to 2.5V / 3.3V LVPECL levels. The small outline 8-pin SOIC package makes this device ideal for applications where space, high performance and low power are important.

## FEATURES

- Two differential 2.5V/3.3V LVPECL outputs
- Selectable CLK0, CLK1 LVCMOS/LVTTTL clock inputs
- CLK0 and CLK1 can accept the following input levels: LVCMOS or LVTTTL
- Maximum output frequency: 267MHz
- Part-to-part skew: 250ps (maximum)
- 3.3V operating supply voltage (operating range 3.135V to 3.465V)
- 2.5V operating supply voltage (operating range 2.375V to 2.625V)
- 0°C to 70°C ambient operating temperature
- Lead-Free package available

## BLOCK DIAGRAM

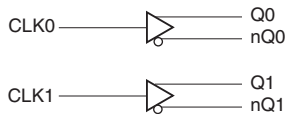

## PIN ASSIGNMENT

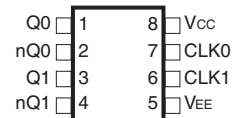

### 85322

#### 8-Lead SOIC

3.90mm x 4.92mm x 1.37mm body package

#### M Package

Top View

**TABLE 1. PIN DESCRIPTIONS**

Number	Name	Type		Description
1, 2	Q0, nQ0	Output		Differential output pair. LVPECL interface levels.
3, 4	Q1, nQ1	Output		Differential output pair. LVPECL interface levels.
5	V <sub>EE</sub>	Power		Negative supply pin.
6	CLK1	Input	Pullup	LVC MOS / LV TTL clock input.
7	CLK0	Input	Pullup	LVC MOS / LV TTL clock input.
8	V <sub>CC</sub>	Power		Positive supply pin.

NOTE: *Pullup* refers to internal input resistors. See Table 2, Pin Characteristics, for typical values.

**TABLE 2. PIN CHARACTERISTICS**

Symbol	Parameter	Test Conditions	Minimum	Typical	Maximum	Units
C <sub>IN</sub>	Input Capacitance			4		pF
R <sub>PULLUP</sub>	Input Pullup Resistor			51		kΩ

**ABSOLUTE MAXIMUM RATINGS**

Supply Voltage, $V_{CC}$	4.6V
Inputs, $V_I$	-0.5V to $V_{CC} + 0.5V$
Outputs, $I_O$	
Continuous Current	50mA
Surge Current	100mA
Package Thermal Impedance, $\theta_{JA}$	112.7°C/W (0 lfpm)
Storage Temperature, $T_{STG}$	-65°C to 150°C

NOTE: Stresses beyond those listed under Absolute Maximum Ratings may cause permanent damage to the device. These ratings are stress specifications only. Functional operation of product at these conditions or any conditions beyond those listed in the *DC Characteristics* or *AC Characteristics* is not implied. Exposure to absolute maximum rating conditions for extended periods may affect product reliability.

**TABLE 3A. POWER SUPPLY DC CHARACTERISTICS,  $V_{CC} = 3.3V \pm 5\%$ ,  $T_A = 0^\circ C$  TO  $70^\circ C$** 

Symbol	Parameter	Test Conditions	Minimum	Typical	Maximum	Units
$V_{CC}$	Positive Supply Voltage		3.135	3.3	3.465	V
$I_{EE}$	Power Supply Current				25	mA

**TABLE 3B. LVCMOS / LVTTTL DC CHARACTERISTICS,  $V_{CC} = 3.3V \pm 5\%$ ,  $T_A = 0^\circ C$  TO  $70^\circ C$** 

Symbol	Parameter	Test Conditions	Minimum	Typical	Maximum	Units
$V_{IH}$	Input High Voltage	CLK0, CLK1	2		3.765	V
$V_{IL}$	Input Low Voltage	CLK0, CLK1	-0.3		1.3	V
$I_{IH}$	Input High Current	CLK0, CLK1 $V_{CC} = V_{IN} = 3.465V$			5	$\mu A$
$I_{IL}$	Input Low Current	CLK0, CLK1 $V_{CC} = V_{IN} = 3.465V$	-150			$\mu A$

**TABLE 3C. LVPECL DC CHARACTERISTICS,  $V_{CC} = 3.3V \pm 5\%$ ,  $T_A = 0^\circ C$  TO  $70^\circ C$** 

Symbol	Parameter	Test Conditions	Minimum	Typical	Maximum	Units
$V_{OH}$	Output High Voltage; NOTE 1	$V_{CC} = V_{IN} = 3.465V$	$V_{CC} - 1.4$		$V_{CC} - 0.9$	V
$V_{OL}$	Output Low Voltage; NOTE 1	$V_{CC} = V_{IN} = 3.465V$	$V_{CC} - 2.0$		$V_{CC} - 1.7$	V
$V_{SWING}$	Peak-to-Peak Output Voltage Swing		0.65		1.0	V

NOTE 1: Outputs terminated with  $50\Omega$  to  $V_{CC} - 2V$ .

**TABLE 4A. AC CHARACTERISTICS,  $V_{CC} = 3.3V \pm 5\%$ ,  $T_A = 0^\circ C$  TO  $70^\circ C$** 

Symbol	Parameter	Test Conditions	Minimum	Typical	Maximum	Units
$f_{MAX}$	Output Frequency				267	MHz
$t_{PD}$	Propagation Delay; NOTE 1	$f \leq 267MHz$	0.6		1.8	ns
tsk(pp)	Part-to-Part Skew; NOTE 2, 3				250	ps
$t_R / t_F$	Output Rise/Fall Time	20% to 80% @ 50MHz	300		700	ps
odc	Output Duty Cycle		40		60	%

All parameters measured at 133MHz unless noted otherwise.

NOTE 1: Measured from  $V_{CC}/2$  of the input to the differential output crossing point.

NOTE 2: Defined as skew between outputs on different devices operating at the same supply voltages and with equal load conditions. Using the same type of inputs on each device, the outputs are measured at the differential cross points.

NOTE 3: This parameter is defined in accordance with JEDEC Standard 65.

**TABLE 3D. POWER SUPPLY DC CHARACTERISTICS,  $V_{CC} = 2.5V \pm 5\%$ ,  $T_A = 0^\circ C$  TO  $70^\circ C$** 

Symbol	Parameter	Test Conditions	Minimum	Typical	Maximum	Units
$V_{CC}$	Positive Supply Voltage		2.375	2.5	2.625	V
$I_{EE}$	Power Supply Current				25	mA

**TABLE 3E. LVCMOS / LVTTTL DC CHARACTERISTICS,  $V_{CC} = 2.5V \pm 5\%$ ,  $T_A = 0^\circ C$  TO  $70^\circ C$** 

Symbol	Parameter	Test Conditions	Minimum	Typical	Maximum	Units
$V_{IH}$	Input High Voltage	CLK0, CLK1	1.6		2.925	V
$V_{IL}$	Input Low Voltage	CLK0, CLK1	-0.3		0.9	V
$I_{IH}$	Input High Current	CLK0, CLK1 $V_{CC} = V_{IN} = 2.625$			5	$\mu A$
$I_{IL}$	Input Low Current	CLK0, CLK1 $V_{CC} = V_{IN} = 2.625$	-150			$\mu A$

**TABLE 3F. LVPECL DC CHARACTERISTICS,  $V_{CC} = 2.5V \pm 5\%$ ,  $T_A = 0^\circ C$  TO  $70^\circ C$** 

Symbol	Parameter	Test Conditions	Minimum	Typical	Maximum	Units
$V_{OH}$	Output High Voltage; NOTE 1		$V_{CC} - 1.4$		$V_{CC} - 0.9$	V
$V_{OL}$	Output Low Voltage; NOTE 1		$V_{CC} - 2.0$		$V_{CC} - 1.7$	V
$V_{SWING}$	Peak-to-Peak Output Voltage Swing		0.65		1.0	V

NOTE 1: Outputs terminated with  $50\Omega$  to  $V_{CC} - 2V$ .

**TABLE 4B. AC CHARACTERISTICS,  $V_{CC} = 2.5V \pm 5\%$ ,  $T_A = 0^\circ C$  TO  $70^\circ C$** 

Symbol	Parameter	Test Conditions	Minimum	Typical	Maximum	Units
$f_{MAX}$	Output Frequency				215	MHz
$t_{PD}$	Propagation Delay; NOTE 1	$f \leq 215MHz$	0.8		2	ns
tsk(pp)	Part-to-Part Skew; NOTE 2, 3				250	ps
$t_R / t_F$	Output Rise/Fall Time	20% to 80% @ 50MHz	300		700	ps
odc	Output Duty Cycle		40		60	%

All parameters measured at 133MHz unless noted otherwise.

NOTE 1: Measured from  $V_{CC}/2$  of the input to the differential output crossing point.

NOTE 2: Defined as skew between outputs on different devices operating at the same supply voltages and with equal load conditions. Using the same type of inputs on each device, the outputs are measured at the differential cross points.

NOTE 3: This parameter is defined in accordance with JEDEC Standard 65..

## PARAMETER MEASUREMENT INFORMATION

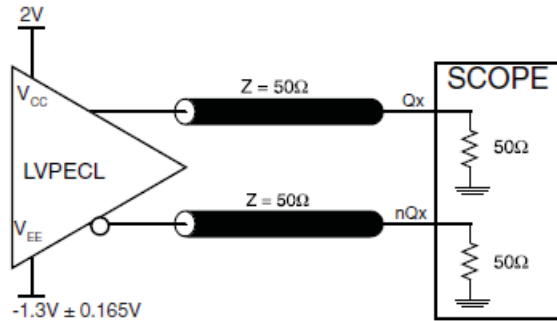
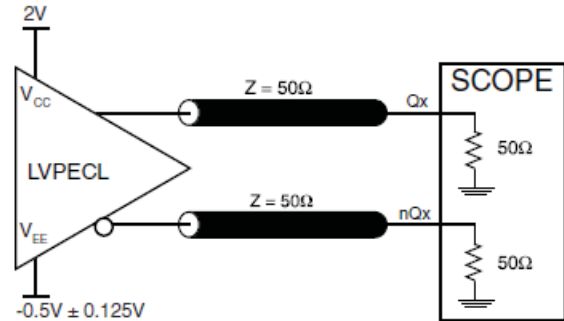
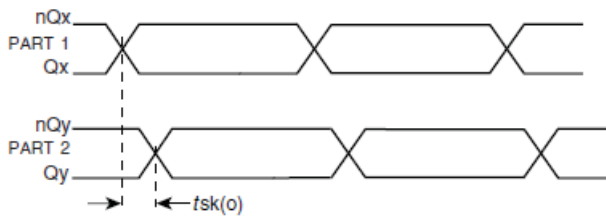
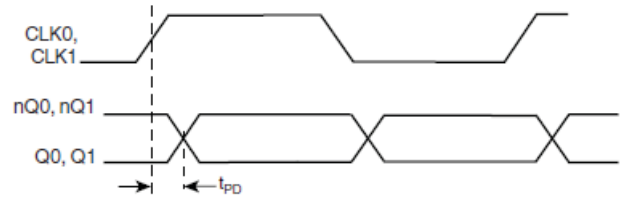
**3.3V OUTPUT LOAD AC TEST CIRCUIT**

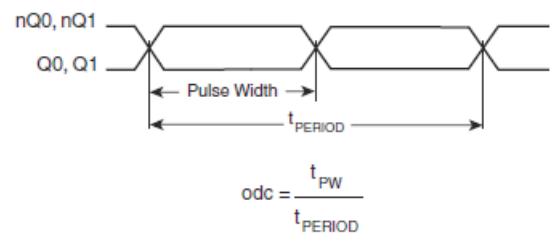
**2.5V OUTPUT LOAD AC TEST CIRCUIT**

**PART-TO-PART SKEW**

**PROPAGATION DELAY**

**OUTPUT RISE/FALL TIME**

**OUTPUT DUTY CYCLE/PULSE WIDTH/PERIOD**

## APPLICATION INFORMATION

### TERMINATION FOR LVPECL OUTPUTS

The clock layout topology shown below is a typical termination for LVPECL outputs. The two different layouts mentioned are recommended only as guidelines.

FOUT and nFOUT are low impedance follower outputs that generate ECL/LVPECL compatible outputs. Therefore, terminating resistors (DC current path to ground) or current sources must be used for functionality. These outputs are designed to

drive 50Ω transmission lines. Matched impedance techniques should be used to maximize operating frequency and minimize signal distortion. *Figures 1A and 1B* show two different layouts which are recommended only as guidelines. Other suitable clock layouts may exist and it would be recommended that the board designers simulate to guarantee compatibility across all printed circuit and clock component process variations.

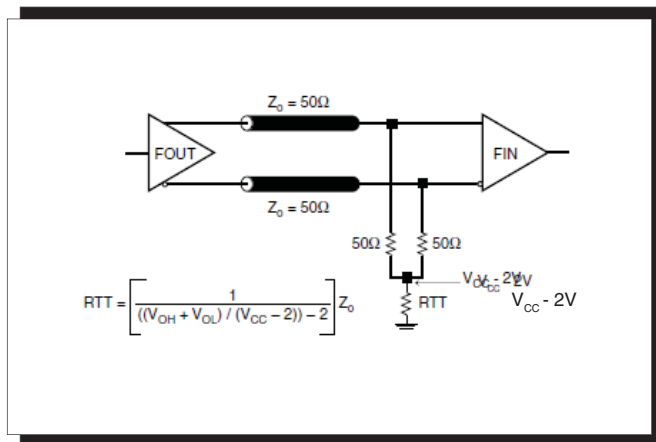

FIGURE 1A. LVPECL OUTPUT TERMINATION

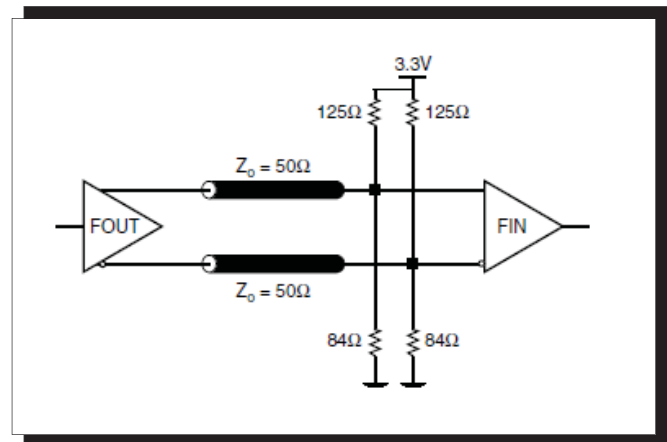

FIGURE 1B. LVPECL OUTPUT TERMINATION

## POWER CONSIDERATIONS

This section provides information on power dissipation and junction temperature for the 85322. Equations and example calculations are also provided.

### 1. Power Dissipation.

The total power dissipation for the 85322 is the sum of the core power plus the power dissipated in the load(s). The following is the power dissipation for  $V_{CC} = 3.3V + 5\% = 3.465V$ , which gives worst case results.

**NOTE:** Please refer to Section 3 for details on calculating power dissipated in the load.

- Power (core)<sub>MAX</sub> =  $V_{CC\_MAX} * I_{EE\_MAX} = 3.465V * 25mA = 86.6mW$
- Power (outputs)<sub>MAX</sub> = **30mW/Loaded Output pair**  
If all outputs are loaded, the total power is  $2 * 30mW = 60mW$

$$\text{Total Power}_{MAX} (3.465V, \text{ with all outputs switching}) = 86.6mW + 60mW = 146.6mW$$

### 2. Junction Temperature.

Junction temperature,  $T_j$ , is the temperature at the junction of the bond wire and bond pad and directly affects the reliability of the device. The maximum recommended junction temperature for the devices is 125°C.

The equation for  $T_j$  is as follows:  $T_j = \theta_{JA} * Pd\_total + T_A$

$T_j$  = Junction Temperature

$\theta_{JA}$  = Junction-to-Ambient Thermal Resistance

$Pd\_total$  = Total Device Power Dissipation (example calculation is in section 1 above)

$T_A$  = Ambient Temperature

In order to calculate junction temperature, the appropriate junction-to-ambient thermal resistance  $\theta_{JA}$  must be used. Assuming a moderate air flow of 200 linear feet per minute and a multi-layer board, the appropriate value is 103.3°C/W per Table 5 below.

Therefore,  $T_j$  for an ambient temperature of 70°C with all outputs switching is:

$$70^\circ C + 0.147W * 103.3^\circ C/W = 85.2^\circ C. \text{ This is well below the limit of } 125^\circ C.$$

This calculation is only an example.  $T_j$  will obviously vary depending on the number of loaded outputs, supply voltage, air flow, and the type of board (single layer or multi-layer).

**TABLE 5. THERMAL RESISTANCE  $\theta_{JA}$  FOR 8-PIN SOIC, FORCED CONVECTION**

	$\theta_{JA}$ by Velocity (Linear Feet per Minute)		
	0	200	500
Single-Layer PCB, JEDEC Standard Test Boards	153.3°C/W	128.5°C/W	115.5°C/W
Multi-Layer PCB, JEDEC Standard Test Boards	112.7°C/W	103.3°C/W	97.1°C/W

**NOTE:** Most modern PCB designs use multi-layered boards. The data in the second row pertains to most designs.



### 3. Calculations and Equations.

The purpose of this section is to derive the power dissipated into the load.

LVPECL output driver circuit and termination are shown in *Figure 2*.

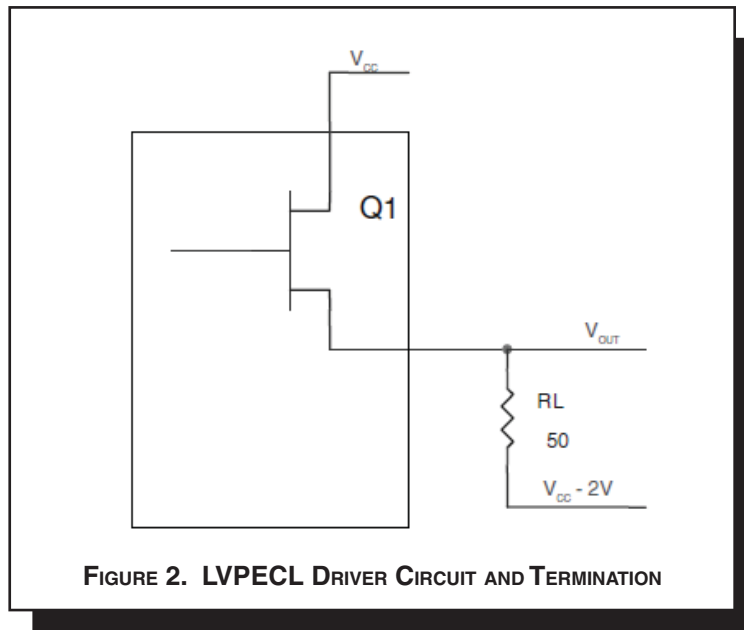

To calculate worst case power dissipation into the load, use the following equations which assume a 50Ω load, and a termination voltage of  $V_{CC} - 2V$ .

- For logic high,  $V_{OUT} = V_{OH\_MAX} = V_{CC\_MAX} - 0.9V$

$$(V_{CC\_MAX} - V_{OH\_MAX}) = 0.9V$$

- For logic low,  $V_{OUT} = V_{OL\_MAX} = V_{CC\_MAX} - 1.7V$

$$(V_{CC\_MAX} - V_{OL\_MAX}) = 1.7V$$

$Pd\_H$  is power dissipation when the output drives high.

$Pd\_L$  is the power dissipation when the output drives low.

$$Pd\_H = [(V_{OH\_MAX} - (V_{CC\_MAX} - 2V))/R_L] * (V_{CC\_MAX} - V_{OH\_MAX}) = [(2V - (V_{CC\_MAX} - V_{OH\_MAX}))/R_L] * (V_{CC\_MAX} - V_{OH\_MAX}) = [(2V - 0.9V)/50\Omega] * 0.9V = \mathbf{19.8mW}$$

$$Pd\_L = [(V_{OL\_MAX} - (V_{CC\_MAX} - 2V))/R_L] * (V_{CC\_MAX} - V_{OL\_MAX}) = [(2V - (V_{CC\_MAX} - V_{OL\_MAX}))/R_L] * (V_{CC\_MAX} - V_{OL\_MAX}) = [(2V - 1.7V)/50\Omega] * 1.7V = \mathbf{10.2mW}$$

Total Power Dissipation per output pair =  $Pd\_H + Pd\_L = \mathbf{30mW}$

## RELIABILITY INFORMATION

**TABLE 6.  $\theta_{JA}$  VS. AIR FLOW TABLE FOR 8 LEAD SOIC**

$\theta_{JA}$ by Velocity (Linear Feet per Minute)			
	<b>0</b>	<b>200</b>	<b>500</b>
Single-Layer PCB, JEDEC Standard Test Boards	153.3°C/W	128.5°C/W	115.5°C/W
Multi-Layer PCB, JEDEC Standard Test Boards	112.7°C/W	103.3°C/W	97.1°C/W

**NOTE:** Most modern PCB designs use multi-layered boards. The data in the second row pertains to most designs.

### TRANSISTOR COUNT

The transistor count for 85322 is: 269

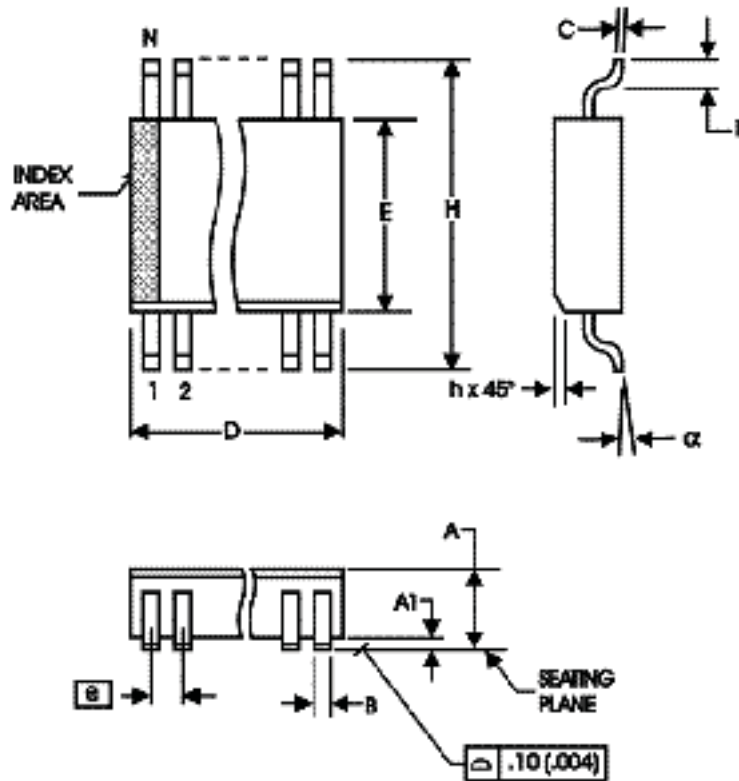
**PACKAGE OUTLINE - M SUFFIX FOR 8 LEAD SOIC**

**TABLE 7. PACKAGE DIMENSIONS**

SYMBOL	Millimeters	
	MINIMUM	MAXIMUM
N	8	
A	1.35	1.75
A1	0.10	0.25
B	0.33	0.51
C	0.19	0.25
D	4.80	5.00
E	3.80	4.00
e	1.27 BASIC	
H	5.80	6.20
h	0.25	0.50
L	0.40	1.27
α	0°	8°

Reference Document: JEDEC Publication 95, MS-012

**TABLE 8. ORDERING INFORMATION**

<b>Part/Order Number</b>	<b>Marking</b>	<b>Package</b>	<b>Shipping Packaging</b>	<b>Temperature</b>
85322AMLF	85322AML	8 lead "Lead-Free" SOIC	tube	0°C to 70°C
85322AMLFT	853322AML	8 lead "Lead-Free" SOIC	tape & reel	0°C to 70°C

REVISION HISTORY SHEET				
Rev	Table	Page	Description of Change	Date
A		9	Added Termination for LVPECL Outputs section.	5/30/02
A		6	3.3V Output Load Test Circuit Diagram, corrected $V_{EE} = -1.3V \pm 0.135V$	8/23/02
		7	to read $V_{EE} = -1.3V \pm 0.165V$ . Updated Output Rise/Fall Time Diagram.	
B	T2 T4A & T4B	2 3 3 & 4 6	Pin Characteristics Table - changed $C_{IN}$ 4pF max. to 4pF typical. Absolute Maximum Rating - changed Outputs rating. 3.3V and 2.5V AC Tables - changed tsk(pp) from 150ps max. to 250ps max. and reflects Features section on page 1. Updated LVPECL Output Termination drawings. Updated format.	6/12/03
B	T8	11	Ordering Information Table - added Lead Free part.	10/18/04
C	T2 T3C T3F T8	2 3 4 7 - 8 11	Pin Characteristics Table - deleted RPulldown row. LVPECL 3.3V DC Characteristics Table -corrected $V_{OH}$ max. from $V_{CC} - 1.0V$ to $V_{CC} - 0.9V$ ; and $V_{SWING}$ max. from 0.85V to 1.0V. LVPECL 2.5V DC Characteristics Table -corrected $V_{OH}$ max. from $V_{CC} - 1.0V$ to $V_{CC} - 0.9V$ ; and $V_{SWING}$ max. from 0.85V to 1.0V. Power Considerations - corrected power dissipation to reflect $V_{OH}$ max in Table 3C & 3F. Ordering Information Table - added lead-free note.	4/11/07
D	T8	11 13	Updated datasheet's header/footer with IDT from ICS. Removed ICS prefix from Part/Order Number column. Added Contact Page.	7/31/10
D	T8	11	Removed ICS from the part number where needed. Ordering Information - Removed leaded parts. Removed quantities for tape and reel. Deleted the LF note below the table. Updated header and footer.	1/20/16

**Corporate Headquarters**

6024 Silver Creek Valley Road  
San Jose, CA 95138 USA  
[www.IDT.com](http://www.IDT.com)

**Sales**

1-800-345-7015 or 408-284-8200  
Fax: 408-284-2775  
[www.IDT.com/go/sales](http://www.IDT.com/go/sales)

**Tech Support**

[www.idt.com/go/support](http://www.idt.com/go/support)

DISCLAIMER Integrated Device Technology, Inc. (IDT) reserves the right to modify the products and/or specifications described herein at any time, without notice, at IDT's sole discretion. Performance specifications and operating parameters of the described products are determined in an independent state and are not guaranteed to perform the same way when installed in customer products. The information contained herein is provided without representation or warranty of any kind, whether express or implied, including, but not limited to, the suitability of IDT's products for any particular purpose, an implied warranty of merchantability, or non-infringement of the intellectual property rights of others. This document is presented only as a guide and does not convey any license under intellectual property rights of IDT or any third parties.

IDT's products are not intended for use in applications involving extreme environmental conditions or in life support systems or similar devices where the failure or malfunction of an IDT product can be reasonably expected to significantly affect the health or safety of users. Anyone using an IDT product in such a manner does so at their own risk, absent an express, written agreement by IDT.

Integrated Device Technology, IDT and the IDT logo are trademarks or registered trademarks of IDT and its subsidiaries in the United States and other countries. Other trademarks used herein are the property of IDT or their respective third party owners.

For datasheet type definitions and a glossary of common terms, visit [www.idt.com/go/glossary](http://www.idt.com/go/glossary).

Copyright ©2016 Integrated Device Technology, Inc. All rights reserved.