



Chipsmall Limited consists of a professional team with an average of over 10 year of expertise in the distribution of electronic components. Based in Hongkong, we have already established firm and mutual-benefit business relationships with customers from,Europe,America and south Asia,supplying obsolete and hard-to-find components to meet their specific needs.

With the principle of “Quality Parts,Customers Priority,Honest Operation,and Considerate Service”,our business mainly focus on the distribution of electronic components. Line cards we deal with include Microchip,ALPS,ROHM,Xilinx,Pulse,ON,Everlight and Freescale. Main products comprise IC,Modules,Potentiometer,IC Socket,Relay,Connector.Our parts cover such applications as commercial,industrial, and automotives areas.

We are looking forward to setting up business relationship with you and hope to provide you with the best service and solution. Let us make a better world for our industry!



Contact us

Tel: +86-755-8981 8866 Fax: +86-755-8427 6832

Email & Skype: info@chipsmall.com Web: www.chipsmall.com

Address: A1208, Overseas Decoration Building, #122 Zhenhua RD., Futian, Shenzhen, China





LOW SKEW, 1-TO-8, CRYSTAL OSCILLATOR/LVCMOS-TO-3.3V, 2.5V LVPECL/LVCMOS FANOUT BUFFER

ICS8538I-26

GENERAL DESCRIPTION



The ICS8538I-26 is a low skew, high performance 1-to-8 Crystal Oscillator/LVCMOS-to-3.3V, 2.5V LVPECL/LVCMOS Fanout Buffer and a member of the HiPerClockSM family of High Performance Clock Solutions from IDT. The ICS8538I-26 has selectable single ended clock or crystal inputs. The single ended clock input accepts LVCMOS or LVTTTL input levels and translate them to 3.3V LVPECL levels. The output enable is internally synchronized to eliminate runt pulses on the outputs during asynchronous assertion/deassertion of the clock enable pin.

Guaranteed output and part-to-part skew characteristics make the ICS8538I-26 ideal for those applications demanding well defined performance and repeatability.

FEATURES

- Two differential 3.3V or 2.5V LVPECL outputs and six single-ended 3.3V or 2.5V LVCMOS/LVTTTL outputs
- Selectable LVCMOS/LVTTTL CLK or crystal inputs
- CLK can accept the following input levels: LVCMOS, LVTTTL
- Maximum output frequency: 266MHz
- Output skew: 60ps (maximum), LVPECL outputs
- Part-to-part skew: 800ps (maximum)
- Propagation delay: 2.05ns (maximum), LVPECL outputs
- Additive phase jitter, RMS: 0.19ps (typical)
- Operating supply modes:
 - LVPECL outputs:**
 - Core/Output 3.3V/3.3V
 - 2.5V/2.5V
 - LVCMOS outputs:**
 - Core/Output 3.3V/3.3V
 - 2.5V/2.5V
- -40°C to 85°C ambient operating temperature
- Available in lead-free (RoHS 6) package

BLOCK DIAGRAM

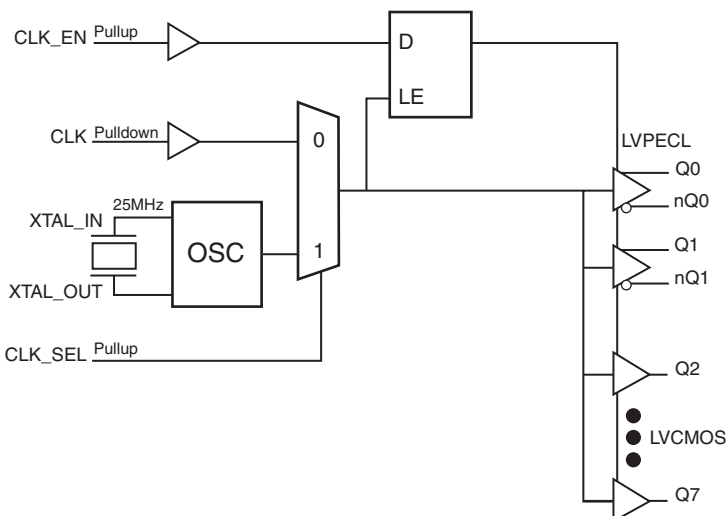

PIN ASSIGNMENT

CLK_EN	1	24	Q7
XTAL_IN	2	23	VCCO_LVCMOS
XTAL_OUT	3	22	Q6
VCC	4	21	VEE
CLK	5	20	Q5
CLK_SEL	6	19	VCCO_LVCMOS
VEE	7	18	Q4
Q0	8	17	VEE
nQ0	9	16	Q3
VCCO_LVPECL	10	15	VCCO_LVCMOS
Q1	11	14	Q2
nQ1	12	13	VEE

ICS8538I-26
24-Lead TSSOP

4.40mm x 7.8mm x 0.925mm package body
G Package
Top View

TABLE 1. PIN DESCRIPTIONS

Number	Name	Type		Description
1	CLK_EN	Input	Pullup	Synchronizing clock enable. When HIGH, clock outputs follow clock input. When LOW, Q outputs are forced low, nQ outputs are forced high. See Table 3B. LVCMOS / LVTTTL interface levels.
2, 3	XTAL_IN, XTAL_OUT	Input		Crystal oscillator interface. XTAL_IN is the input. XTAL_OUT is the output.
4	V _{CC}	Power		Positive supply pin.
5	CLK	Input	Pulldown	Clock input. LVCMOS / LVTTTL interface levels.
6	CLK_SEL	Input	Pullup	Clock select input. When HIGH, selects XTAL inputs. When LOW, selects CLK input. LVCMOS / LVTTTL interface levels.
7, 13, 17, 21	V _{EE}	Power		Negative supply pins.
8, 9	Q0, nQ0	Output		Differential clock outputs. LVPECL interface levels.
10	V _{CCO_LVPECL}	Power		Output power supply mode for LVPECL clock outputs.
11, 12	Q1, nQ1	Output		Differential clock outputs. LVPECL interface levels.
14, 16, 18, 20, 22, 24	Q2, Q3, Q4, Q5, Q6, Q7	Output		Single ended clock outputs. LVCMOS / LVTTTL interface levels.
15, 19, 23	V _{CCO_LVCMOS}	Power		Output power supply mode for LVCMOS / LVTTTL clock outputs.

NOTE: *Pullup* and *Pulldown* refer to internal input resistors. See Table 2, Pin Characteristics, for typical values.

TABLE 2. PIN CHARACTERISTICS

Symbol	Parameter	Test Conditions	Minimum	Typical	Maximum	Units
C _{IN}	Input Capacitance			4		pF
C _{PD}	Power Dissipation Capacitance (per LVCMOS output)	Q2:Q7 V _{CC} , V _{CCO_LVCMOS} = 3.465V		10		pF
		V _{CC} , V _{CCO_LVCMOS} = 2.625V		8		pF
R _{PULLUP}	Input Pullup Resistor			51		kΩ
R _{PULLDOWN}	Input Pulldown Resistor			51		kΩ
R _{OUT}	Output Impedance	Q2:Q7 V _{CCO_LVCMOS} = 3.465V		15		Ω
		V _{CCO_LVCMOS} = 2.625V		20		Ω

TABLE 3A. CONTROL INPUT FUNCTION TABLE

Inputs			Outputs		
CLK_EN	CLK_SEL	Selected Source	Q0, Q1	nQ0, nQ1	Q2:Q7
0	0	CLK	Disabled; LOW	Disabled; HIGH	Disabled; LOW
0	1	XTAL_IN, XTAL_OUT	Disabled; LOW	Disabled; HIGH	Disabled; LOW
1	0	CLK	Enabled	Enabled	Enabled
1	1	XTAL_IN, XTAL_OUT	Enabled	Enabled	Enabled

After CLK_EN switches, the clock outputs are disabled or enabled following a rising and falling input clock or crystal oscillator edge as shown in *Figure 1*.

In the active mode, the state of the outputs are a function of the CLK input as described in Table 3B.

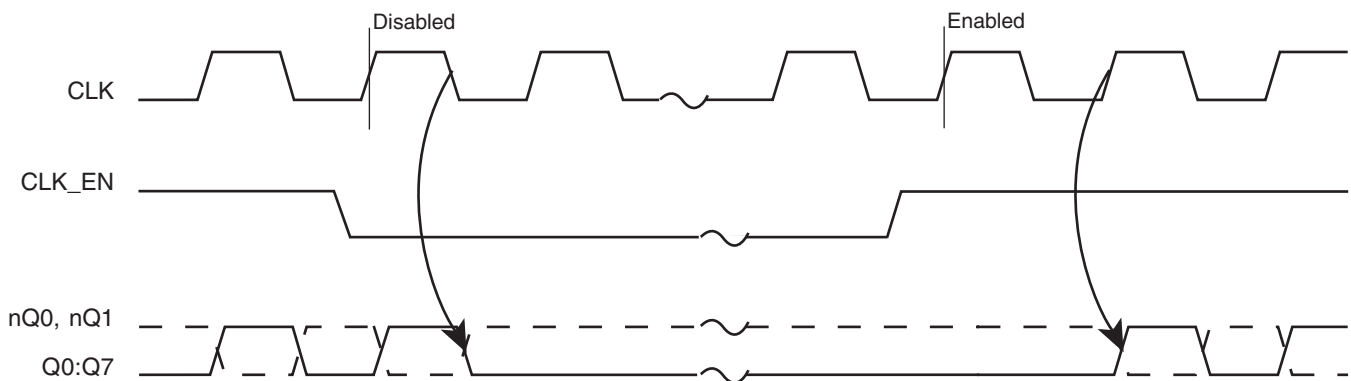

FIGURE 1. CLK_EN TIMING DIAGRAM

TABLE 3B. CLOCK INPUT FUNCTION TABLE

Inputs	Outputs		
CLK	Q0, Q1	nQ0, nQ1	Q2:Q7
0	LOW	HIGH	LOW
1	HIGH	LOW	HIGH

ABSOLUTE MAXIMUM RATINGS

Supply Voltage, V_{CC}	4.6V
Inputs, V_i (LVCMOS)	-0.5V to $V_{CC} + 0.5V$
Outputs, V_o (LVCMOS)	-0.5V to $V_{CCO_LVCMOS} + 0.5V$
Inputs, V_i (LVPECL)	-0.5V to $V_{CC} + 0.5V$
Outputs, I_o (LVPECL)	
Continuous Current	50mA
Surge Current	100mA
Package Thermal Impedance, θ_{JA}	87.8°C/W (0 mps)
Storage Temperature, T_{STG}	-65°C to 150°C

NOTE: Stresses beyond those listed under Absolute Maximum Ratings may cause permanent damage to the device. These ratings are stress specifications only. Functional operation of product at these conditions or any conditions beyond those listed in the *DC Characteristics* or *AC Characteristics* is not implied. Exposure to absolute maximum rating conditions for extended periods may affect product reliability.

TABLE 4A. POWER SUPPLY DC CHARACTERISTICS, $V_{CC} = V_{CCO_LVPECL} = V_{CCO_LVCMOS} = 3.3V \pm 5\%$, $V_{EE} = 0V$, $T_A = -40^\circ C$ TO $85^\circ C$

Symbol	Parameter	Test Conditions	Minimum	Typical	Maximum	Units
V_{CC}	Power Supply Voltage		3.135	3.3	3.465	V
V_{CCO_LVPECL} , V_{CCO_LVCMOS}	Power Supply Voltage		3.135	3.3	3.465	V
I_{EE}	Power Supply Current				60	mA
I_{CCO_LVPECL}	Power Supply Current				12	mA
I_{CCO_LVCMOS}	Power Supply Current				10	mA

TABLE 4B. POWER SUPPLY DC CHARACTERISTICS, $V_{CC} = V_{CCO_LVPECL} = V_{CCO_LVCMOS} = 2.5V \pm 5\%$, $V_{EE} = 0V$, $T_A = -40^\circ C$ TO $85^\circ C$

Symbol	Parameter	Test Conditions	Minimum	Typical	Maximum	Units
V_{CC}	Power Supply Voltage		2.375	2.5	2.625	V
V_{CCO_LVPECL} , V_{CCO_LVCMOS}	Power Supply Voltage		2.375	2.5	2.625	V
I_{EE}	Power Supply Current				60	mA
I_{CCO_LVPECL}	Power Supply Current				12	mA
I_{CCO_LVCMOS}	Power Supply Current				10	mA

TABLE 4C. LVCMOS / LVTTTL DC CHARACTERISTICS, T_A = -40°C TO 85°C

Symbol	Parameter	Test Conditions	Minimum	Typical	Maximum	Units
V _{IH}	Input High Voltage	V _{CC} = 3.3V	2		V _{CC} + 0.3	V
		V _{CC} = 2.5V	1.7		V _{CC} + 0.3	V
V _{IL}	Input Low Voltage	V _{CC} = 3.3V	-0.3		0.8	V
		V _{CC} = 2.5V	-0.3		0.7	V
V _{HYS}	Input Hysteresis	CLK_EN, CLK_SEL	100			mV
I _{IH}	Input High Current	CLK	V _{CC} = V _{IN} = 3.465V or 2.625V		150	μA
		CLK_EN, CLK_SEL	V _{CC} = V _{IN} = 3.465V or 2.625V		5	μA
I _{IL}	Input Low Current	CLK	V _{CC} = 3.465V or 2.625V, V _{IN} = 0V	-5		μA
		CLK_EN, CLK_SEL	V _{CC} = 3.465V or 2.625V, V _{IN} = 0V	-150		μA
V _{OH}	Output High Voltage; NOTE 1	V _{CCO_LVCMOS} = 3.465V	2.6			V
		V _{CCO_LVCMOS} = 2.625V	1.8			V
V _{OL}	Output Low Voltage; NOTE 1	V _{CCO_LVCMOS} = 3.465V or 2.625V			0.5	V

NOTE 1: Outputs terminated with 50Ω to V_{CCO_LVCMOS}/2. See Parameter Measurement Information Section. "LVCMOS Output Load Test circuit" diagrams.

TABLE 4D. LVPECL DC CHARACTERISTICS, V_{CC} = V_{CCO_LVPECL} = 3.3V±5%, V_{EE} = 0V, T_A = -40°C TO 85°C

Symbol	Parameter	Test Conditions	Minimum	Typical	Maximum	Units
V _{OH}	Output High Voltage; NOTE 1		V _{CCO_LVPECL} - 1.4		V _{CCO_LVPECL} - 0.9	V
V _{OL}	Output Low Voltage; NOTE 1		V _{CCO_LVPECL} - 2.0		V _{CCO_LVPECL} - 1.7	V
V _{SWING}	Peak-to-Peak Output Voltage Swing		0.6		1.0	V

NOTE 1: Outputs terminated with 50Ω to V_{CCO_LVPECL} - 2V.

TABLE 4E. LVPECL DC CHARACTERISTICS, V_{CC} = V_{CCO_LVPECL} = 2.5V±5%, V_{EE} = 0V, T_A = -40°C TO 85°C

Symbol	Parameter	Test Conditions	Minimum	Typical	Maximum	Units
V _{OH}	Output High Voltage; NOTE 1		V _{CCO_LVPECL} - 1.4		V _{CCO_LVPECL} - 0.9	V
V _{OL}	Output Low Voltage; NOTE 1		V _{CCO_LVPECL} - 2.0		V _{CCO_LVPECL} - 1.5	V
V _{SWING}	Peak-to-Peak Output Voltage Swing		0.4		1.0	V

NOTE 1: Outputs terminated with 50Ω to V_{CCO_LVPECL} - 2V.

TABLE 5. CRYSTAL CHARACTERISTICS

Parameter	Test Conditions	Minimum	Typical	Maximum	Units
Mode of Oscillation		Fundamental			
Frequency		12		40	MHz
Equivalent Series Resistance (ESR)				50	Ω
Shunt Capacitance				7	pF

TABLE 6A. LVPECL AC CHARACTERISTICS, $V_{CC} = V_{CCO_LVPECL} = 3.3V \pm 5\%$, $V_{EE} = 0V$, $T_A = -40^\circ C$ TO $85^\circ C$

Symbol	Parameter	Test Conditions	Minimum	Typical	Maximum	Units
f_{OUT}	Output Frequency				266	MHz
t_{PD}	Propagation Delay; NOTE 1		1.15		2.05	ns
f_{jit}	Buffer Additive Phase Jitter, RMS; refer to Additive Phase Jitter Section	155.52MHz, (Integration Range: 12kHz - 20MHz)		0.19		ps
$f_{jit}(\emptyset)$	RMS Phase Jitter, Random; NOTE 2	25MHz Crystal, (Integration Range: 1kHz - 1MHz)		0.25		ps
$t_{sk(o)}$	Output Skew; NOTE 3, 5				60	ps
$t_{sk(pp)}$	Part-to-Part Skew; NOTE 4, 5				800	ps
t_R / t_F	Output Rise/Fall Time	20% to 80%	175		925	ps
odc	Output Duty Cycle		45		55	%

NOTE: Electrical parameters are guaranteed over the specified ambient operating temperature range, which is established when the device is mounted in a test socket with maintained transverse airflow greater than 500 lfm. The device will meet specifications after thermal equilibrium has been reached under these conditions.

NOTE: All parameters measured at $f \leq 266MHz$ unless noted otherwise.

NOTE 1: Measured from the $V_{CC}/2$ of the input to the differential output crossing point.

NOTE 2: See phase jitter plot.

NOTE 3: Defined as skew between outputs at the same supply voltage and with equal load conditions.

Measured at the output differential cross points.

NOTE 4: Defined as skew between outputs on different devices operating at the same supply voltages and with equal load conditions. Using the same type of inputs on each device, the outputs are measured at the differential cross points.

NOTE 5: This parameter is defined in accordance with JEDEC Standard 65.

TABLE 6B. LVPECL AC CHARACTERISTICS, $V_{CC} = V_{CCO_LVPECL} = 2.5V \pm 5\%$, $V_{EE} = 0V$, $T_A = -40^\circ C$ TO $85^\circ C$

Symbol	Parameter	Test Conditions	Minimum	Typical	Maximum	Units
f_{OUT}	Output Frequency				266	MHz
t_{PD}	Propagation Delay; NOTE 1		1.15		2.05	ns
f_{jit}	Buffer Additive Phase Jitter, RMS; refer to Additive Phase Jitter Section	155.52MHz, (Integration Range: 12kHz - 20MHz)		0.37		ps
$f_{jit}(\emptyset)$	RMS Phase Jitter, Random; NOTE 2	25MHz Crystal, (Integration Range: 1kHz - 1MHz)		0.27		ps
$t_{sk(o)}$	Output Skew; NOTE 3, 5				60	ps
$t_{sk(pp)}$	Part-to-Part Skew; NOTE 4, 5				800	ps
t_R / t_F	Output Rise/Fall Time	20% to 80%	175		815	ps
odc	Output Duty Cycle		45		55	%

NOTE: Electrical parameters are guaranteed over the specified ambient operating temperature range, which is established when the device is mounted in a test socket with maintained transverse airflow greater than 500 lfm. The device will meet specifications after thermal equilibrium has been reached under these conditions.

NOTE: All parameters measured at $f \leq 266MHz$ unless noted otherwise.

NOTE 1: Measured from the $V_{CC}/2$ of the input to the differential output crossing point.

NOTE 2: See phase jitter plot.

NOTE 3: Defined as skew between outputs at the same supply voltage and with equal load conditions.

Measured at the output differential cross points.

NOTE 4: Defined as skew between outputs on different devices operating at the same supply voltages and with equal load conditions. Using the same type of inputs on each device, the outputs are measured at the differential cross points.

NOTE 5: This parameter is defined in accordance with JEDEC Standard 65.

TABLE 6C. LVCMOS AC CHARACTERISTICS, $V_{CC} = V_{CCO_LVCMOS} = 3.3V \pm 5\%$, $V_{EE} = 0V$, $T_A = -40^\circ C$ TO $85^\circ C$

Symbol	Parameter	Test Conditions	Minimum	Typical	Maximum	Units
f_{OUT}	Output Frequency				266	MHz
t_{PD}	Propagation Delay; NOTE 1		2.5		3.75	ns
f_{jit}	Buffer Additive Phase Jitter, RMS; refer to Additive Phase Jitter Section	155.52MHz, (Integration Range: 12kHz - 20MHz)		0.24		ps
$f_{jit}(\emptyset)$	RMS Phase Jitter, Random; NOTE 2	25MHz Crystal, (Integration Range: 1kHz - 1MHz)		0.25		ps
$t_{sk}(o)$	Output Skew; NOTE 3, 5				112	ps
$t_{sk}(pp)$	Part-to-Part Skew; NOTE 4, 5				800	ps
t_R / t_F	Output Rise/Fall Time	20% to 80%	0.250		1.125	ns
odc	Output Duty Cycle		45		55	%

NOTE: Electrical parameters are guaranteed over the specified ambient operating temperature range, which is established when the device is mounted in a test socket with maintained transverse airflow greater than 500 lfpm. The device will meet specifications after thermal equilibrium has been reached under these conditions.

NOTE: All parameters measured at $f \leq 266\text{MHz}$ unless noted otherwise.

NOTE 1: Measured from the $V_{CC}/2$ of the input to $V_{CCO_LVCMOS}/2$ of the output.

NOTE 2: See phase jitter plot.

NOTE 3: Defined as skew between outputs at the same supply voltage and with equal load conditions.

Measured at $V_{CCO_LVCMOS}/2$.

NOTE 4: Defined as skew between outputs on different devices operating at the same supply voltages and with equal load conditions. Using the same type of inputs on each device, the outputs are measured at $V_{CCO_LVCMOS}/2$.

NOTE 5: This parameter is defined in accordance with JEDEC Standard 65.

TABLE 6D. LVCMOS AC CHARACTERISTICS, $V_{CC} = V_{CCO_LVCMOS} = 2.5V \pm 5\%$, $V_{EE} = 0V$, $T_A = -40^\circ C$ TO $85^\circ C$

Symbol	Parameter	Test Conditions	Minimum	Typical	Maximum	Units
f_{OUT}	Output Frequency				266	MHz
t_{PD}	Propagation Delay; NOTE 1		2.55		4.0	ns
f_{jit}	Buffer Additive Phase Jitter, RMS; refer to Additive Phase Jitter Section	155.52MHz, (Integration Range: 12kHz - 20MHz)		0.22		ps
$f_{jit}(\emptyset)$	RMS Phase Jitter, Random; NOTE 2	25MHz Crystal, (Integration Range: 1kHz - 1MHz)		0.27		ps
$t_{sk}(o)$	Output Skew; NOTE 3, 5				112	ps
$t_{sk}(pp)$	Part-to-Part Skew; NOTE 4, 5				800	ps
t_R / t_F	Output Rise/Fall Time	20% to 80%	0.225		1.45	ns
odc	Output Duty Cycle		40		60	%

NOTE: Electrical parameters are guaranteed over the specified ambient operating temperature range, which is established when the device is mounted in a test socket with maintained transverse airflow greater than 500 lfpm. The device will meet specifications after thermal equilibrium has been reached under these conditions.

NOTE: All parameters measured at $f \leq 266\text{MHz}$ unless noted otherwise.

NOTE 1: Measured from the $V_{CC}/2$ of the input to $V_{CCO_LVCMOS}/2$ of the output.

NOTE 2: See phase jitter plot.

NOTE 3: Defined as skew between outputs at the same supply voltage and with equal load conditions.

Measured at $V_{CCO_LVCMOS}/2$.

NOTE 4: Defined as skew between outputs on different devices operating at the same supply voltages and with equal load conditions. Using the same type of inputs on each device, the outputs are measured at $V_{CCO_LVCMOS}/2$.

NOTE 5: This parameter is defined in accordance with JEDEC Standard 65.

TYPICAL PHASE NOISE AT 100MHz @3.3V

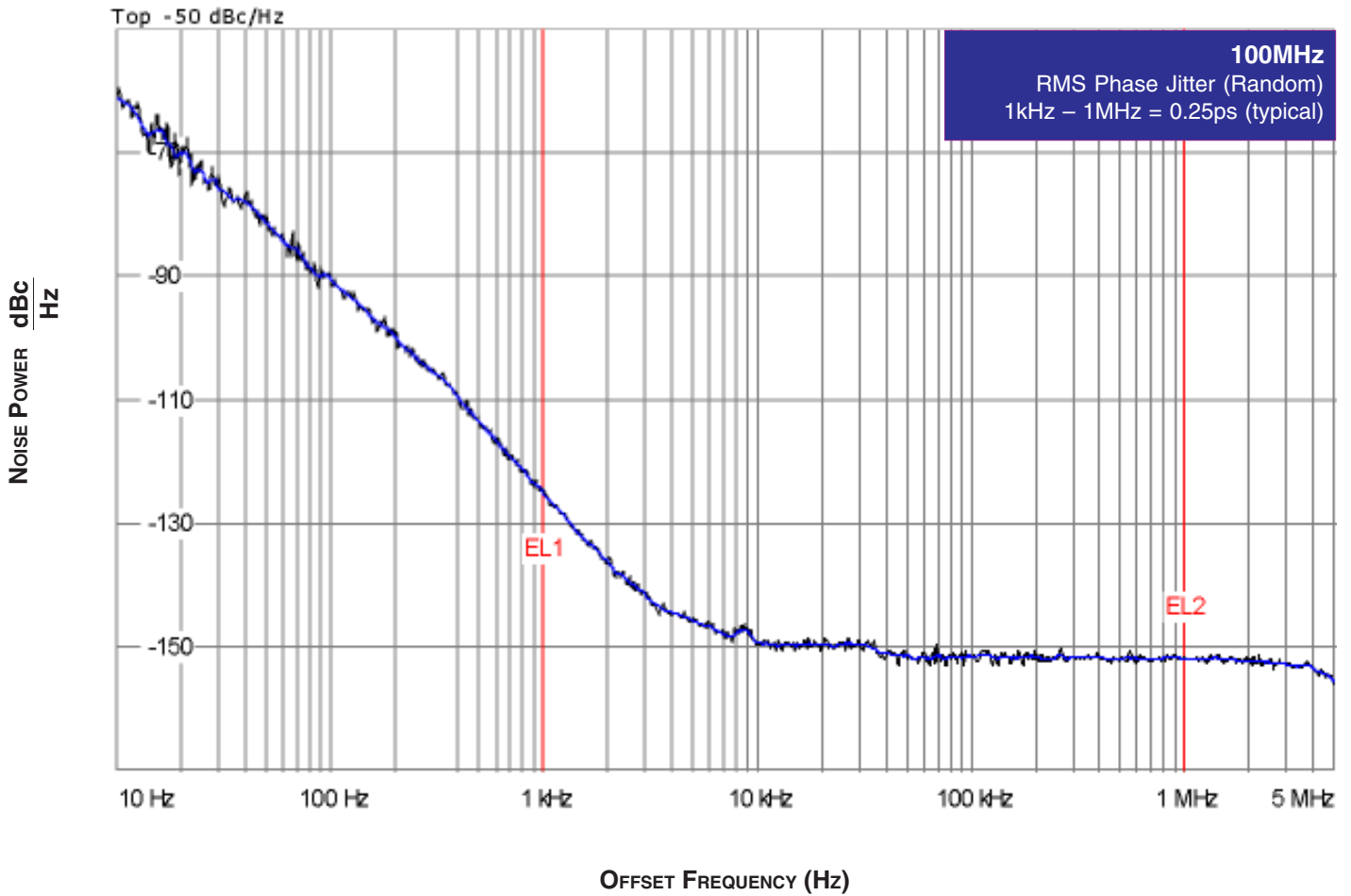

PARAMETER MEASUREMENT INFORMATION

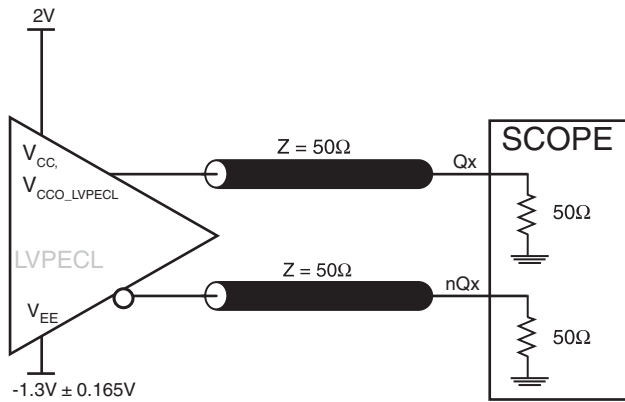

3.3V CORE/3.3V LVPECL OUTPUT LOAD AC TEST CIRCUIT

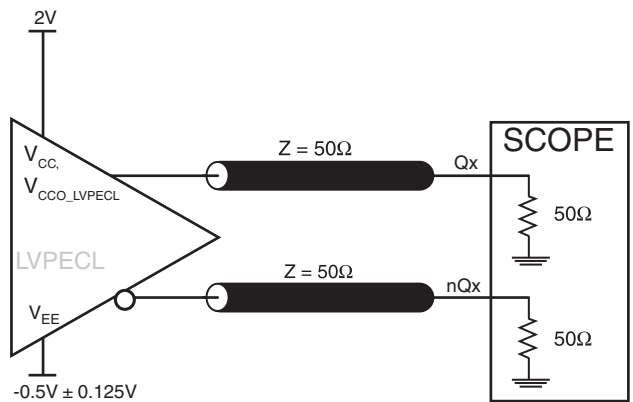

2.5V CORE/ 2.5V LVPECL OUTPUT LOAD AC TEST CIRCUIT

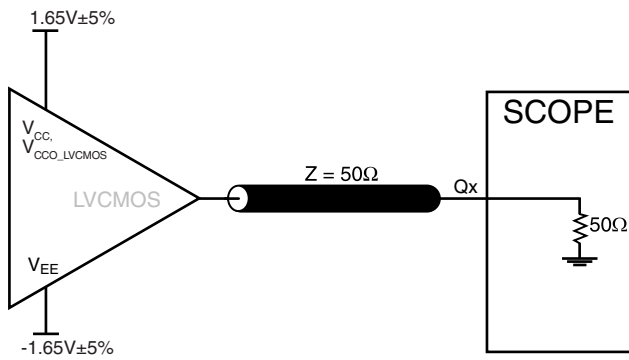

3.3V CORE/3.3V LVCMOS OUTPUT LOAD AC TEST CIRCUIT

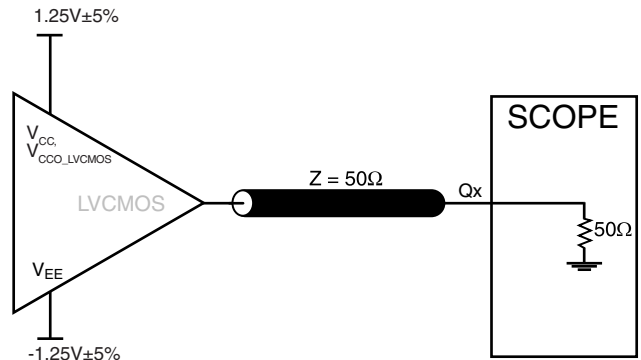

2.5V CORE/ 2.5V LVCMOS OUTPUT LOAD AC TEST CIRCUIT

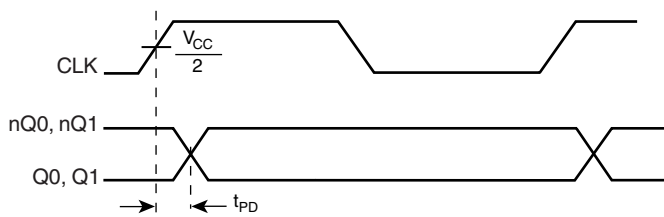

LVPECL PROPAGATION DELAY

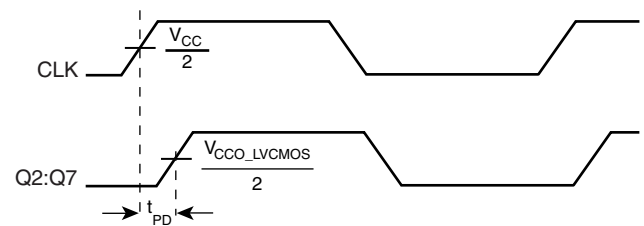

LVCMOS PROPAGATION DELAY

PARAMETER MEASUREMENT INFORMATION, CONTINUED

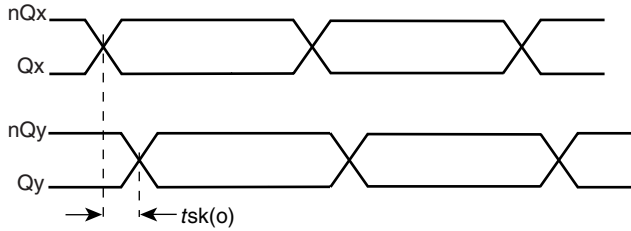

LVPECL OUTPUT SKEW

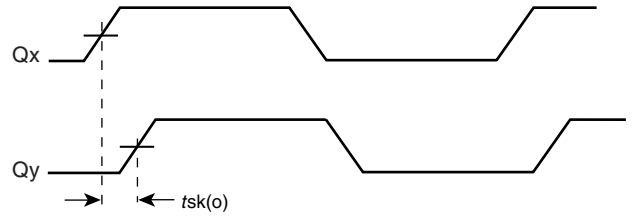

LVCMOS OUTPUT SKEW

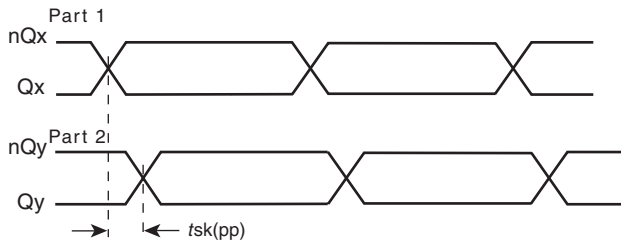

LVPECL PART-TO-PART SKEW

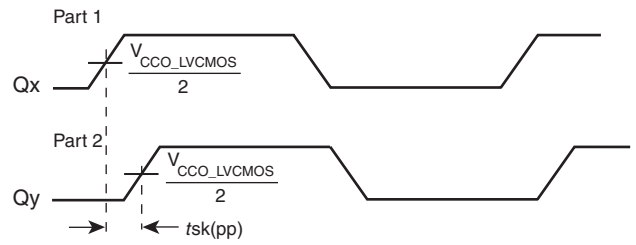

LVCMOS PART-TO-PART SKEW

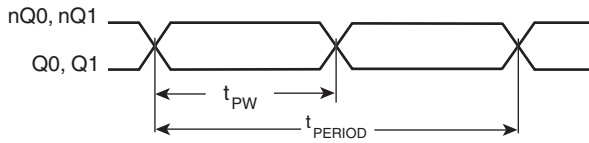

$$\text{odc} = \frac{t_{PW}}{t_{PERIOD}} \times 100\%$$

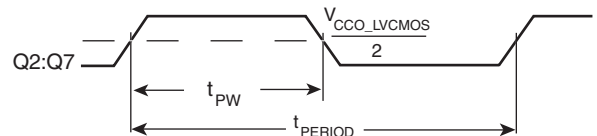

$$\text{odc} = \frac{t_{PW}}{t_{PERIOD}} \times 100\%$$

LVPECL OUTPUT DUTY CYCLE/PULSE WIDTH/PERIOD

LVCMOS OUTPUT DUTY CYCLE/PULSE WIDTH/PERIOD

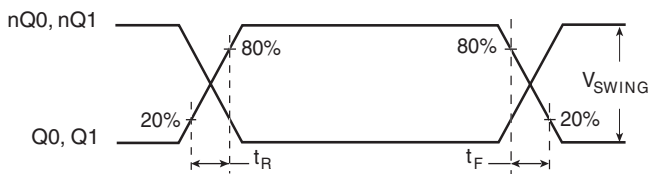

LVPECL OUTPUT RISE/FALL TIME

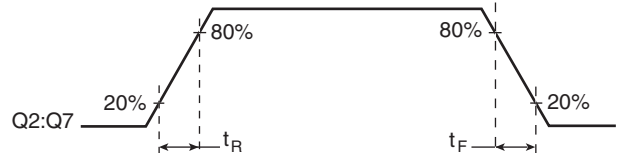

LVCMOS OUTPUT RISE/FALL TIME

PARAMETER MEASUREMENT INFORMATION, CONTINUED

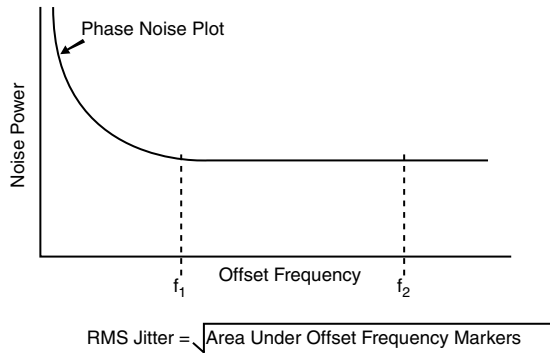

RMS PHASE JITTER

APPLICATION INFORMATION

RECOMMENDATIONS FOR UNUSED INPUT AND OUTPUT PINS

INPUTS:

CRYSTAL INPUTS

For applications not requiring the use of the crystal oscillator input, both XTAL_IN and XTAL_OUT can be left floating. Though not required, but for additional protection, a 1k Ω resistor can be tied from XTAL_IN to ground.

CLK INPUT

For applications not requiring the use of a clock input, it can be left floating. Though not required, but for additional protection, a 1k Ω resistor can be tied from the CLK input to ground.

LVC MOS CONTROL PINS

All control pins have internal pullups or pulldowns; additional resistance is not required but can be added for additional protection. A 1k Ω resistor can be used.

OUTPUTS:

LVC MOS OUTPUTS

All unused LVC MOS output can be left floating. There should be no trace attached.

LVPECL OUTPUTS

All unused LVPECL outputs can be left floating. We recommend that there is no trace attached. Both sides of the differential output pair should either be left floating or terminated.

CRYSTAL INPUT INTERFACE

The ICS8538I-26 has been characterized with 18pF parallel resonant crystals. The capacitor values, C1 and C2, shown in *Figure 2* below were determined using an 18pF parallel resonant crystal and were chosen to minimize the ppm error. These same

capacitor values will tune any 18pF parallel resonant crystal over the frequency range and other parameters specified in this data sheet. The optimum C1 and C2 values can be slightly adjusted for different board layouts.

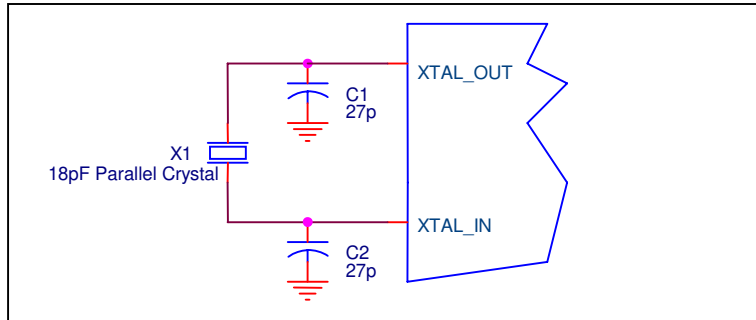

FIGURE 2. CRYSTAL INPUT INTERFACE

LVC MOS TO XTAL INTERFACE

The XTAL_IN input can accept a single-ended LVC MOS signal through an AC coupling capacitor. A general interface diagram is shown in *Figure 3*. The XTAL_OUT pin can be left floating. The input edge rate can be as slow as 10ns. For LVC MOS signals, it is recommended that the amplitude be reduced from full swing to half swing in order to prevent signal interference with the power rail and to reduce noise. This configuration requires that the output

impedance of the driver (R_o) plus the series resistance (R_s) equals the transmission line impedance. In addition, matched termination at the crystal input will attenuate the signal in half. This can be done in one of two ways. First, R_1 and R_2 in parallel should equal the transmission line impedance. For most 50 Ω applications, R_1 and R_2 can be 100 Ω . This can also be accomplished by removing R_1 and making R_2 50 Ω .

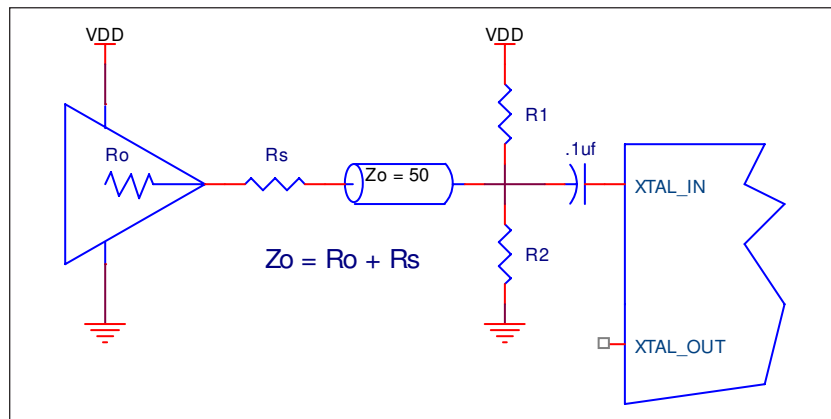

FIGURE 3. GENERAL DIAGRAM FOR LVC MOS DRIVER TO XTAL INPUT INTERFACE

TERMINATION FOR 3.3V LVPECL OUTPUTS

The clock layout topology shown below is a typical termination for LVPECL outputs. The two different layouts mentioned are recommended only as guidelines.

FOUT and nFOUT are low impedance follower outputs that generate ECL/LVPECL compatible outputs. Therefore, terminating resistors (DC current path to ground) or current sources must be used for functionality. These outputs are designed to

drive 50Ω transmission lines. Matched impedance techniques should be used to maximize operating frequency and minimize signal distortion. *Figures 4A and 4B* show two different layouts which are recommended only as guidelines. Other suitable clock layouts may exist and it would be recommended that the board designers simulate to guarantee compatibility across all printed circuit and clock component process variations.

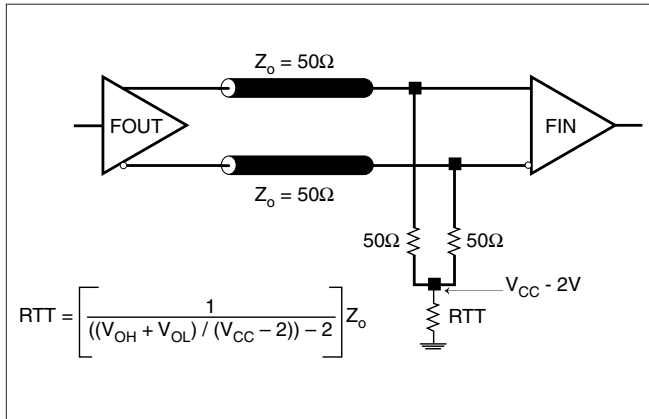

FIGURE 4A. LVPECL OUTPUT TERMINATION

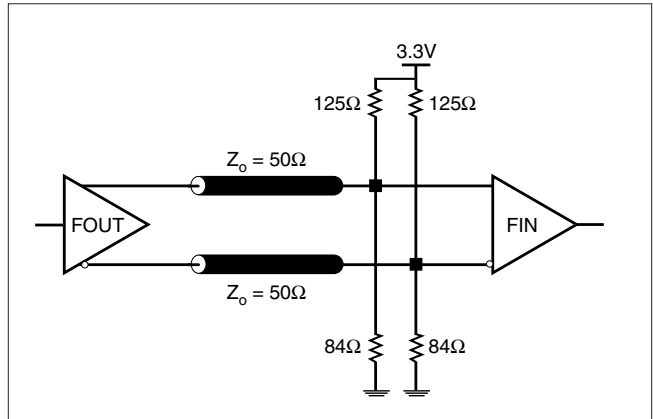

FIGURE 4B. LVPECL OUTPUT TERMINATION

TERMINATION FOR 2.5V LVPECL OUTPUTS

Figure 5A and Figure 5B show examples of termination for 2.5V LVPECL driver. These terminations are equivalent to terminating 50Ω to $V_{CC} - 2V$. For $V_{CC} = 2.5V$, the $V_{CC} - 2V$ is

very close to $_LVCMOS$ ground level. The R3 in Figure 5B can be eliminated and the termination is shown in Figure 5C.

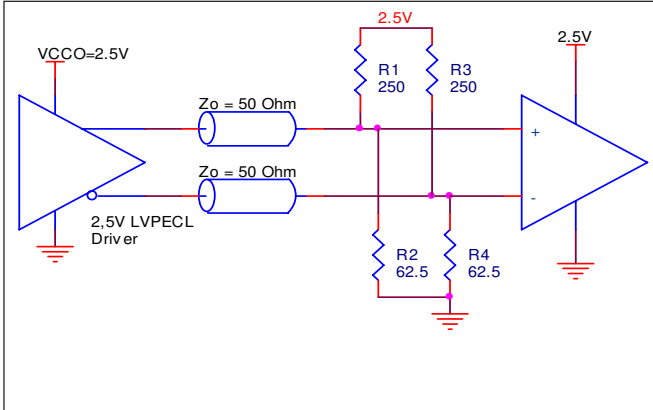

FIGURE 5A. 2.5V LVPECL DRIVER TERMINATION EXAMPLE

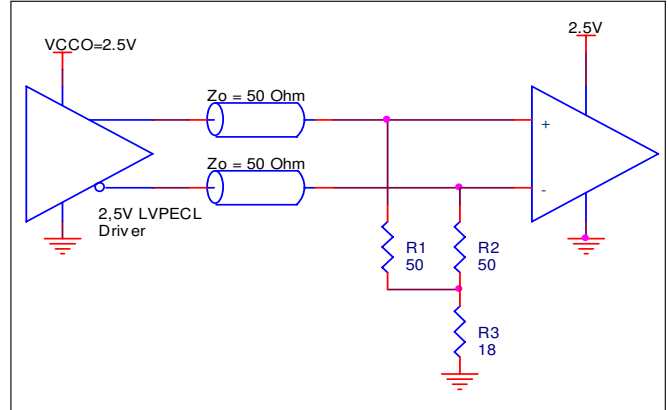

FIGURE 5B. 2.5V LVPECL DRIVER TERMINATION EXAMPLE

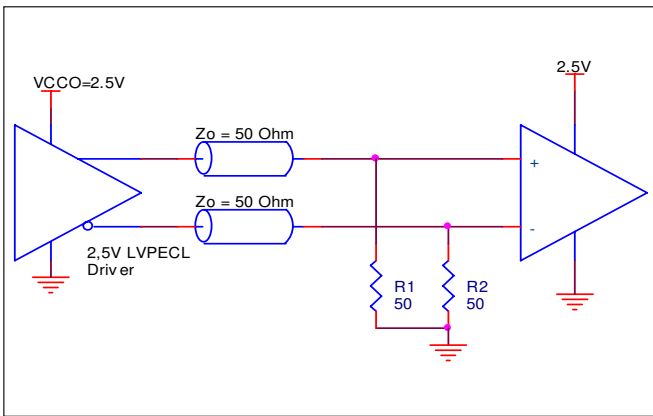

FIGURE 5C. 2.5V LVPECL TERMINATION EXAMPLE

POWER CONSIDERATIONS

This section provides information on power dissipation and junction temperature for the ICS8538I-26. Equations and example calculations are also provided.

1. Power Dissipation.

The total power dissipation for the ICS8538I-26 is the sum of the core power plus the power dissipated in the load(s). The following is the power dissipation for $V_{CC} = 3.3V + 5\% = 3.465V$, which gives worst case results.

NOTE: Please refer to Section 3 for details on calculating power dissipated in the load.

Core and LVPECL Output Power Dissipation

- Power (core)_{MAX} = $V_{CC_MAX} * I_{EE_MAX} = 3.465V * 60mA = 207.9mW$
- Power (outputs)_{MAX} = **30mW/Loaded Output pair**
If all outputs are loaded, the total power is $2 * 30mW = 60mW$

LVC MOS Output Power Dissipation

- Output Impedance R_{OUT} Power Dissipation due to Loading 50Ω to $V_{CCO_LVCMOS}/2$
Output Current $I_{OUT} = V_{CCO_MAX} / [2 * (50\Omega + R_{OUT})] = 3.465V / [2 * (50\Omega + 15\Omega)] = 26.7mA$
- Power Dissipation on the R_{OUT} per LVCMOS output
Power (R_{OUT}) = $R_{OUT} * (I_{OUT})^2 = 15\Omega * (26.7mA)^2 = 10.7mW$ per output
- Total Power Dissipation on the R_{OUT}
Total Power (R_{OUT}) = $10.7mW * 6 = 64.2mW$
- Dynamic Power Dissipation at 25MHz
Power (25MHz) = $C_{PD} * Frequency * (V_{CCO_LVCMOS})^2 = 10pF * 25MHz * (3.465V)^2 = 3mW$ per output
Total Power (25MHz) = $3mW * 6 = 18mW$

Total Power Dissipation

- **Total Power**
= Power (core) + Power (LVPECL output) + Total Power (R_{OUT}) + Total Power (25MHz)
= $207.9mW + 60mW + 64.2mW + 18mW$
= **350.1mW**

2. Junction Temperature.

Junction temperature, T_j, is the temperature at the junction of the bond wire and bond pad and directly affects the reliability of the device. The maximum recommended junction temperature for HiPerClockS™ devices is 125°C.

The equation for T_j is as follows: $T_j = \theta_{JA} * Pd_{total} + T_A$

T_j = Junction Temperature

θ_{JA} = Junction-to-Ambient Thermal Resistance

Pd_{total} = Total Device Power Dissipation (example calculation is in section 1 above)

T_A = Ambient Temperature

In order to calculate junction temperature, the appropriate junction-to-ambient thermal resistance θ_{JA} must be used. Assuming no air flow and a multi-layer board, the appropriate value is 87.8°C/W per Table 7 below.

Therefore, T_j for an ambient temperature of 85°C with all outputs switching is:
 $85^\circ\text{C} + 0.350\text{W} * 87.8^\circ\text{C}/\text{W} = 115.7^\circ\text{C}$. This is below the limit of 125°C.

This calculation is only an example. T_j will obviously vary depending on the number of loaded outputs, supply voltage, air flow, and the type of board (multi-layer).

TABLE 7. THERMAL RESISTANCE θ_{JA} FOR 24-PIN TSSOP, FORCED CONVECTION

θ_{JA} by Velocity (Meters per Second)			
	0	1	2.5
Multi-Layer PCB, JEDEC Standard Test Boards	87.8°C/W	83.5°C/W	81.3°C/W

3. Calculations and Equations.

The purpose of this section is to derive the power dissipated into the load.

LVPECL output driver circuit and termination are shown in *Figure 5*.

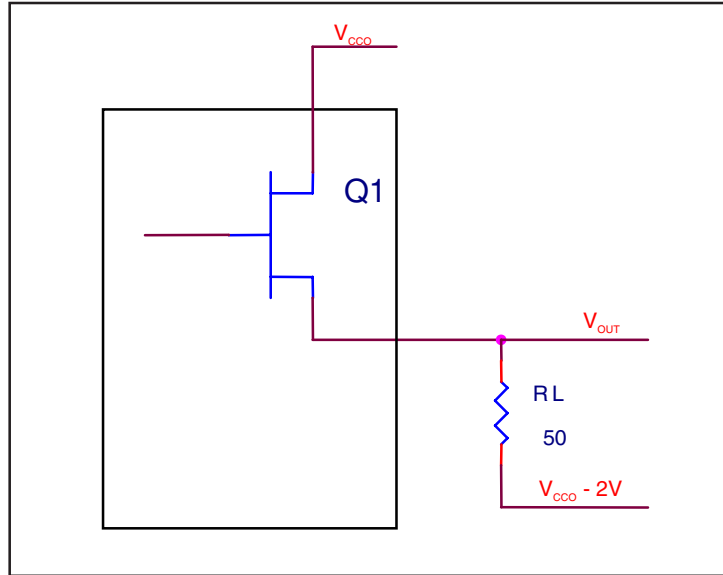

FIGURE 5. LVPECL DRIVER CIRCUIT AND TERMINATION

To calculate worst case power dissipation into the load, use the following equations which assume a 50Ω load, and a termination voltage of $V_{cco} - 2V$.

- For logic high, $V_{OUT} = V_{OH_MAX} = V_{CCO_MAX} - 0.9V$
 $(V_{CCO_MAX} - V_{OH_MAX}) = 0.9V$
- For logic low, $V_{OUT} = V_{OL_MAX} = V_{CCO_MAX} - 1.7V$
 $(V_{CCO_MAX} - V_{OL_MAX}) = 1.7V$

Pd_H is power dissipation when the output drives high.
 Pd_L is the power dissipation when the output drives low.

$$Pd_H = [(V_{OH_MAX} - (V_{CCO_MAX} - 2V))/R_L] * (V_{CCO_MAX} - V_{OH_MAX}) = [(2V - (V_{CCO_MAX} - V_{OH_MAX}))/R_L] * (V_{CCO_MAX} - V_{OH_MAX}) = [(2V - 0.9V)/50\Omega] * 0.9V = \mathbf{19.8mW}$$

$$Pd_L = [(V_{OL_MAX} - (V_{CCO_MAX} - 2V))/R_L] * (V_{CCO_MAX} - V_{OL_MAX}) = [(2V - (V_{CCO_MAX} - V_{OL_MAX}))/R_L] * (V_{CCO_MAX} - V_{OL_MAX}) = [(2V - 1.7V)/50\Omega] * 1.7V = \mathbf{10.2mW}$$

Total Power Dissipation per output pair = Pd_H + Pd_L = **30mW**

RELIABILITY INFORMATION

TABLE 8. θ_{JA} vs. AIR FLOW TABLE FOR 24 LEAD TSSOP

θ_{JA} by Velocity (Meters per Second)			
	0	1	2.5
Multi-Layer PCB, JEDEC Standard Test Boards	87.8°C/W	83.5°C/W	81.3°C/W

TRANSISTOR COUNT

The transistor count for ICS8538I-26 is: 726

PACKAGE OUTLINE AND PACKAGE DIMENSIONS

PACKAGE OUTLINE - G SUFFIX FOR 24 LEAD TSSOP

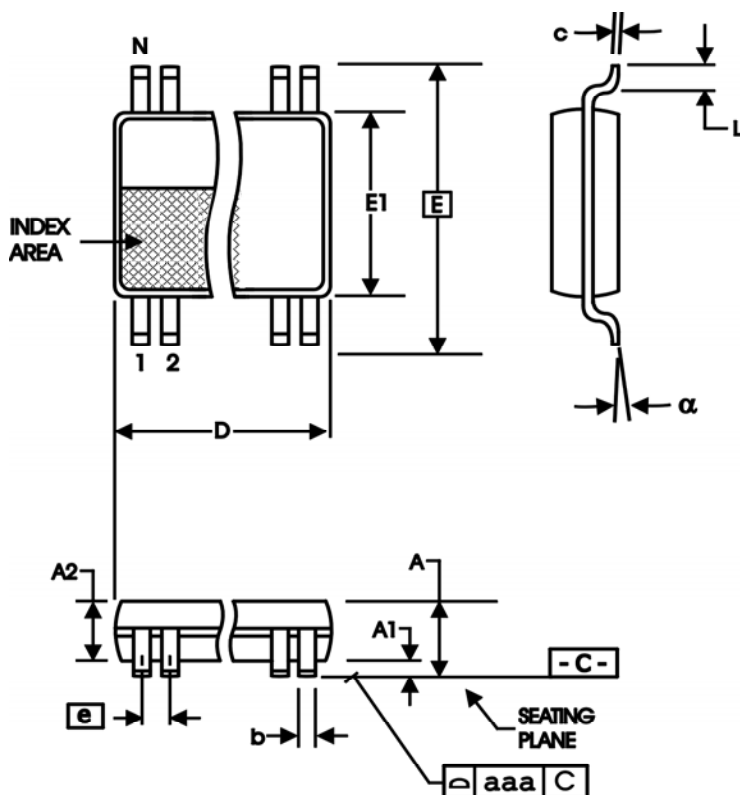

TABLE 9. PACKAGE DIMENSIONS

SYMBOL	Millimeters	
	Minimum	Maximum
N	24	
A	--	1.20
A1	0.05	0.15
A2	0.80	1.05
b	0.19	0.30
c	0.09	0.20
D	7.70	7.90
E	6.40 BASIC	
E1	4.30	4.50
e	0.65 BASIC	
L	0.45	0.75
alpha	0°	8°
aaa	--	0.10

Reference Document: JEDEC Publication 95, MO-153

TABLE 10. ORDERING INFORMATION

Part/Order Number	Marking	Package	Shipping Packaging	Temperature
8538BGI-26LF	8538BGI26L	24 lead "Lead-Free" TSSOP	tube	-40°C to 85°C
8538BGI-26LFT	8538BGI26L	24 lead "Lead-Free" TSSOP	2500 tape & reel	-40°C to 85°C

NOTE: Parts that are ordered with an "LF" suffix to the part number are the Pb-Free configuration and are RoHS compliant.

While the information presented herein has been checked for both accuracy and reliability, Integrated Device Technology, Incorporated (IDT) assumes no responsibility for either its use or for infringement of any patents or other rights of third parties, which would result from its use. No other circuits, patents, or licenses are implied. This product is intended for use in normal commercial and industrial applications. Any other applications such as those requiring high reliability or other extraordinary environmental requirements are not recommended without additional processing by IDT. IDT reserves the right to change any circuitry or specifications without notice. IDT does not authorize or warrant any IDT product for use in life support devices or critical medical instruments.

REVISION HISTORY SHEET

Rev	Table	Page	Description of Change	Date
B		1	Features section - LVPECL operating supply modes, added full 2.5; for LVC MOS outputs, changed 3.3V/2.5V to full 2.5V mode.	4/14/09
	T2	2	Pin Characteristics - updated table to accommodate 2.5V for C _{PD} and R _{OUT} and added specs.	
	T4A - T4B	4	Power Supply Table - updated power supply tables to new supply mode.	
	T4C	5	LVC MOS Table - updated table with new supply mode.	
	T5E	5	Added 2.5V LVPECL DC Characteristics Table.	
	T6B	6	Added 2.5V LVPECL AC Characteristics Table.	
	T6C	7	Added 3.3V LVC MOS AC Characteristics Table.	
	T6D	7	Changed LVC MOS AC Characteristics Table from 3.3V/2.5V to 2.5V/2.5V.	
		8	Added RMS Phase Jitter Plot.	
		11	Parameter Measurement Information Section - added RMS Phase Jitter diagram.	
	T7	16	Recalculated junction temperature equation and updated Thermal Resistance table.	
T8	18	Updated Thermal Resistance Table.		

Innovate with IDT and accelerate your future networks. Contact:

www.IDT.com

For Sales

800-345-7015 (inside USA)
+408-284-8200 (outside USA)
Fax: 408-284-2775
www.IDT.com/go/contactIDT

For Tech Support

netcom@idt.com
+480-763-2056

Corporate Headquarters

Integrated Device Technology, Inc.
6024 Silver Creek Valley Road
San Jose, CA 95138
United States
800-345-7015 (inside USA)
+408-284-8200 (outside USA)

