



Chipsmall Limited consists of a professional team with an average of over 10 year of expertise in the distribution of electronic components. Based in Hongkong, we have already established firm and mutual-benefit business relationships with customers from,Europe,America and south Asia,supplying obsolete and hard-to-find components to meet their specific needs.

With the principle of “Quality Parts,Customers Priority,Honest Operation,and Considerate Service”,our business mainly focus on the distribution of electronic components. Line cards we deal with include Microchip,ALPS,ROHM,Xilinx,Pulse,ON,Everlight and Freescale. Main products comprise IC,Modules,Potentiometer,IC Socket,Relay,Connector.Our parts cover such applications as commercial,industrial, and automotives areas.

We are looking forward to setting up business relationship with you and hope to provide you with the best service and solution. Let us make a better world for our industry!



## Contact us

Tel: +86-755-8981 8866 Fax: +86-755-8427 6832

Email & Skype: info@chipsmall.com Web: www.chipsmall.com

Address: A1208, Overseas Decoration Building, #122 Zhenhua RD., Futian, Shenzhen, China



## General Description

The 853S011B is a low skew, high performance 1-to-2 Differential-to-2.5V/3.3V LVPECL/ECL Fanout Buffer. The 853S011B is characterized to operate from either a 2.5V or a 3.3V power supply. Guaranteed output and part-to-part skew characteristics make the 853S011B ideal for those clock distribution applications demanding well defined performance and repeatability.

## Features

- Two differential 2.5V, 3.3V LVPECL/ECL outputs
- One differential PCLK, nPCLK input pair
- PCLK, nPCLK pairs can accept the following differential input levels: LVPECL, LVDS, CML, SSTL
- Maximum output frequency: >2.5GHz
- Translates any single-ended input signal to 3.3V LVPECL levels with resistor bias on nPCLK input
- Output skew: 5ps (typical)
- Part-to-part skew: 130ps (maximum)
- Propagation delay: 355ps (maximum)
- LVPECL mode operating voltage supply range:  $V_{CC} = 2.375V$  to  $3.8V$ ,  $V_{EE} = 0V$
- ECL mode operating voltage supply range:  $V_{CC} = 0V$ ,  $V_{EE} = -3.8V$  to  $-2.375V$
- $-40^{\circ}C$  to  $85^{\circ}C$  ambient operating temperature
- Available lead-free (RoHS 6) package

## Block Diagram

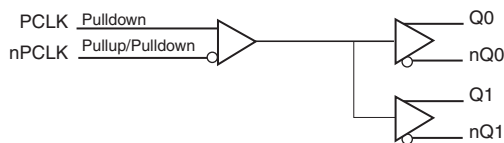

## Pin Assignment

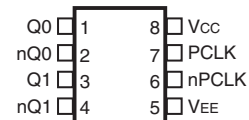

### 853S011B

**8-Lead SOIC, 150MIL**

**3.90mm x 4.90mm x 1.37mm package body**

**M Package**

**Top View**

**8-Lead TSSOP, 118MIL**

**3.0mm x 3.0mm x 0.97mm package body**

**G Package**

**Top View**

## Pin Description and Pin Characteristic Tables

**Table 1. Pin Descriptions**

Number	Name	Type		Description
1, 2	Q0, nQ0	Output		Differential output pair. LVPECL/ECL interface levels.
3, 4	Q1, nQ1	Output		Differential output pair. LVPECL/ECL interface levels.
5	V <sub>EE</sub>	Power		Negative supply pin.
6	nPCLK	Input	Pullup/ Pulldown	Inverting differential LVPECL clock input. V <sub>CC</sub> /2 default when left floating.
7	PCLK	Input	Pulldown	Non-inverting differential LVPECL clock input.
8	V <sub>CC</sub>	Power		Positive supply pin.

NOTE: *Pullup* and *Pulldown* refer to internal input resistors. See Table 2, *Pin Characteristics*, for typical values.

**Table 2. Pin Characteristics**

Symbol	Parameter	Test Conditions	Minimum	Typical	Maximum	Units
R <sub>PULLDOWN</sub>	Input Pulldown Resistor			75		kΩ
R <sub>VCC/2</sub>	RPullup/Pulldown Resistors			50		kΩ

## Absolute Maximum Ratings

NOTE: Stresses beyond those listed under *Absolute Maximum Ratings* may cause permanent damage to the device. These ratings are stress specifications only. Functional operation of product at these conditions or any conditions beyond those listed in the *DC Characteristics* or *AC Characteristics* is not implied. Exposure to absolute maximum rating conditions for extended periods may affect product reliability.

Item	Rating
Supply Voltage, $V_{CC}$	4.6V (LVPECL mode, $V_{EE} = 0V$ )
Negative Supply Voltage, $V_{EE}$	-4.6V (ECL mode, $V_{CC} = 0V$ )
Inputs, $V_I$ (LVPECL mode)	-0.5V to $V_{CC} + 0.5V$
Inputs, $V_I$ (ECL mode)	0.5V to $V_{EE} - 0.5V$
Outputs, $I_O$ Continuous Current Surge Current	50mA 100mA
Operating Temperature Range, $T_A$	-40°C to +85°C
Package Thermal Impedance, $\theta_{JA}$ (Junction-to-Ambient) for 8 Lead SOIC	102°C/W (0 mps)
Package Thermal Impedance, $\theta_{JA}$ (Junction-to-Ambient) for 8 Lead TSSOP	145.4°C/W (0 mps)
Storage Temperature, $T_{STG}$	-65°C to 150°C

## DC Electrical Characteristics

**Table 3A. Power Supply DC Characteristics,  $V_{CC} = V_{CCO} = 2.375V$  to  $3.8V$ ;  $V_{EE} = 0V$ ,  $T_A = -40^\circ C$  to  $85^\circ C$**

Symbol	Parameter	Test Conditions	Minimum	Typical	Maximum	Units
$V_{CC}$	Positive Supply Voltage		2.375	3.3	3.8	V
$I_{EE}$	Power Supply Current				25	mA

**Table 3B. LVPECL DC Characteristics,  $V_{CC} = 3.3V$ ;  $V_{EE} = 0V$ ,  $T_A = -40^{\circ}C$  to  $85^{\circ}C$** 

Symbol	Parameter		$-40^{\circ}C$			$25^{\circ}C$			$85^{\circ}C$			Units
			Min	Typ	Max	Min	Typ	Max	Min	Typ	Max	
$V_{OH}$	Output High Voltage; NOTE 1		2.245	2.350	2.450	2.265	2.340	2.415	2.245	2.320	2.395	V
$V_{OL}$	Output Low Voltage; NOTE 1		1.380	1.520	1.660	1.415	1.510	1.605	1.405	1.500	1.595	V
$V_{PP}$	Peak-to-Peak Input Voltage		150	800	1200	150	800	1200	150	800	1200	mV
$V_{CMR}$	Input High Voltage Common Mode Range; NOTE 2		1.2		3.3	1.2		3.3	1.2		3.3	V
$I_{IH}$	Input High Current	PCLK, nPCLK			200			200			200	$\mu A$
$I_{IL}$	Input Low Current	PCLK	-10			-10			-10			$\mu A$
		nPCLK	-200			-200			-200			$\mu A$

NOTE: Electrical parameters are guaranteed over the specified ambient operating temperature range, which is established when the device is mounted in a test socket with maintained transverse airflow greater than 500 lfm. The device will meet specifications after thermal equilibrium has been reached under these conditions.

NOTE: Input and output parameters vary 1:1 with  $V_{CC}$ .  $V_{EE}$  can vary +0.925V to -0.5V.

NOTE 1: Outputs terminated with  $50\Omega$  to  $V_{CC0} - 2V$ .

NOTE 2: Common mode voltage is defined as  $V_{IH}$ .

**Table 3C. LVPECL DC Characteristics,  $V_{CC} = 2.5V$ ;  $V_{EE} = 0V$ ,  $T_A = -40^{\circ}C$  to  $85^{\circ}C$** 

Symbol	Parameter		$-40^{\circ}C$			$25^{\circ}C$			$85^{\circ}C$			Units
			Min	Typ	Max	Min	Typ	Max	Min	Typ	Max	
$V_{OH}$	Output High Voltage; NOTE 1		1.445	1.550	1.650	1.405	1.540	1.615	1.445	1.520	1.595	V
$V_{OL}$	Output Low Voltage; NOTE 1		0.580	0.720	0.860	0.615	0.710	0.805	0.605	0.700	0.795	V
$V_{PP}$	Peak-to-Peak Input Voltage		150	800	1200	150	800	1200	150	800	1200	mV
$V_{CMR}$	Input High Voltage Common Mode Range; NOTE 2		1.2		2.5	1.2		2.5	1.2		2.5	V
$I_{IH}$	Input High Current	PCLK, nPCLK			200			200			200	$\mu A$
$I_{IL}$	Input Low Current	PCLK	-10			-10			-10			$\mu A$
		nPCLK	-200			-200			-200			$\mu A$

NOTE: Electrical parameters are guaranteed over the specified ambient operating temperature range, which is established when the device is mounted in a test socket with maintained transverse airflow greater than 500 lfm. The device will meet specifications after thermal equilibrium has been reached under these conditions.

NOTE: Input and output parameters vary 1:1 with  $V_{CC}$ .  $V_{EE}$  can vary +0.925V to -0.5V.

NOTE 1: Outputs terminated with  $50\Omega$  to  $V_{CC0} - 2V$ .

NOTE 2: Common mode voltage is defined as  $V_{IH}$ .

**Table 3D. ECL DC Characteristics,  $V_{CC} = 0V$ ;  $V_{EE} = -3.8V$  to  $-2.375V$ ,  $T_A = -40^{\circ}C$  to  $85^{\circ}C$** 

Symbol	Parameter	$-40^{\circ}C$			$25^{\circ}C$			$85^{\circ}C$			Units
		Min	Typ	Max	Min	Typ	Max	Min	Typ	Max	
$V_{OH}$	Output High Voltage; NOTE 1	-1.055	-0.950	-0.850	-1.035	-0.960	-0.885	-1.055	-0.980	0.905	V
$V_{OL}$	Output Low Voltage; NOTE 1	-1.920	-1.780	-1.640	-1.885	-1.790	-1.695	-1.895	-1.800	-1.705	V
$V_{PP}$	Peak-to-Peak Input Voltage	150	800	1200	150	800	1200	150	800	1200	mV
$V_{CMR}$	Input High Voltage Common Mode Range; NOTE 2	$V_{EE}+1.2$		0	$V_{EE}+1.2$		0	$V_{EE}+1.2$		0	V
$I_{IH}$	Input High Current	PCLK, nPCLK		200			200			200	$\mu A$
$I_{IL}$	Input Low Current	PCLK	-10		-10			-10			$\mu A$
		nPCLK	-200		-200			-200			$\mu A$

NOTE: Input and output parameters vary 1:1 with  $V_{CC}$ .  $V_{EE}$  can vary  $+0.925V$  to  $-0.5V$ .

NOTE 1: Outputs terminated with  $50\Omega$  to  $V_{CCO} - 2V$ .

NOTE 2: Common mode voltage is defined as  $V_{IH}$ .

## AC Electrical Characteristics

**Table 4. AC Characteristics,  $V_{CC} = -3.8V$  to  $-2.375V$  or ,  $V_{CC} = V_{CCO} = 2.375V$  to  $3.8V$ ;  $V_{EE} = 0V$ ,  $T_A = -40^{\circ}C$  to  $85^{\circ}C$**

Symbol	Parameter		$-40^{\circ}C$			$25^{\circ}C$			$85^{\circ}C$			Units
			Min	Typ	Max	Min	Typ	Max	Min	Typ	Max	
$f_{MAX}$	Output Frequency				>2.5			>2.5			>2.5	GHz
$t_{PD}$	Propagation Delay; NOTE 1		195		330	210		340	215		355	ps
$t_{sk(o)}$	Output Skew; NOTE 2, 4			5	20		5	20	5		20	ps
$t_{sk(pp)}$	Part-to-Part Skew; NOTE 3, 4				130			130			130	ps
$f_{jit}$	Buffer Additive Phase Jitter, RMS; refer to Additive Phase Jitter Section			0.026			0.026			0.026		ps
$t_R / t_F$	Output Rise/Fall Time	20% to 80%	70		250	80		250	90		250	ps
odc	Output Duty Cycle; $f \leq 750MHz$		48	50	52	48	50	52	48	50	52	%

NOTE: Electrical parameters are guaranteed over the specified ambient operating temperature range, which is established when the device is mounted in a test socket with maintained transverse airflow greater than 500 lfm. The device will meet specifications after thermal equilibrium has been reached under these conditions.

NOTE: All parameters are measured at  $f \leq 1.7GHz$ , unless otherwise noted.

NOTE 1: Measured from the differential input crossing point to the differential output crossing point.

NOTE 2: Defined as skew between outputs at the same supply voltage and with equal load conditions. Measured at the output differential cross points.

NOTE 3: Defined as skew between outputs on different devices operating at the same supply voltages and with equal load conditions. Using the same type of inputs on each device, the outputs are measured at the differential cross points.

NOTE 4: This parameter is defined in accordance with JEDEC Standard 65.

## Additive Phase Jitter

The spectral purity in a band at a specific offset from the fundamental compared to the power of the fundamental is called the **dBc Phase Noise**. This value is normally expressed using a Phase noise plot and is most often the specified plot in many applications. Phase noise is defined as the ratio of the noise power present in a 1Hz band at a specified offset from the fundamental frequency to the power value of the fundamental. This ratio is expressed in decibels (dBm) or a ratio

of the power in the 1Hz band to the power in the fundamental. When the required offset is specified, the phase noise is called a **dBc** value, which simply means dBm at a specified offset from the fundamental. By investigating jitter in the frequency domain, we get a better understanding of its effects on the desired application over the entire time record of the signal. It is mathematically possible to calculate an expected bit error rate given a phase noise plot.

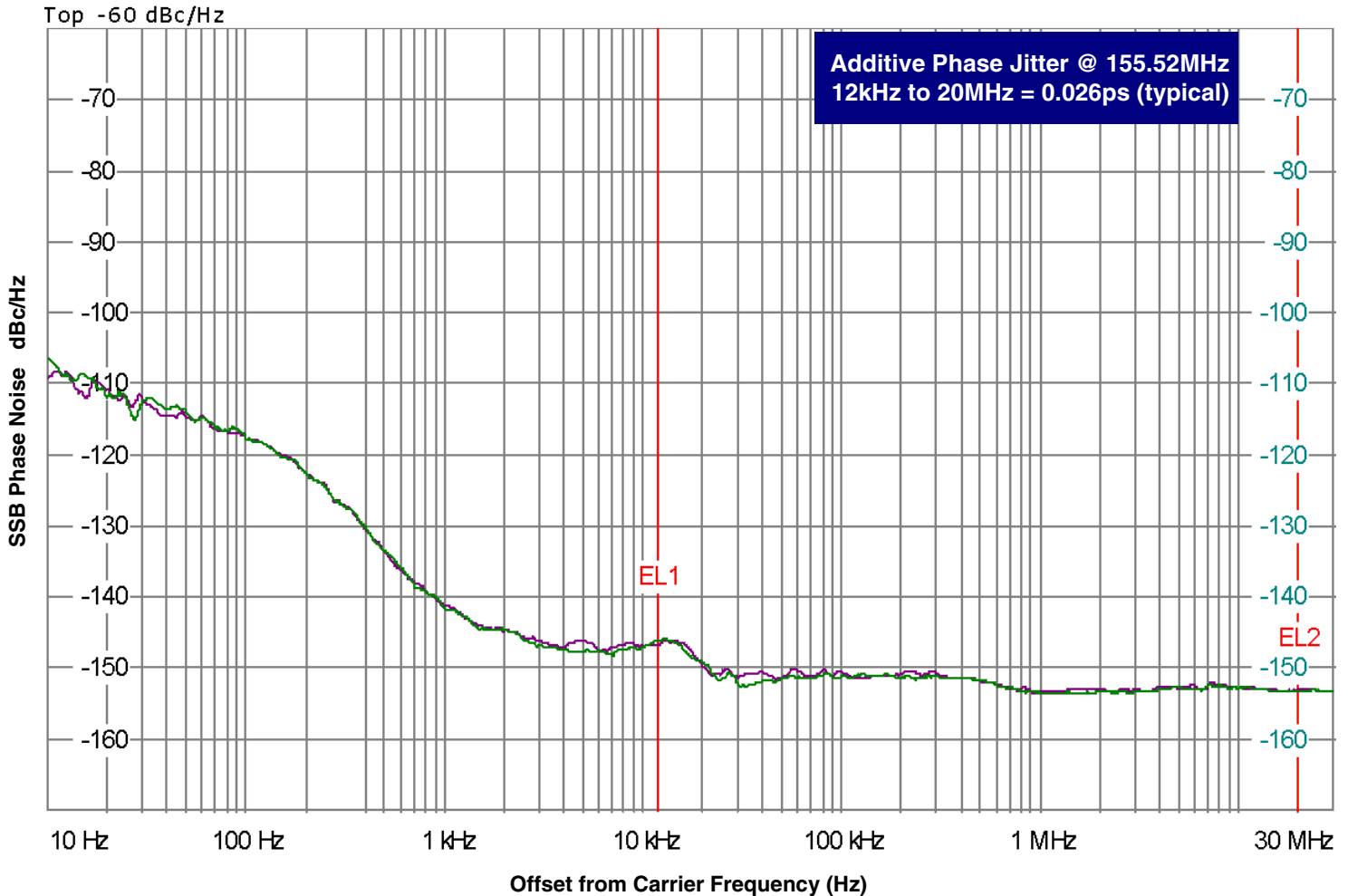

As with most timing specifications, phase noise measurements has issues relating to the limitations of the equipment. Often the noise floor of the equipment is higher than the noise floor of the device. This

is illustrated above. The device meets the noise floor of what is shown, but can actually be lower. The phase noise is dependent on the input source and measurement equipment.



## Parameter Measurement Information

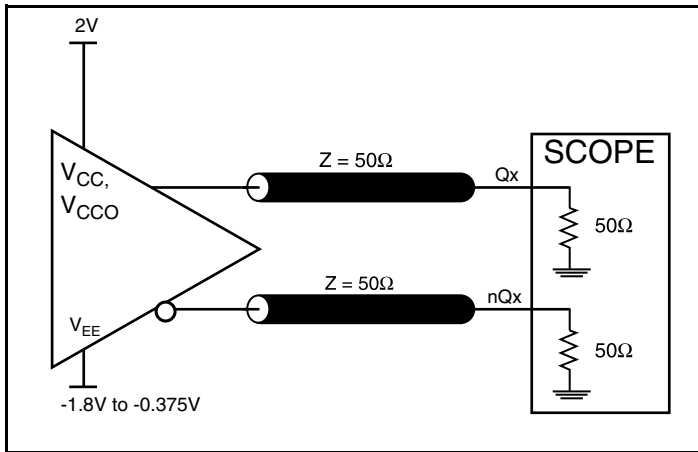

LVPECL Output Load AC Test Circuit

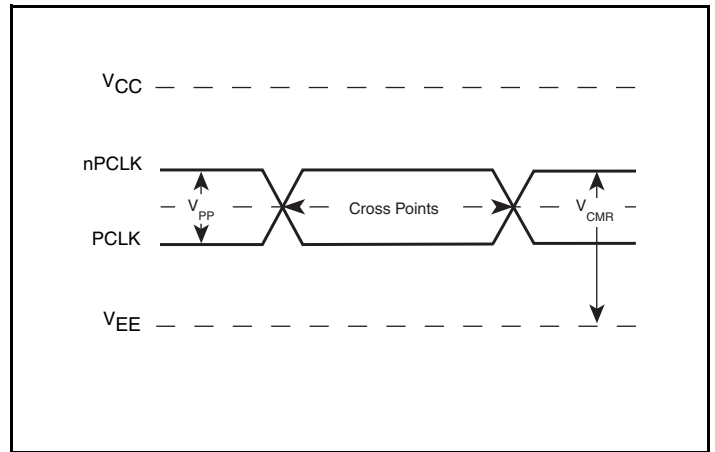

Differential Input Level

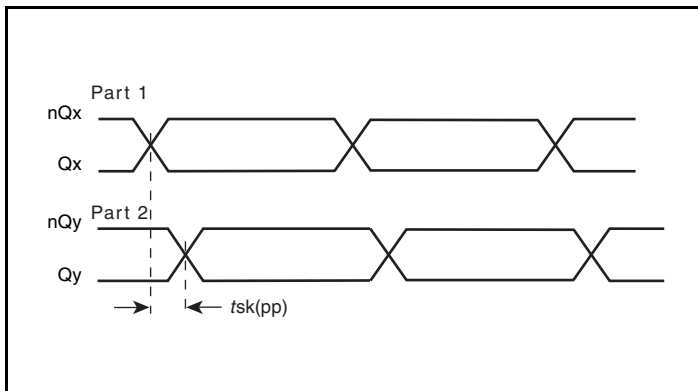

Part-to-Part Skew

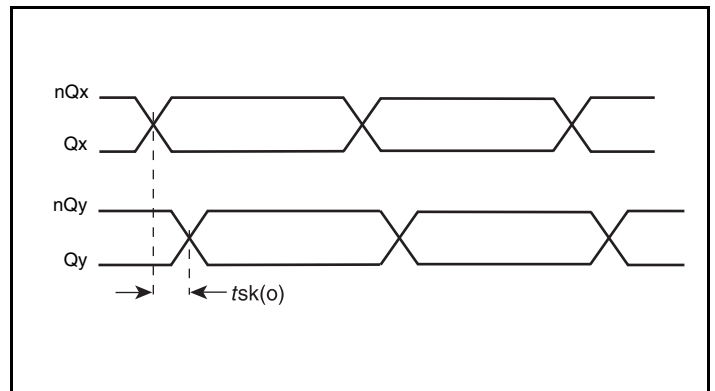

Output Skew

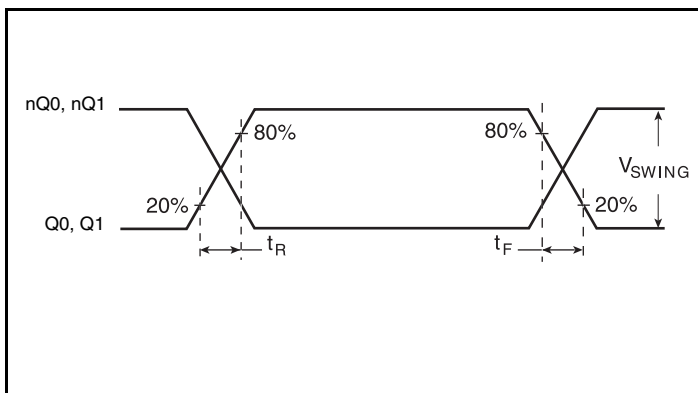

Output Rise/Fall Time

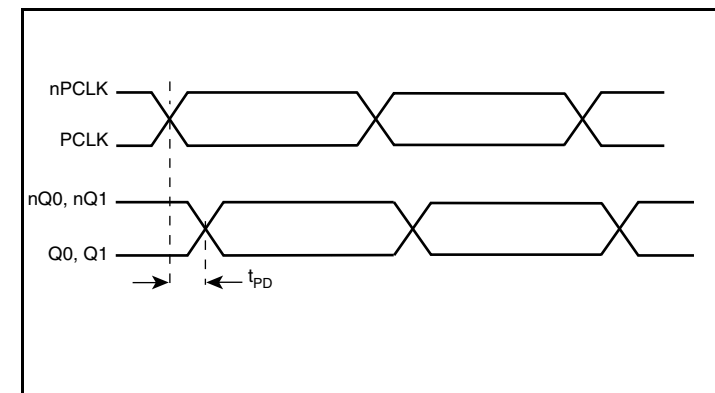

Propagation Delay

## Parameter Measurement Information, continued

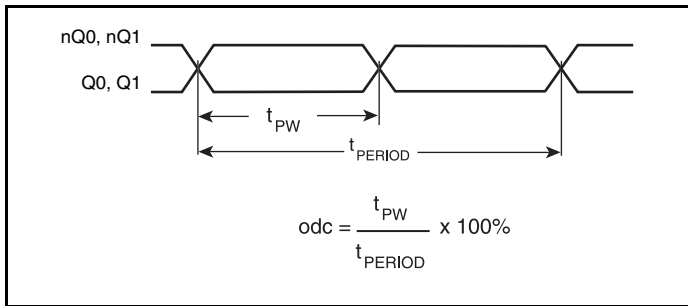

**Output Duty Cycle/Pulse Width/Period**

## Application Information

### Recommendations for Unused Output Pins

#### Outputs:

##### LVPECL Outputs

All unused LVPECL outputs can be left floating. We recommend that there is no trace attached. Both sides of the differential output pair should either be left floating or terminated.

### Wiring the Differential Input to Accept Single-Ended Levels

Figure 1 shows how a differential input can be wired to accept single ended levels. The reference voltage  $V_{REF} = V_{CC}/2$  is generated by the bias resistors R1 and R2. The bypass capacitor (C1) is used to help filter noise on the DC bias. This bias circuit should be located as close to the input pin as possible. The ratio of R1 and R2 might need to be adjusted to position the  $V_{REF}$  in the center of the input voltage swing. For example, if the input clock swing is 2.5V and  $V_{CC} = 3.3V$ , R1 and R2 value should be adjusted to set  $V_{REF}$  at 1.25V. The values below are for when both the single ended swing and  $V_{CC}$  are at the same voltage. This configuration requires that the sum of the output impedance of the driver ( $R_o$ ) and the series resistance ( $R_s$ ) equals the transmission line impedance. In addition, matched termination at the input will attenuate the signal in half. This can be done in one of two ways. First, R3 and R4 in parallel should equal the transmission

line impedance. For most 50Ω applications, R3 and R4 can be 100Ω. The values of the resistors can be increased to reduce the loading for slower and weaker LVCMOS driver. When using single-ended signaling, the noise rejection benefits of differential signaling are reduced. Even though the differential input can handle full rail LVCMOS signaling, it is recommended that the amplitude be reduced. The datasheet specifies a lower differential amplitude, however this only applies to differential signals. For single-ended applications, the swing can be larger, however  $V_{IL}$  cannot be less than -0.3V and  $V_{IH}$  cannot be more than  $V_{CC} + 0.3V$ . Though some of the recommended components might not be used, the pads should be placed in the layout. They can be utilized for debugging purposes. The datasheet specifications are characterized and guaranteed by using a differential signal.

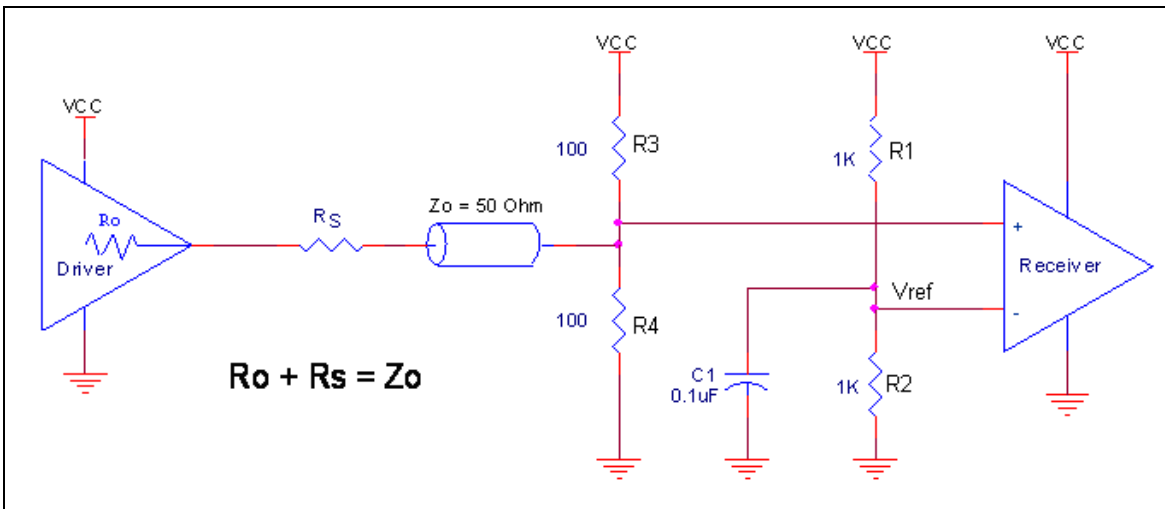
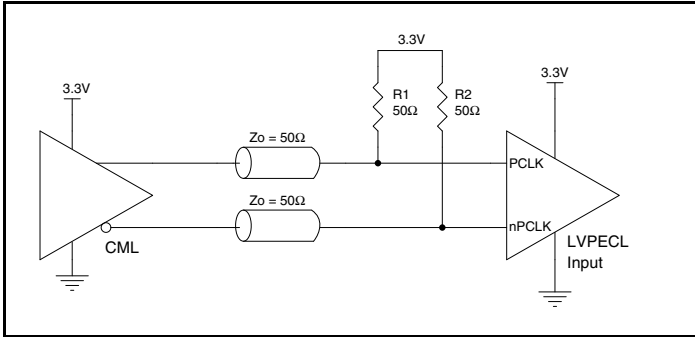

Figure 1. Recommended Schematic for Wiring a Differential Input to Accept Single-ended Levels

## LVPECL Clock Input Interface

The PCLK /nPCLK accepts LVPECL, LVDS, CML, SSTL and other differential signals. Both  $V_{SWING}$  and  $V_{OH}$  must meet the  $V_{PP}$  and  $V_{CMR}$  input requirements. *Figures 2A to 2F* show interface examples for the PCLK/nPCLK input driven by the most common driver types.

The input interfaces suggested here are examples only. If the driver is from another vendor, use their termination recommendation. Please consult with the vendor of the driver component to confirm the driver termination requirements.



**Figure 2A. PCLK/nPCLK Input Driven by a CML Driver**

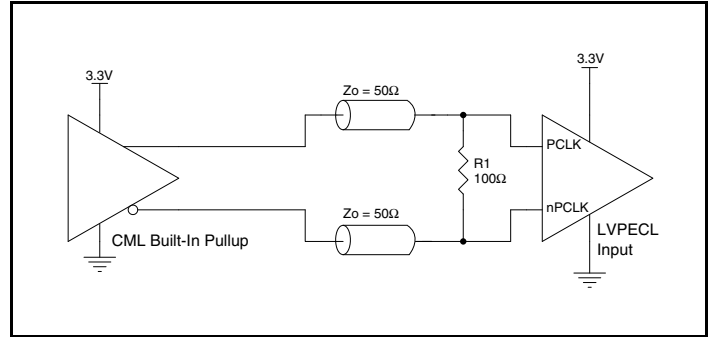

**Figure 2B. PCLK/nPCLK Input Driven by a Built-In Pullup CML Driver**

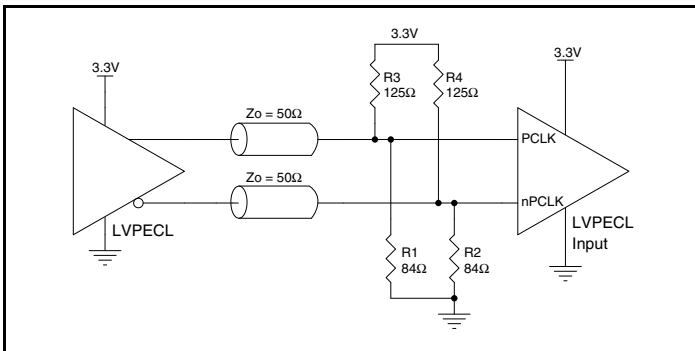

**Figure 2C. PCLK/nPCLK Input Driven by a 3.3V LVPECL Driver**

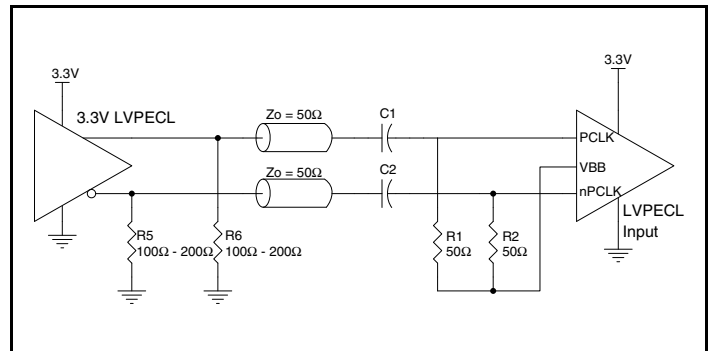

**Figure 2D. PCLK/nPCLK Input Driven by a 3.3V LVPECL Driver with AC Couple**

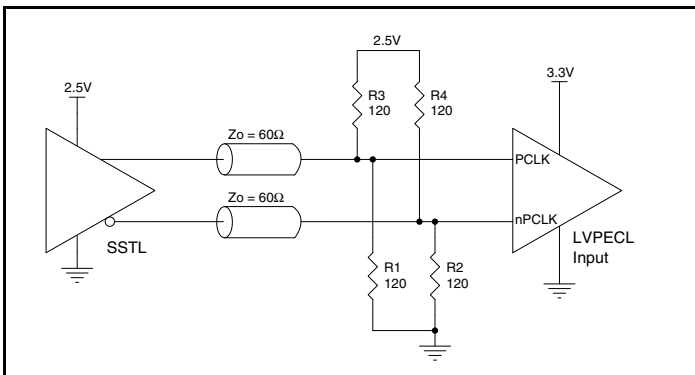

**Figure 2E. PCLK/nPCLK Input Driven by an SSTL Driver**

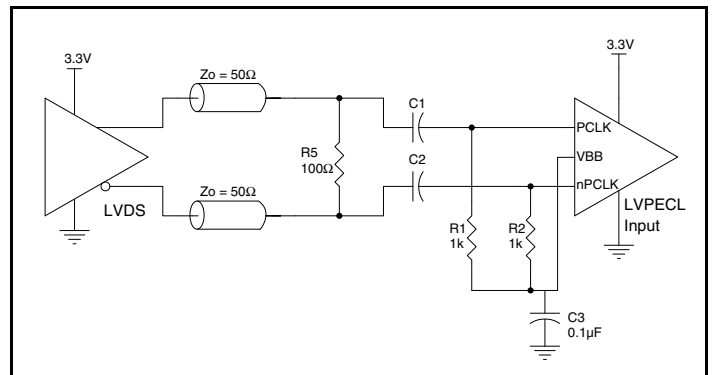

**Figure 2F. PCLK/nPCLK Input Driven by a 3.3V LVDS Driver**

### Termination for 3.3V LVPECL Outputs

The clock layout topology shown below is a typical termination for LVPECL outputs. The two different layouts mentioned are recommended only as guidelines.

The differential outputs are low impedance follower outputs that generate ECL/LVPECL compatible outputs. Therefore, terminating resistors (DC current path to ground) or current sources must be used for functionality. These outputs are designed to drive 50Ω

transmission lines. Matched impedance techniques should be used to maximize operating frequency and minimize signal distortion.

Figures 3A and 3B show two different layouts which are recommended only as guidelines. Other suitable clock layouts may exist and it would be recommended that the board designers simulate to guarantee compatibility across all printed circuit and clock component process variations.

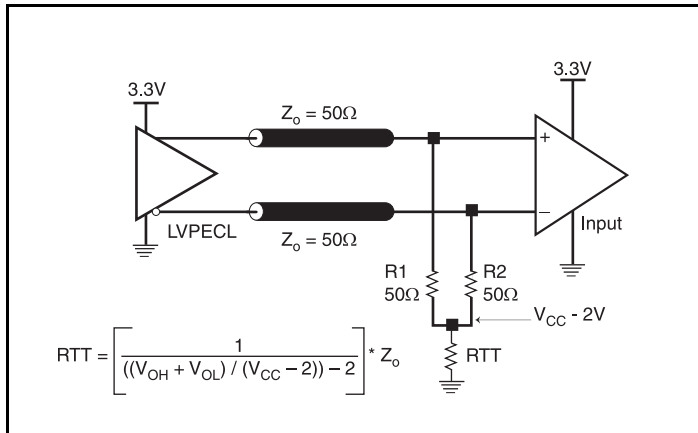

Figure 3A. 3.3V LVPECL Output Termination

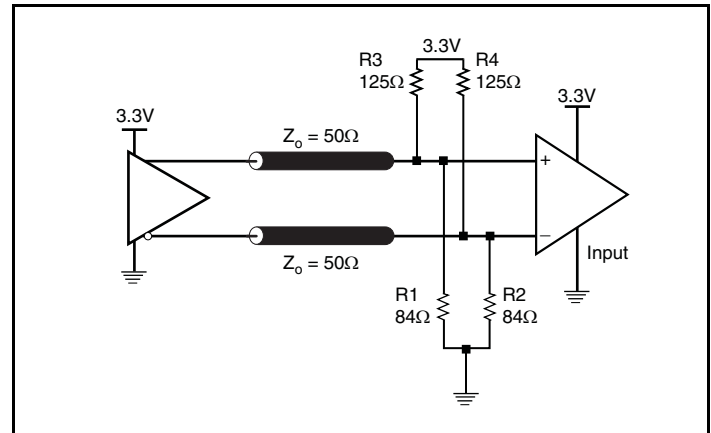

Figure 3B. 3.3V LVPECL Output Termination

### Termination for 2.5V LVPECL Outputs

Figure 4A and Figure 4B show examples of termination for 2.5V LVPECL driver. These terminations are equivalent to terminating  $50\Omega$  to  $V_{CC} - 2V$ . For  $V_{CC} = 2.5V$ , the  $V_{CC} - 2V$  is very close to ground

level. The R3 in Figure 4B can be eliminated and the termination is shown in Figure 4C.

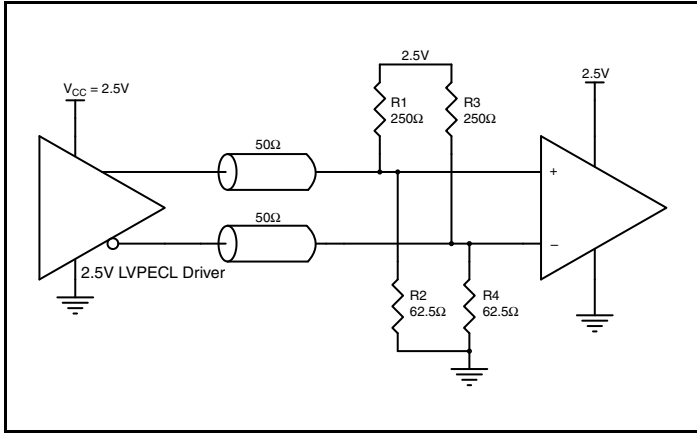

Figure 4A. 2.5V LVPECL Driver Termination Example

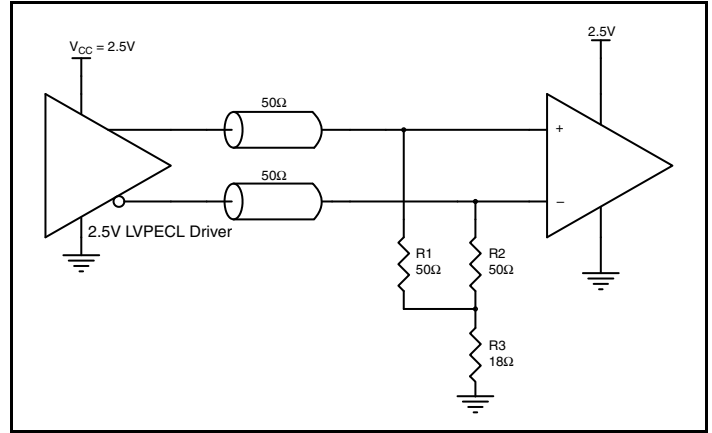

Figure 4B. 2.5V LVPECL Driver Termination Example

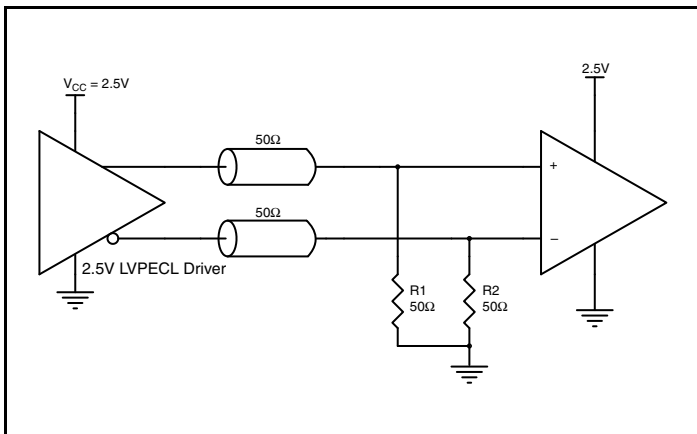

Figure 4C. 2.5V LVPECL Driver Termination Example

## Power Considerations

This section provides information on power dissipation and junction temperature for the 853S011B. Equations and example calculations are also provided.

### 1. Power Dissipation.

The total power dissipation for the 853S011B is the sum of the core power plus the power dissipated in the load(s). The following is the power dissipation for  $V_{CC} = 3.8V$ , which gives worst case results.

NOTE: Please refer to Section 3 for details on calculating power dissipated in the load.

- Power (core)<sub>MAX</sub> =  $V_{CC\_MAX} * I_{EE\_MAX} = 3.8V * 25mA = 95mW$
- Power (outputs)<sub>MAX</sub> = **29.86mW/Loaded Output pair**  
If all outputs are loaded, the total power is  $2 * 29.86mW = 59.72mW$

**Total Power<sub>MAX</sub>** (3.3V, with all outputs switching) =  $95mW + 59.72mW = 154.72mW$

### 2. Junction Temperature.

Junction temperature,  $T_j$ , is the temperature at the junction of the bond wire and bond pad directly affects the reliability of the device. The maximum recommended junction temperature is 125°C. Limiting the internal transistor junction temperature,  $T_j$ , to 125°C ensures that the bond wire and bond pad temperature remains below 125°C.

The equation for  $T_j$  is as follows:  $T_j = \theta_{JA} * Pd_{total} + T_a$

$T_j$  = Junction Temperature

$\theta_{JA}$  = Junction-to-Ambient Thermal Resistance

$Pd_{total}$  = Total Device Power Dissipation (example calculation is in section 1 above)

$T_a$  = Ambient Temperature

In order to calculate junction temperature, the appropriate junction-to-ambient thermal resistance  $\theta_{JA}$  must be used. Assuming no air flow and a multi-layer board, the appropriate value is 145.4°C/W per Table 5A below.

Therefore,  $T_j$  for an ambient temperature of 85°C with all outputs switching is:

$$85^\circ C + 0.155W * 145.4^\circ C/W = 107.5^\circ C. \text{ This is below the limit of } 125^\circ C.$$

This calculation is only an example.  $T_j$  will obviously vary depending on the number of loaded outputs, supply voltage, air flow and the type of board (multi-layer).

**Table 5A. Thermal Resistance  $\theta_{JA}$  for 8 Lead TSSOP, Forced Convection**

$\theta_{JA}$ vs. Air Flow			
Meters per Second	0	1	2.5
Multi-Layer PCB, JEDEC Standard Test Boards	145.4°C/W	141.3°C/W	139.3°C/W

**Table 5A. Thermal Resistance  $\theta_{JA}$  for 8 Lead SOIC, Forced Convection**

$\theta_{JA}$ vs. Air Flow			
Meters per Second	0	1	2.5
Multi-Layer PCB, JEDEC Standard Test Boards	102.0°C/W	95.0°C/W	90.6°C/W

### 3. Calculations and Equations.

The purpose of this section is to derive the power dissipation for the LVPECL output pairs.

LVPECL output driver circuit and termination are shown in *Figure 5*.

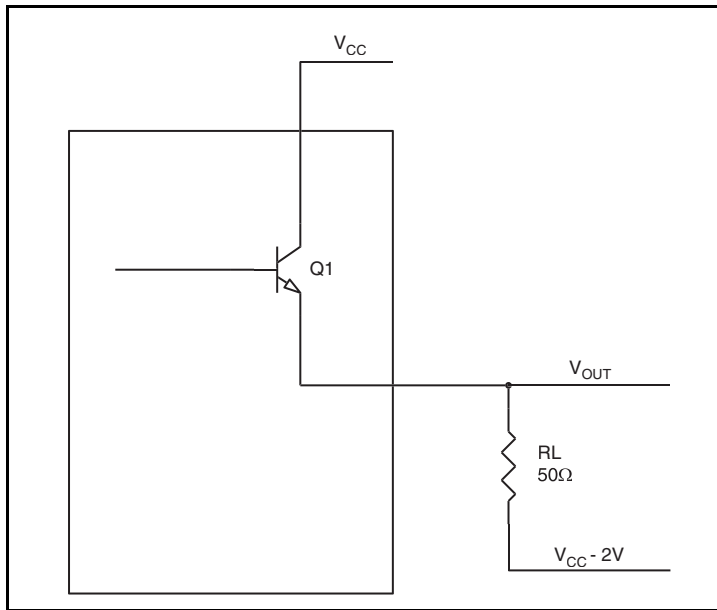

**Figure 5. LVPECL Driver Circuit and Termination**

To calculate worst case power dissipation into the load, use the following equations which assume a 50Ω load, and a termination voltage of  $V_{CC} - 2V$ .

- For logic high,  $V_{OUT} = V_{OH\_MAX} = V_{CC\_MAX} - 0.905V$   
 $(V_{CC\_MAX} - V_{OH\_MAX}) = 0.905V$
- For logic low,  $V_{OUT} = V_{OL\_MAX} = V_{CC\_MAX} - 1.705V$   
 $(V_{CC\_MAX} - V_{OL\_MAX}) = 1.705V$

$Pd\_H$  is power dissipation when the output drives high.

$Pd\_L$  is the power dissipation when the output drives low.

$$Pd\_H = [(V_{OH\_MAX} - (V_{CC\_MAX} - 2V))/R_L] * (V_{CC\_MAX} - V_{OH\_MAX}) = [(2V - (V_{CC\_MAX} - V_{OH\_MAX}))/R_L] * (V_{CC\_MAX} - V_{OH\_MAX}) = [(2V - 0.905V)/50\Omega] * 0.905V = 19.8mW$$

$$Pd\_L = [(V_{OL\_MAX} - (V_{CC\_MAX} - 2V))/R_L] * (V_{CC\_MAX} - V_{OL\_MAX}) = [(2V - (V_{CC\_MAX} - V_{OL\_MAX}))/R_L] * (V_{CC\_MAX} - V_{OL\_MAX}) = [(2V - 1.705V)/50\Omega] * 1.705V = 10.06mW$$

$$\text{Total Power Dissipation per output pair} = Pd\_H + Pd\_L = 29.86mW$$



## Reliability Information

**Table 6A.  $\theta_{JA}$  vs. Air Flow Table for a 8 Lead TSSOP**

$\theta_{JA}$ vs. Air Flow			
Meters per Second	0	1	2.5
Multi-Layer PCB, JEDEC Standard Test Boards	145.4°C/W	141.3°C/W	139.3°C/W

**Table 6B.  $\theta_{JA}$  vs. Air Flow Table for a 8 Lead SOIC**

$\theta_{JA}$ vs. Air Flow			
Meters per Second	0	1	2.5
Multi-Layer PCB, JEDEC Standard Test Boards	102.0°C/W	95.0°C/W	90.6°C/W

## Transistor Count

The transistor count for 853S011B is: 208

This device is pin compatible with and is the suggested replacement for the 853011B and 853011C.

# Package Outlines and Package Dimensions

Package Outline - G Suffix for 8 Lead TSSOP

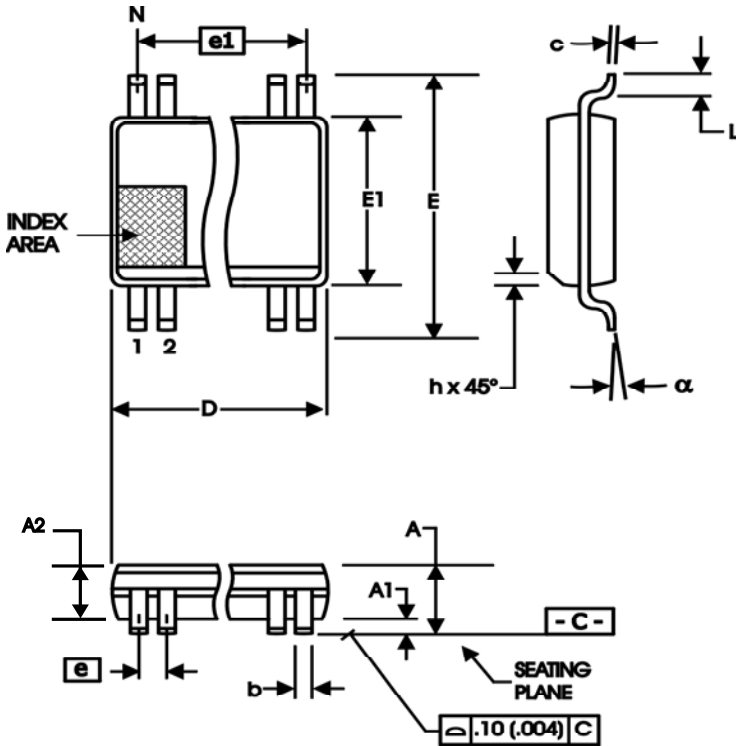

Package Outline - M Suffix for 8 Lead SOIC

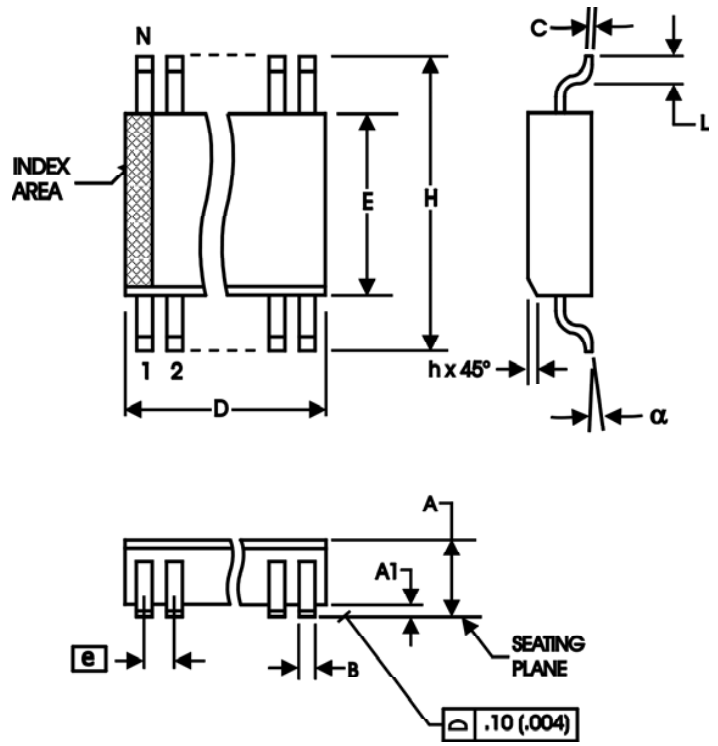

Table 7A. Package Dimensions

All Dimensions in Millimeters		
Symbol	Minimum	Maximum
N	8	
A		1.10
A1	0	0.15
A2	0.79	0.97
b	0.22	0.38
c	0.08	0.23
D	3.00 Basic	
E	4.90 Basic	
E1	3.00 Basic	
e	0.65 Basic	
e1	1.95 Basic	
L	0.40	0.80
α	0°	8°
aaa		0.10

Reference Document: JEDEC Publication 95, MO-187

Table 7B. Package Dimensions

All Dimensions in Millimeters		
Symbol	Minimum	Maximum
N	8	
A	1.35	1.75
A1	0.10	0.25
B	0.33	0.51
C	0.19	0.25
D	4.80	5.00
E	3.80	4.00
e	1.27 Basic	
H	5.80	6.20
h	0.25	0.50
L	0.40	1.27
α	0°	8°

Reference Document: JEDEC Publication 95, MS-012

## Ordering Information

**Table 8. Ordering Information**

<b>Part/Order Number</b>	<b>Marking</b>	<b>Package</b>	<b>Shipping Packaging</b>	<b>Temperature</b>
853S011BMILF	3S011BIL	"Lead Free" 8 Lead SOIC	Tube	-40°C to 85°C
853S011BMILFT	3S011BIL	"Lead Free" 8 Lead SOIC	Tape & Reel	-40°C to 85°C
853S011BGILF	1BIL	"Lead Free" 8 Lead TSSOP	Tube	-40°C to 85°C
853S011BGILFT	1BIL	"Lead Free" 8 Lead TSSOP	Tape & Reel	-40°C to 85°C

## Revision History Sheet

Rev	Table	Page	Description of Change	Date
A	T3B - T3D	4, 5	LVPECL/ECL DC Characteristics Tables - updated notes. Corrected $V_{PP}$ unit from V to mV.	5/12/10
		10	Updated "Wiring the Differential Input to Accept Single-ended Levels" section.	
	T8	18	Ordering Information Table - corrected TSSOP marking.	
B	T8	18	General Description - deleted HiperClocks logo. Ordering Information Table - deleted Tape & Reel count and note. Deleted "ICS" prefix and "I" suffix in the part number throughout the datasheet. Updated datasheet header/footer.	2/23/16



**Corporate Headquarters**  
6024 Silver Creek Valley Road  
San Jose, CA 95138 USA

**Sales**  
1-800-345-7015 or 408-284-8200  
Fax: 408-284-2775  
www.IDT.com

**Tech Support**  
email: [clocks@idt.com](mailto:clocks@idt.com)

DISCLAIMER Integrated Device Technology, Inc. (IDT) and its subsidiaries reserve the right to modify the products and/or specifications described herein at any time and at IDT's sole discretion. All information in this document, including descriptions of product features and performance, is subject to change without notice. Performance specifications and the operating parameters of the described products are determined in the independent state and are not guaranteed to perform the same way when installed in customer products. The information contained herein is provided without representation or warranty of any kind, whether express or implied, including, but not limited to, the suitability of IDT's products for any particular purpose, an implied warranty of merchantability, or non-infringement of the intellectual property rights of others. This document is presented only as a guide and does not convey any license under intellectual property rights of IDT or any third parties.

IDT's products are not intended for use in applications involving extreme environmental conditions or in life support systems or similar devices where the failure or malfunction of an IDT product can be reasonably expected to significantly affect the health or safety of users. Anyone using an IDT product in such a manner does so at their own risk, absent an express, written agreement by IDT.

While the information presented herein has been checked for both accuracy and reliability, Integrated Device Technology (IDT) assumes no responsibility for either its use or for the infringement of any patents or other rights of third parties, which would result from its use. No other circuits, patents, or licenses are implied. This product is intended for use in normal commercial applications. Any other applications, such as those requiring extended temperature ranges, high reliability or other extraordinary environmental requirements are not recommended without additional processing by IDT. IDT reserves the right to change any circuitry or specifications without notice. IDT does not authorize or warrant any IDT product for use in life support devices or critical medical instruments.

Integrated Device Technology, IDT and the IDT logo are registered trademarks of IDT. Product specification subject to change without notice. Other trademarks and service marks used herein, including protected names, logos and designs, are the property of IDT or their respective third party owners.

Copyright ©2016 Integrated Device Technology, Inc. All rights reserved.