



Chipsmall Limited consists of a professional team with an average of over 10 year of expertise in the distribution of electronic components. Based in Hongkong, we have already established firm and mutual-benefit business relationships with customers from,Europe,America and south Asia,supplying obsolete and hard-to-find components to meet their specific needs.

With the principle of “Quality Parts,Customers Priority,Honest Operation,and Considerate Service”,our business mainly focus on the distribution of electronic components. Line cards we deal with include Microchip,ALPS,ROHM,Xilinx,Pulse,ON,Everlight and Freescale. Main products comprise IC,Modules,Potentiometer,IC Socket,Relay,Connector.Our parts cover such applications as commercial,industrial, and automotives areas.

We are looking forward to setting up business relationship with you and hope to provide you with the best service and solution. Let us make a better world for our industry!



Contact us

Tel: +86-755-8981 8866 Fax: +86-755-8427 6832

Email & Skype: info@chipsmall.com Web: www.chipsmall.com

Address: A1208, Overseas Decoration Building, #122 Zhenhua RD., Futian, Shenzhen, China





LOW SKEW, 1-TO-12, DIFFERENTIAL-TO-3.3V, 2.5V LVPECL FANOUT BUFFER

ICS853S12I

GENERAL DESCRIPTION



The ICS853S12I is a low skew, 1-to-12 Differential-to-3.3V, 2.5V LVPECL Fanout Buffer and a member of the HiPerClockS™ family of High Performance Clock Solutions from IDT. The PCLK, nPCLK pair accepts LVPECL, CML, and SSTL differential input levels. The high gain differential amplifier accepts peak-to-peak input voltages as small as 150mV, as long as the common mode voltage is within the specified minimum and maximum range.

Guaranteed output and part-to-part skew characteristics make the ICS853S12I ideal for those clock distribution applications demanding well defined performance and repeatability.

FEATURES

- Twelve differential 3.3V, 2.5V LVPECL outputs
- PCLK, nPCLK input pair
- PCLK, nPCLK pair can accept the following differential input levels: LVPECL, CML, SSTL
- Maximum output frequency: 1.5GHz
- Translates any single-ended input signal to 2.5V or 3.3V LVPECL levels with a resistor bias on nPCLK input
- Additive phase jitter, RMS: 0.06ps (typical)
- Output skew: 50ps (maximum)
- Part-to-part skew: 250ps (maximum)
- Propagation delay: 680ps (maximum)
- Full 3.3V or 2.5V operating supply modes
- -40°C to 85°C ambient operating temperature
- Available in lead-free (RoHS 6) package

BLOCK DIAGRAM

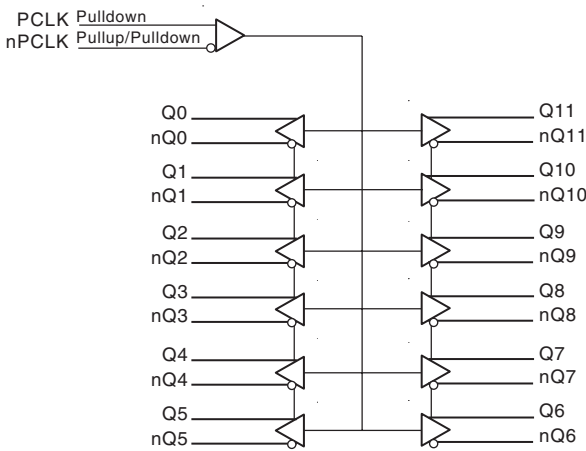

PIN ASSIGNMENT

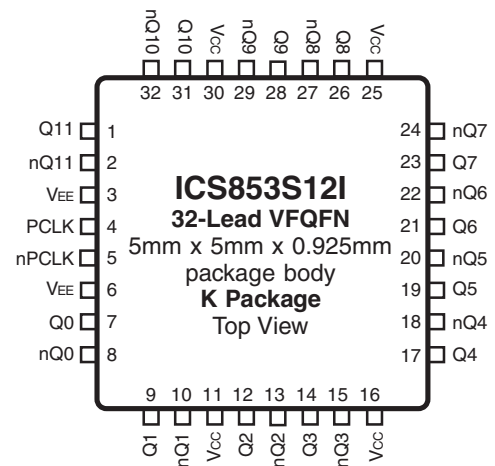

TABLE 1. PIN DESCRIPTIONS

Number	Name	Type		Description
1, 2	Q11, nQ11	Output		Differential output pair. LVPECL interface levels.
3, 6	V _{EE}	Power		Negative supply pins.
4	PCLK	Input	Pulldown	Non-inverting differential clock input.
5	nPCLK	Input	Pullup/ Pulldown	Inverting differential clock input.
7, 8	Q0, nQ0	Output		Differential output pair. LVPECL interface levels.
9, 10	Q1, nQ1	Output		Differential output pair. LVPECL interface levels.
11, 16, 25, 30	V _{CC}	Power		Positive supply pins.
12, 13	Q2, nQ2	Output		Differential output pair. LVPECL interface levels.
14, 15	Q3, nQ3	Output		Differential output pair. LVPECL interface levels.
17, 18	Q4, nQ4	Output		Differential output pair. LVPECL interface levels.
19, 20	Q5, nQ5	Output		Differential output pair. LVPECL interface levels..
21, 22	Q6, nQ6	Output		Differential output pair. LVPECL interface levels.
23, 24	Q7, nQ7	Output		Differential output pair. LVPECL interface levels.
28, 29	Q9, nQ9	Output		Differential output pair. LVPECL interface levels.
26, 27	Q8, nQ8	Output		Differential output pair. LVPECL interface levels.
31, 32	Q10, nQ10	Output		Differential output pair. LVPECL interface levels.

NOTE: *Pullup* and *Pulldown* refer to internal input resistors. See Table 2, Pin Characteristics, for typical values.

TABLE 2. PIN CHARACTERISTICS

Symbol	Parameter	Test Conditions	Minimum	Typical	Maximum	Units
C _{IN}	Input Capacitance			2		pF
R _{PULLUP}	Input Pullup Resistor			50		kΩ
R _{PULLDOWN}	Input Pulldown Resistor			50		kΩ

TABLE 3. CLOCK INPUT FUNCTION TABLE

Inputs		Outputs		Input to Output Mode	Polarity
PCLK	nPCLK	Q0:Q11	nQ0:nQ11		
0	1	LOW	HIGH	Differential to Differential	Non Inverting
1	0	HIGH	LOW	Differential to Differential	Non Inverting
0	Biased; NOTE 1	LOW	HIGH	Single Ended to Differential	Non Inverting
1	Biased; NOTE 1	HIGH	LOW	Single Ended to Differential	Non Inverting
Biased; NOTE 1	0	HIGH	LOW	Single Ended to Differential	Inverting
Biased; NOTE 1	1	LOW	HIGH	Single Ended to Differential	Inverting

NOTE 1: Please refer to the Application Information "Wiring the Differential Input to Accept Single Ended Levels".

ABSOLUTE MAXIMUM RATINGS

Supply Voltage, V_{CC}	4.6V
Inputs, V_I	-0.5V to $V_{CC} + 0.5V$
Outputs, I_O	
Continuous Current	50mA
Surge Current	100mA
Package Thermal Impedance, θ_{JA} For 32 Lead VFQFN	42.7°C/W (0 mps)
Storage Temperature, T_{STG}	-65°C to 150°C

NOTE: Stresses beyond those listed under Absolute Maximum Ratings may cause permanent damage to the device. These ratings are stress specifications only. Functional operation of product at these conditions or any conditions beyond those listed in the *DC Characteristics* or *AC Characteristics* is not implied. Exposure to absolute maximum rating conditions for extended periods may affect product reliability.

TABLE 4A. POWER SUPPLY DC CHARACTERISTICS, $V_{CC} = 3.3V \pm 5\%$, $V_{EE} = 0V$, $T_A = -40^\circ C$ TO $85^\circ C$

Symbol	Parameter	Test Conditions	Minimum	Typical	Maximum	Units
V_{CC}	Positive Supply Voltage		3.135	3.3	3.465	V
I_{EE}	Power Supply Current				137	mA

TABLE 4B. POWER SUPPLY DC CHARACTERISTICS, $V_{CC} = 2.5V \pm 5\%$, $V_{EE} = 0V$, $T_A = -40^\circ C$ TO $85^\circ C$

Symbol	Parameter	Test Conditions	Minimum	Typical	Maximum	Units
V_{CC}	Positive Supply Voltage		2.375	2.5	2.625	V
I_{EE}	Power Supply Current				130	mA

TABLE 4C. LVPECL DC CHARACTERISTICS, $V_{CC} = 3.3V \pm 5\%$ OR $2.5V \pm 5\%$, $V_{EE} = 0V$, $T_A = -40^\circ C$ TO $85^\circ C$

Symbol	Parameter	Test Conditions	Minimum	Typical	Maximum	Units
I_{IH}	Input High Current	PCLK	$V_{CC} = V_{IN} = 3.465V$ or $2.625V$		150	μA
		nPCLK	$V_{CC} = V_{IN} = 3.465V$ or $2.625V$		10	μA
I_{IL}	Input Low Current	PCLK	$V_{CC} = 3.465V$ or $2.625V$, $V_{IN} = 0V$	-10		μA
		nPCLK	$V_{CC} = 3.465V$ or $2.625V$, $V_{IN} = 0V$	-150		μA
V_{PP}	Peak-to-Peak Input Voltage		0.3		1.0	V
V_{CMR}	Common Mode Input Voltage; NOTE 1, 2		$V_{EE} + 1.5$		V_{CC}	V
V_{OH}	Output High Voltage; NOTE 3		$V_{CC} - 1.3$		$V_{CC} - 0.8$	V
V_{OL}	Output Low Voltage; NOTE 3		$V_{CC} - 2.0$		$V_{CC} - 1.6$	V
V_{SWING}	Peak-to-Peak Output Voltage Swing		0.6		1.0	V

NOTE 1: For single ended applications, the maximum input voltage for PCLK, nPCLK is $V_{CC} + 0.3V$.

NOTE 2: Common mode voltage is defined as V_{IH} .

NOTE 3: Outputs terminated with 50Ω to $V_{CC} - 2V$.

TABLE 5. AC CHARACTERISTICS, $V_{CC} = 3.3V \pm 5\%$ OR , $V_{CC} = 2.5V \pm 5\%$, $V_{EE} = 0V$, $T_A = -40^\circ C$ TO $85^\circ C$

Symbol	Parameter	Test Conditions	Minimum	Typical	Maximum	Units
f_{MAX}	Output Frequency				1.5	GHz
t_{PD}	Propagation Delay; NOTE 1		300		680	ps
f_{jit}	Buffer Additive Phase Jitter, RMS; refer to Additive Phase Jitter Section	622MHz, Integration Range: 12kHz – 20MHz		0.06		ps
$t_{sk(o)}$	Output Skew; NOTE 2, 4				50	ps
$t_{sk(pp)}$	Part-to-Part Skew; NOTE 3, 4				250	ps
t_R / t_F	Output Rise/Fall Time	20% to 80%	80		300	ps
odc	Output Duty Cycle		47		53	%

NOTE 1: Measured from the differential input crossing point to the differential output crossing point.

NOTE 2: Defined as skew between outputs at the same supply voltage and with equal load conditions.

Measured at the output differential cross points.

NOTE 3: Defined as skew between outputs on different devices operating at the same supply voltages and with equal load conditions. Using the same type of inputs on each device, the outputs are measured at the differential cross points.

NOTE 4: This parameter is defined in accordance with JEDEC Standard 65.

ADDITIVE PHASE JITTER

The spectral purity in a band at a specific offset from the fundamental compared to the power of the fundamental is called the ***dBc Phase Noise***. This value is normally expressed using a Phase noise plot and is most often the specified plot in many applications. Phase noise is defined as the ratio of the noise power present in a 1Hz band at a specified offset from the fundamental frequency to the power value of the fundamental. This ratio is expressed in decibels (dBm) or a ratio of the power in the 1Hz

band to the power in the fundamental. When the required offset is specified, the phase noise is called a ***dBc*** value, which simply means dBm at a specified offset from the fundamental. By investigating jitter in the frequency domain, we get a better understanding of its effects on the desired application over the entire time record of the signal. It is mathematically possible to calculate an expected bit error rate given a phase noise plot.

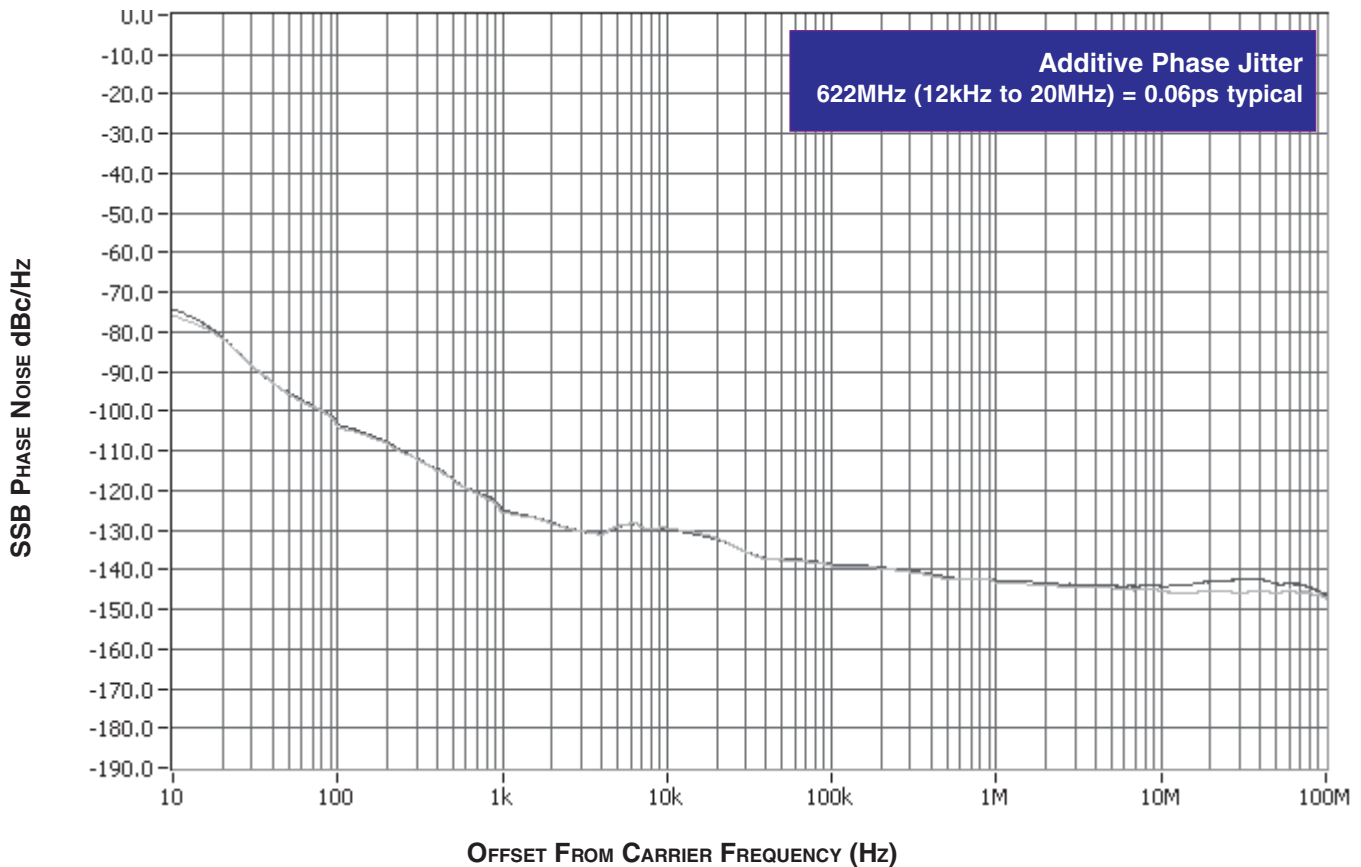

As with most timing specifications, phase noise measurements has issues relating to the limitations of the equipment. Often the noise floor of the equipment is higher than the noise floor of the

device. This is illustrated above. The device meets the noise floor of what is shown, but can actually be lower. The phase noise is dependent on the input source and measurement equipment.

PARAMETER MEASUREMENT INFORMATION

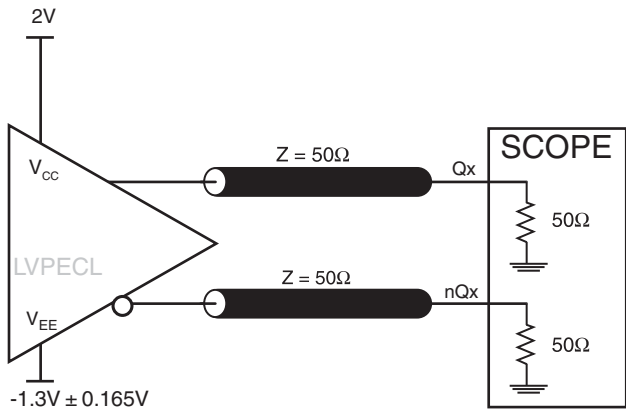

OUTPUT LOAD 3.3V AC TEST CIRCUIT

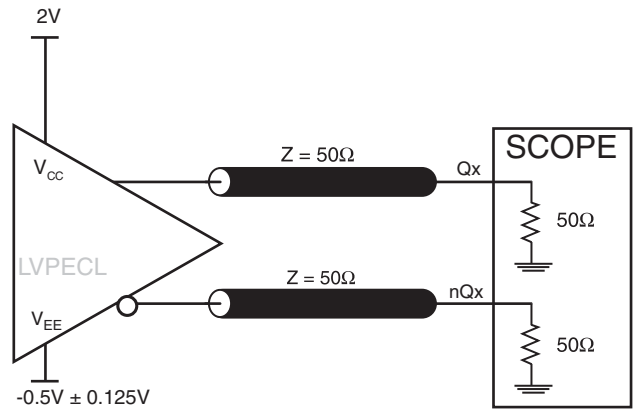

OUTPUT LOAD 2.5V AC TEST CIRCUIT

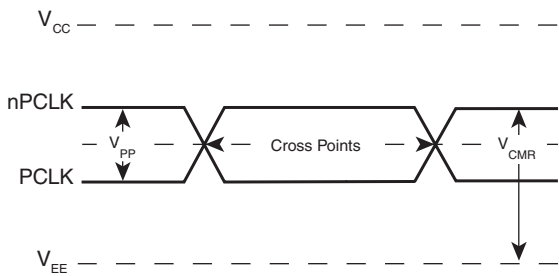

DIFFERENTIAL INPUT LEVEL

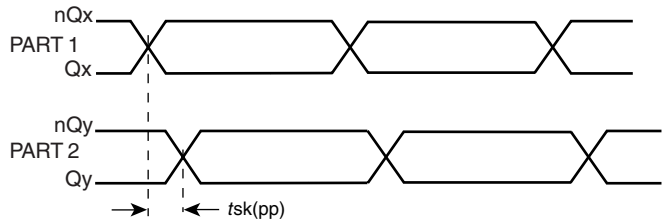

PART-TO-PART SKEW

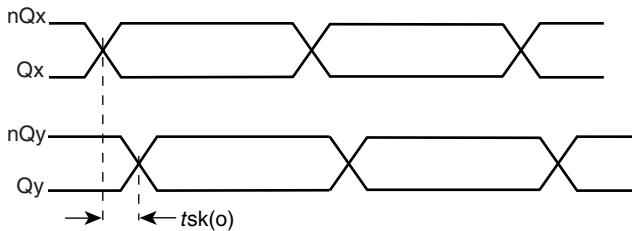

OUTPUT SKEW

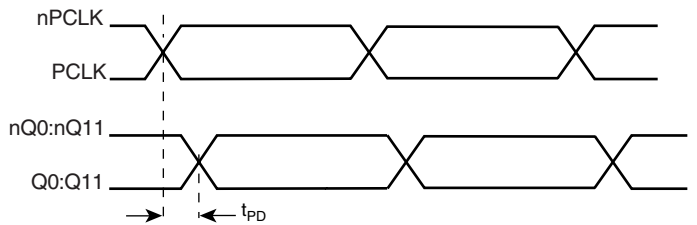

PROPAGATION DELAY

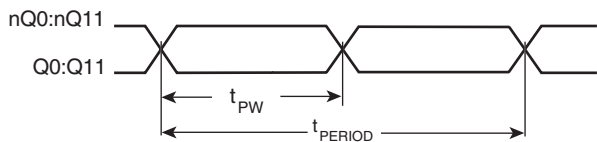

$$\text{odc} = \frac{t_{PW}}{t_{PERIOD}} \times 100\%$$

OUTPUT DUTY CYCLE/PULSE WIDTH/PERIOD

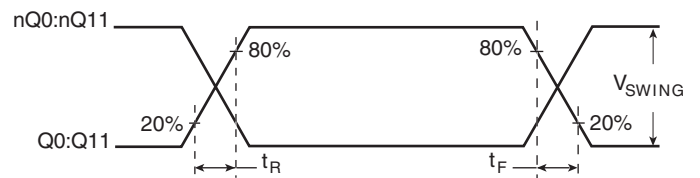

OUTPUT RISE/FALL TIME

APPLICATION INFORMATION

WIRING THE DIFFERENTIAL INPUT TO ACCEPT SINGLE ENDED LEVELS

Figure 1 shows how the differential input can be wired to accept single ended levels. The reference voltage $V_{REF} = V_{CC}/2$ is generated by the bias resistors R1, R2 and C1. This bias circuit should be located as close as possible to the input pin. The ratio

of R1 and R2 might need to be adjusted to position the V_{REF} in the center of the input voltage swing. For example, if the input clock swing is only 2.5V and $V_{CC} = 3.3V$, V_{REF} should be 1.25V and $R2/R1 = 0.609$.

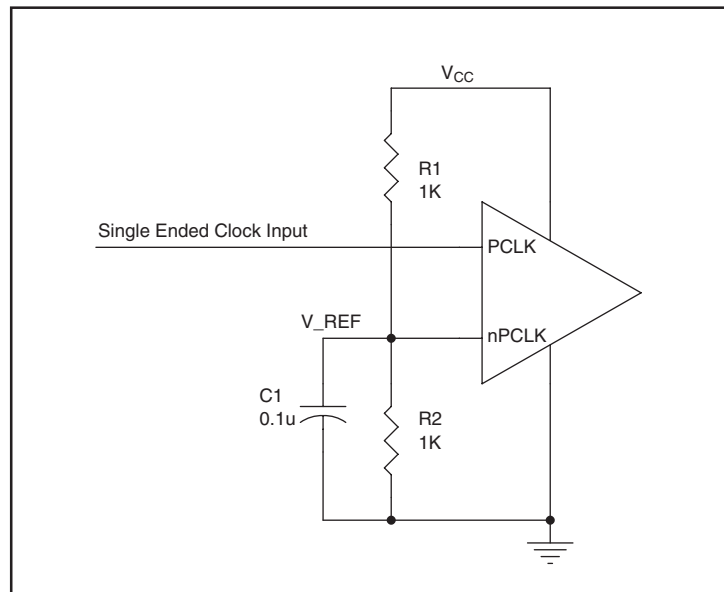

FIGURE 1. SINGLE ENDED SIGNAL DRIVING DIFFERENTIAL INPUT

RECOMMENDATIONS FOR UNUSED OUTPUT PINS

OUTPUTS:

LVPECL OUTPUTS:

All unused LVPECL outputs can be left floating. We recommend that there is no trace attached. Both sides of the differential output pair should either be left floating or terminated.

LVPECL CLOCK INPUT INTERFACE

The PCLK /nPCLK accepts LVPECL, CML, SSTL and other differential signals. Both V_{SWING} and V_{OH} must meet the V_{PP} and V_{CMR} input requirements. Figures 2A to 2E show interface examples for the HiPerClockS PCLK/nPCLK input driven by the most common driver types. The input interfaces suggest-

ed here are examples only. If the driver is from another vendor, use their termination recommendation. Please consult with the vendor of the driver component to confirm the driver termination requirements.

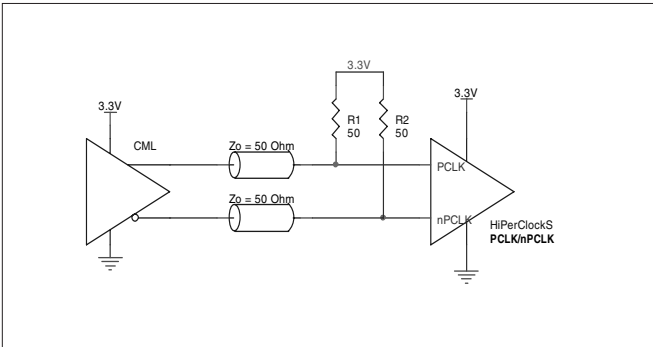

FIGURE 2A. HiPerClockS PCLK/nPCLK INPUT DRIVEN BY A CML DRIVER

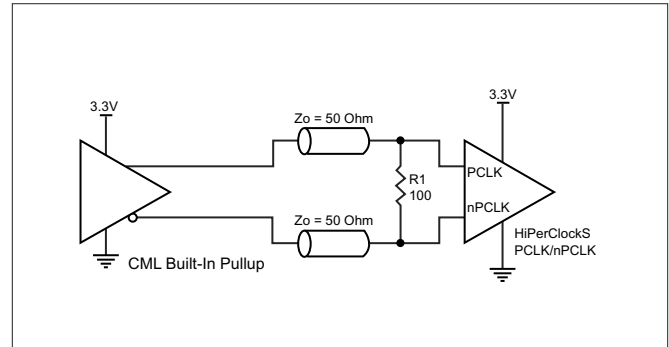

FIGURE 2B. HiPerClockS PCLK/nPCLK INPUT DRIVEN BY A BUILT-IN PULLUP CML DRIVER

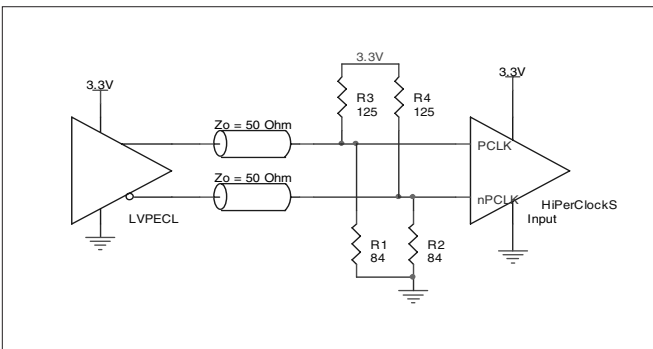

FIGURE 2C. HiPerClockS PCLK/nPCLK INPUT DRIVEN BY A 3.3V LVPECL DRIVER

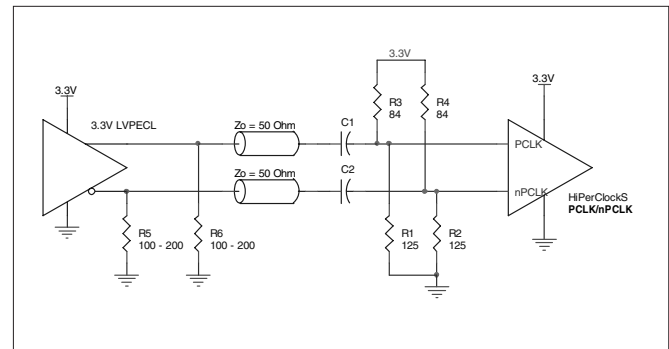

FIGURE 2D. HiPerClockS PCLK/nPCLK INPUT DRIVEN BY A 3.3V LVPECL DRIVER WITH AC COUPLE

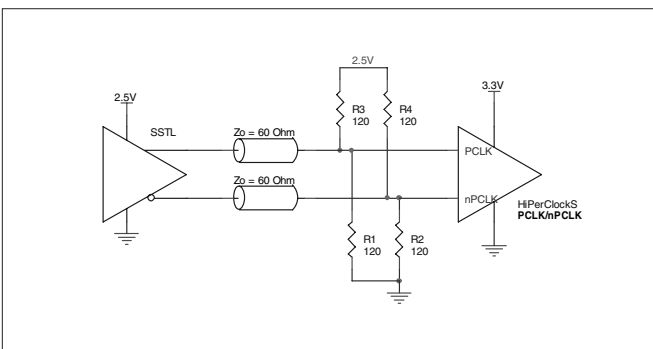

FIGURE 2E. HiPerClockS PCLK/nPCLK INPUT DRIVEN BY AN SSTL DRIVER

VFQFN EPAD THERMAL RELEASE PATH

In order to maximize both the removal of heat from the package and the electrical performance, a land pattern must be incorporated on the Printed Circuit Board (PCB) within the footprint of the package corresponding to the exposed metal pad or exposed heat slug on the package, as shown in *Figure 3*. The solderable area on the PCB, as defined by the solder mask, should be at least the same size/shape as the exposed pad/slug area on the package to maximize the thermal/electrical performance. Sufficient clearance should be designed on the PCB between the outer edges of the land pattern and the inner edges of pad pattern for the leads to avoid any shorts.

While the land pattern on the PCB provides a means of heat transfer and electrical grounding from the package to the board through a solder joint, thermal vias are necessary to effectively conduct from the surface of the PCB to the ground plane(s). The land pattern must be connected to ground through these vias. The vias act as “heat pipes”. The number of vias (i.e. “heat pipes”)

are application specific and dependent upon the package power dissipation as well as electrical conductivity requirements. Thus, thermal and electrical analysis and/or testing are recommended to determine the minimum number needed. Maximum thermal and electrical performance is achieved when an array of vias is incorporated in the land pattern. It is recommended to use as many vias connected to ground as possible. It is also recommended that the via diameter should be 12 to 13mils (0.30 to 0.33mm) with 1oz copper via barrel plating. This is desirable to avoid any solder wicking inside the via during the soldering process which may result in voids in solder between the exposed pad/slug and the thermal land. Precautions should be taken to eliminate any solder voids between the exposed heat slug and the land pattern. Note: These recommendations are to be used as a guideline only. For further information, refer to the Application Note on the *Surface Mount Assembly* of Amkor’s Thermally/Electrically Enhance Leadframe Base Package, Amkor Technology.

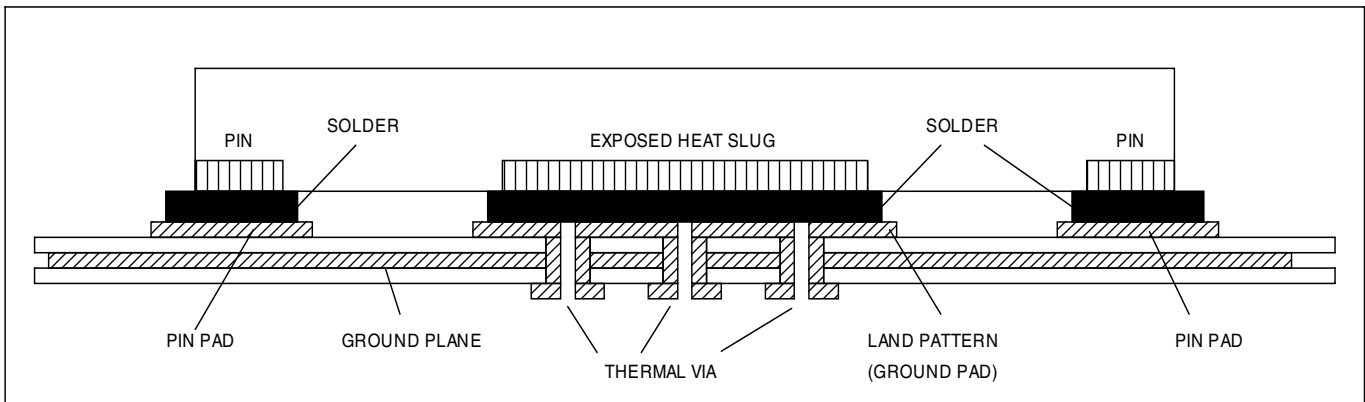

FIGURE 3. P.C.ASSEMBLY FOR EXPOSED PAD THERMAL RELEASE PATH –SIDE VIEW (DRAWING NOT TO SCALE)

TERMINATION FOR 3.3V LVPECL OUTPUTS

The clock layout topology shown below is a typical termination for LVPECL outputs. The two different layouts mentioned are recommended only as guidelines.

FOUT and nFOUT are low impedance follower outputs that generate ECL/LVPECL compatible outputs. Therefore, terminating resistors (DC current path to ground) or current sources must be used for functionality. These outputs are designed to drive

50Ω transmission lines. Matched impedance techniques should be used to maximize operating frequency and minimize signal distortion. *Figures 4A and 4B* show two different layouts which are recommended only as guidelines. Other suitable clock layouts may exist and it would be recommended that the board designers simulate to guarantee compatibility across all printed circuit and clock component process variations.

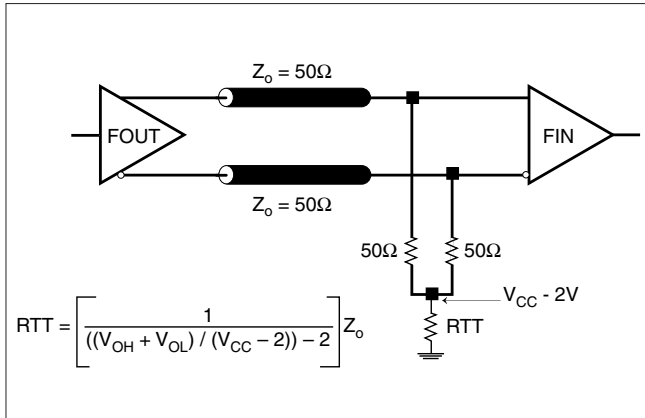

FIGURE 4A. LVPECL OUTPUT TERMINATION

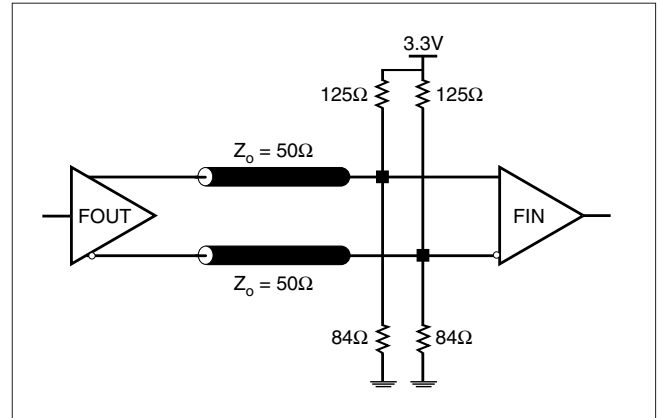

FIGURE 4B. LVPECL OUTPUT TERMINATION

TERMINATION FOR 2.5V LVPECL OUTPUTS

Figure 5A and Figure 5B show examples of termination for 2.5V LVPECL driver. These terminations are equivalent to terminating 50Ω to $V_{cc} - 2V$. For $V_{cc} = 2.5V$, the $V_{cc} - 2V$ is very close to ground

level. The R3 in Figure 5B can be eliminated and the termination is shown in Figure 5C.

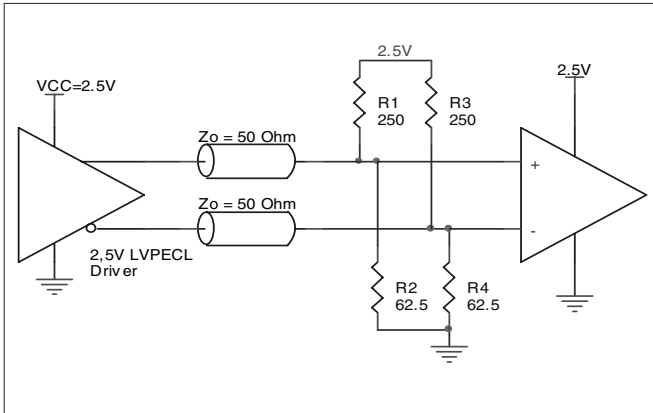

FIGURE 5A. 2.5V LVPECL DRIVER TERMINATION EXAMPLE

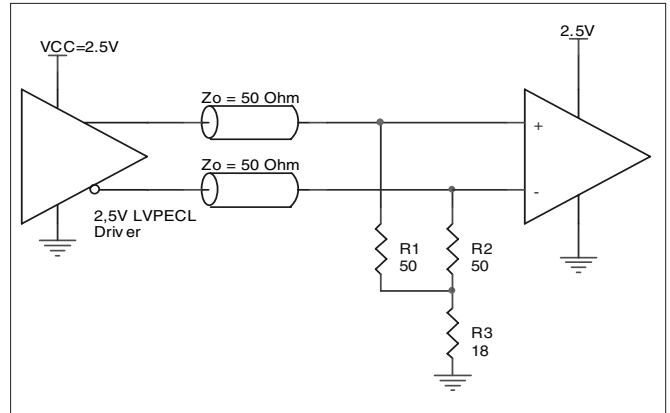

FIGURE 5B. 2.5V LVPECL DRIVER TERMINATION EXAMPLE

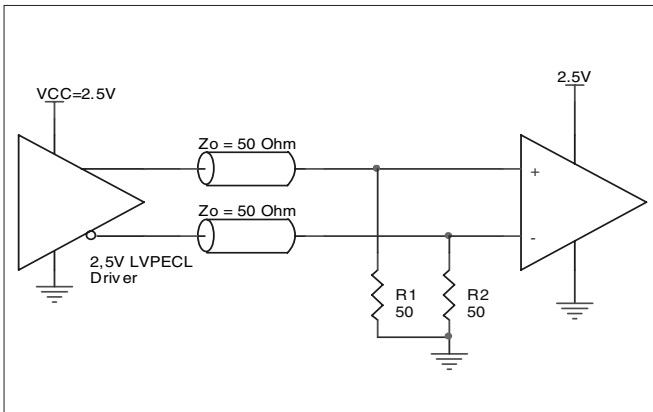

FIGURE 5C. 2.5V LVPECL TERMINATION EXAMPLE

POWER CONSIDERATIONS

This section provides information on power dissipation and junction temperature for the ICS853S12I. Equations and example calculations are also provided.

1. Power Dissipation.

The total power dissipation for the ICS853S12I is the sum of the core power plus the power dissipated in the load(s). The following is the power dissipation for $V_{CC} = 3.3V + 5\% = 3.465V$, which gives worst case results.

NOTE: Please refer to Section 3 for details on calculating power dissipated in the load.

- Power (core)_{MAX} = $V_{CC,MAX} * I_{EE,MAX} = 3.465V * 137mA = 474.7mW$
- Power (outputs)_{MAX} = **32mW/Loaded Output pair**
If all outputs are loaded, the total power is $12 * 32mW = 384mW$

Total Power_{MAX} (3.465V, with all outputs switching) = $474.7mW + 384mW = 858.7mW$

2. Junction Temperature.

Junction temperature, T_j , is the temperature at the junction of the bond wire and bond pad and directly affects the reliability of the device. The maximum recommended junction temperature for HiPerClockS™ devices is 125°C.

The equation for T_j is as follows: $T_j = \theta_{JA} * Pd_{total} + T_A$

T_j = Junction Temperature

θ_{JA} = Junction-to-Ambient Thermal Resistance

Pd_{total} = Total Device Power Dissipation (example calculation is in section 1 above)

T_A = Ambient Temperature

In order to calculate junction temperature, the appropriate junction-to-ambient thermal resistance θ_{JA} must be used. Assuming no air flow and a multi-layer board, the appropriate value is 42.7°C/W per Table 6 below.

Therefore, T_j for an ambient temperature of 85°C with all outputs switching is:
 $85°C + 0.859W * 42.7°C/W = 121.7°C$. This is below the limit of 125°C.

This calculation is only an example. T_j will obviously vary depending on the number of loaded outputs, supply voltage, air flow, and the type of board (single layer or multi-layer).

TABLE 6. THERMAL RESISTANCE θ_{JA} FOR 32 LEAD VFQFN, FORCED CONVECTION

θ_{JA} vs. Air Flow (Meter per Second)			
	0	1	2.5
Multi-Layer PCB, JEDEC Standard Test Boards	42.7°C/W	37.3°C/W	33.5°C/W

3. Calculations and Equations.

The purpose of this section is to derive the power dissipated into the load.

LVPECL output driver circuit and termination are shown in *Figure 6*.

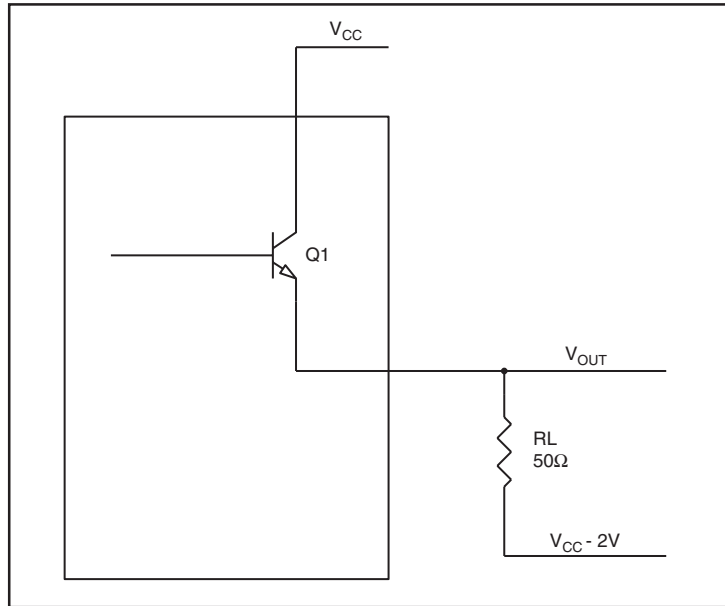

FIGURE 6. LVPECL DRIVER CIRCUIT AND TERMINATION

To calculate worst case power dissipation into the load, use the following equations which assume a 50Ω load, and a termination voltage of $V_{CC} - 2V$.

- For logic high, $V_{OUT} = V_{OH_MAX} = V_{CC_MAX} - 0.8V$

$$(V_{CC_MAX} - V_{OH_MAX}) = 0.8V$$

- For logic low, $V_{OUT} = V_{OL_MAX} = V_{CC_MAX} - 1.6V$

$$(V_{CC_MAX} - V_{OL_MAX}) = 1.6V$$

Pd_H is power dissipation when the output drives high.

Pd_L is the power dissipation when the output drives low.

$$Pd_H = [(V_{OH_MAX} - (V_{CC_MAX} - 2V))/R_L] * (V_{CC_MAX} - V_{OH_MAX}) = [(2V - (V_{CC_MAX} - V_{OH_MAX}))/R_L] * (V_{CC_MAX} - V_{OH_MAX}) = [(2V - 0.8V)/50\Omega] * 0.8V = 19.2mW$$

$$Pd_L = [(V_{OL_MAX} - (V_{CC_MAX} - 2V))/R_L] * (V_{CC_MAX} - V_{OL_MAX}) = [(2V - (V_{CC_MAX} - V_{OL_MAX}))/R_L] * (V_{CC_MAX} - V_{OL_MAX}) = [(2V - 1.6V)/50\Omega] * 1.6V = 12.8mW$$

Total Power Dissipation per output pair = $Pd_H + Pd_L = 32mW$

RELIABILITY INFORMATION

TABLE 7. θ_{JA} vs. AIR FLOW TABLE FOR 32 LEAD VFQFN

θ_{JA} vs. Air Flow (Meter per Second)			
	0	1	2.5
Multi-Layer PCB, JEDEC Standard Test Boards	42.7°C/W	37.3°C/W	33.5°C/W

TRANSISTOR COUNT

The transistor count for ICS853S12I is: 475

PACKAGE OUTLINE - K SUFFIX FOR 32 LEAD VFQFN

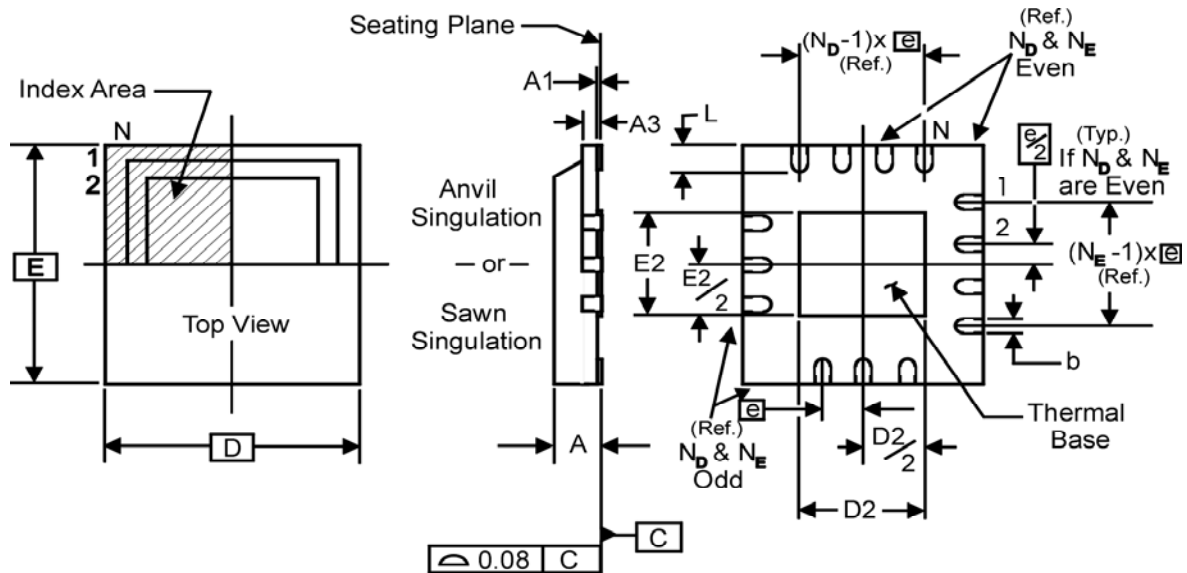

NOTE: The following package mechanical drawing is a generic drawing that applies to any pin count VFQFN package. This drawing is not intended to convey the actual pin count or pin layout of

this device. The pin count and pinout are shown on the front page. The package dimensions are in Table 8 below.

TABLE 8. PACKAGE DIMENSIONS

JEDEC VARIATION ALL DIMENSIONS IN MILLIMETERS			
SYMBOL	VHHD-2		
	MINIMUM	NOMINAL	MAXIMUM
N	32		
A	0.80	--	1.00
A1	0	--	0.05
A3	0.25 Ref.		
b	0.18	0.25	0.30
N _D			8
N _E			8
D	5.00 BASIC		
D2	1.25	2.25	3.25
E	5.00 BASIC		
E2	1.25	2.25	3.25
e	0.50 BASIC		
L	0.30	0.40	0.50

Reference Document: JEDEC Publication 95, MO-220

TABLE 9. ORDERING INFORMATION

Part/Order Number	Marking	Package	Shipping Packaging	Temperature
853S12AKILF	ICS53S12AIL	32 Lead "Lead-Free" VFQFN	Tray	-40°C to 85°C
853S12AKILFT	ICS53S12AIL	32 Lead "Lead-Free" VFQFN	1000 Tape & Reel	-40°C to 85°C

NOTE: Parts that are ordered with an "LF" suffix to the part number are the Pb-Free configuration and are RoHS compliant.

While the information presented herein has been checked for both accuracy and reliability, Integrated Device Technology, Incorporated (IDT) assumes no responsibility for either its use or for infringement of any patents or other rights of third parties, which would result from its use. No other circuits, patents, or licenses are implied. This product is intended for use in normal commercial and industrial applications. Any other applications such as those requiring high reliability or other extraordinary environmental requirements are not recommended without additional processing by IDT. IDT reserves the right to change any circuitry or specifications without notice. IDT does not authorize or warrant any IDT product for use in life support devices or critical medical instruments.

Innovate with IDT and accelerate your future networks. Contact:
www.IDT.com

For Sales

800-345-7015 (inside USA)
+408-284-8200 (outside USA)
Fax: 408-284-2775
www.IDT.com/go/contactIDT

For Tech Support

netcom@idt.com
+480-763-2056

Corporate Headquarters

Integrated Device Technology, Inc.
6024 Silver Creek Valley Road
San Jose, CA 95138
United States
800-345-7015 (inside USA)
+408-284-8200 (outside USA)

