



Chipsmall Limited consists of a professional team with an average of over 10 year of expertise in the distribution of electronic components. Based in Hongkong, we have already established firm and mutual-benefit business relationships with customers from,Europe,America and south Asia,supplying obsolete and hard-to-find components to meet their specific needs.

With the principle of “Quality Parts,Customers Priority,Honest Operation,and Considerate Service”,our business mainly focus on the distribution of electronic components. Line cards we deal with include Microchip,ALPS,ROHM,Xilinx,Pulse,ON,Everlight and Freescale. Main products comprise IC,Modules,Potentiometer,IC Socket,Relay,Connector.Our parts cover such applications as commercial,industrial, and automotives areas.

We are looking forward to setting up business relationship with you and hope to provide you with the best service and solution. Let us make a better world for our industry!



Contact us

Tel: +86-755-8981 8866 Fax: +86-755-8427 6832

Email & Skype: info@chipsmall.com Web: www.chipsmall.com

Address: A1208, Overseas Decoration Building, #122 Zhenhua RD., Futian, Shenzhen, China



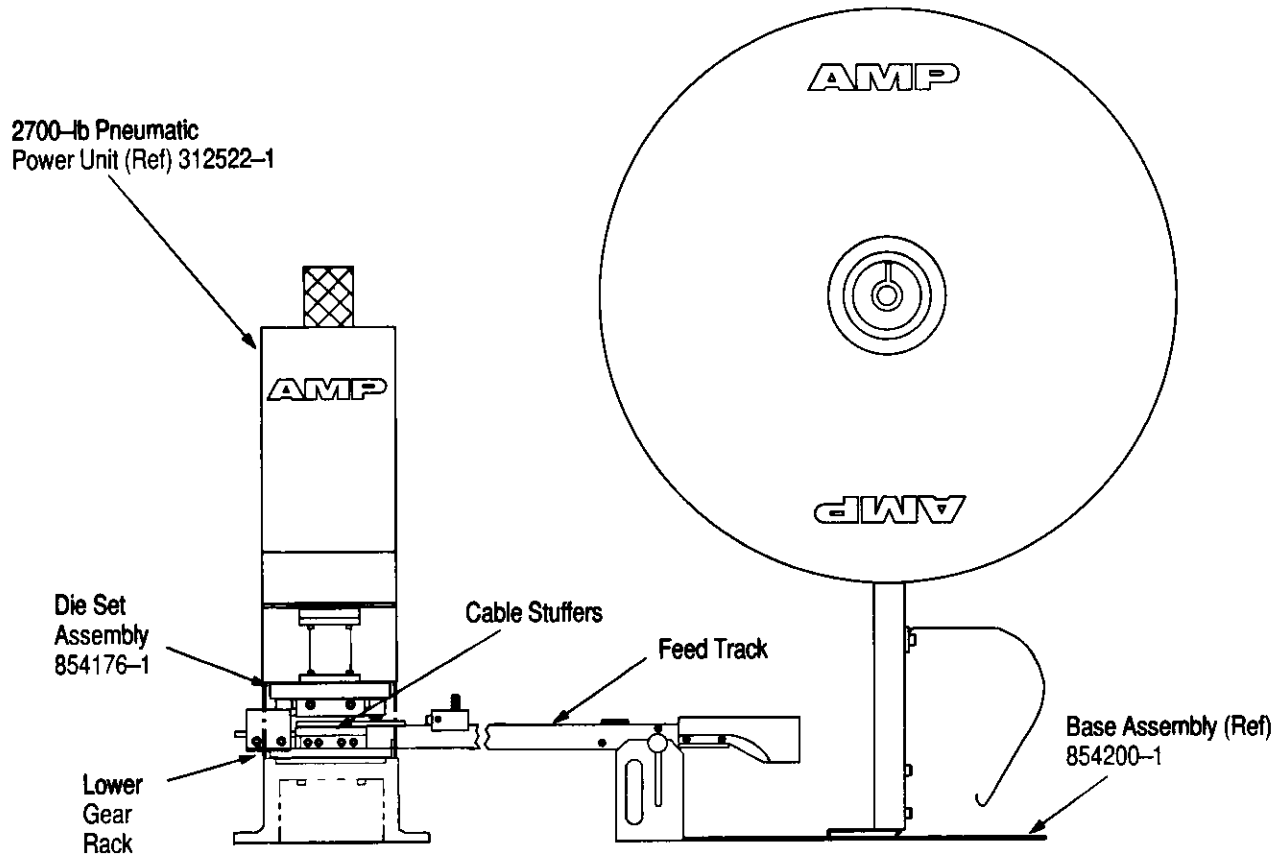

Figure 1

1. INTRODUCTION

This instruction sheet covers the operation and maintenance of AMP* Die Set Assembly 854176-1 which is designed to terminate notched ribbon cable (18-26 AWG) in the AMP MTA-.156 Closed-End Receptacle Connectors listed in Figure 2. The die set assembly is used in either a manual applicator such as AMP Manual Applicator Assembly 58024-1, or in a power unit such as AMP 2700-lb Pneumatic Power Unit 312522-1. AMP Base Assembly 854200-1, which is attached to the die set assembly, holds the product reel and acts as a support for the feed track.

The tooling combination of Die Set Assembly 854176-1, Base Assembly 854200-1, and 2700-lb Power Unit 312522-1 is CE approved. Refer to Section 7, EUROPEAN REGULATORY INFORMATION. The noise levels generated by the combination of Die Set Assembly 854176-1 with the 2700-lb Pneumatic Power Unit 312522-1 is in the range of 83 to 86 dB.

Read these instructions carefully before terminating any connectors.

NOTE Dimensions are in millimeters [with inches in brackets].

Reasons for reissue are in Section 8, REVISION SUMMARY.

2. DESCRIPTION (Figure 1)

The die set assembly terminates unstripped wire in four types of MTA-.156 Closed-End Receptacle Connectors: connectors with locking ramp *without* polarizing tabs; connectors with locking ramp *with* polarizing tabs; connectors without locking ramp *without* polarizing tabs; and connectors without locking ramp *with* polarizing tabs. The connectors contain slotted contacts on 3.96-mm [.156-in.] centers. See Figure 2.

**MTA-156 Receptacle Connectors
(Closed-End Style Only)**

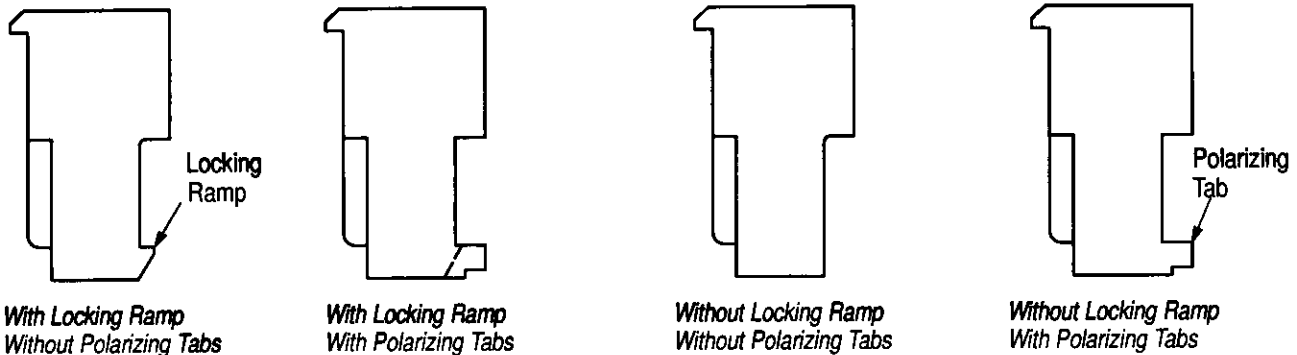

WIRE SIZE (AWG)	COLOR CODE	CLOSED-END STYLE WITH LOCKING RAMP		CLOSED-END STYLE WITHOUT LOCKING RAMP	
		WITHOUT POLARIZING TABS	WITH POLARIZING TABS	WITHOUT POLARIZING TABS	WITH POLARIZING TABS
18	Orange	640472	644878	640477	—
20	Yellow	640473	—	640478	—
22	Red	640474	644783	640479	644791
24	White	640475	—	640480	—
26	Blue	640476	—	640481	—

Die Set Assembly 854176-1 will also run equivalent loose-piece connectors.

Figure 2

The cables are terminated in the connector using the Insulation Displacement Contact (IDC) terminating technique, which is a method of inserting unstripped wire into a slotted contact beam to form a reliable electrical connection between the conductor and the contact.

After the die set assembly is installed into the manual applicator or power unit, it serves as a guide and support for the connector during termination. Features of the die set assembly (see Figure 1) and their functions are as follows:

Cable Stuffers — force individual wires between the two slotted beams of the contacts. Note that they provide support for the contact beams when applying insertion force on the wires.

Lower Gear Rack — acts as a stop for the connectors as they enter the insertion area.

Feed Track — serves as a storage area for connectors.

3. SETUP INSTRUCTIONS (Figure 3)

3.1. Base Assembly

1. Attach the reel support bracket to the base plate using two 1/4-20 x .50 L socket head cap screws.
2. Attach the guide plate to the reel support bracket using two 10-32 x .38 L socket head cap screws.
3. Secure the base assembly to a workbench using .25-in dia fasteners.

3.2. Die Set/Track Assembly in the 2700-Ib Power Unit 312522-1

DANGER

To avoid personal injury, disconnect power sources before installing the die set in the power unit.

1. Place the die set into the power unit.
2. Attach the lower die to the base of the power unit using four 8-32 x 1.25 L socket head cap screws.
3. Attach the ram adapter to ram and upper die using four 6-32 x .50 L socket head cap screws.
4. Attach the infeed guide to the track using two 6-32 x .25 L socket head cap screws.

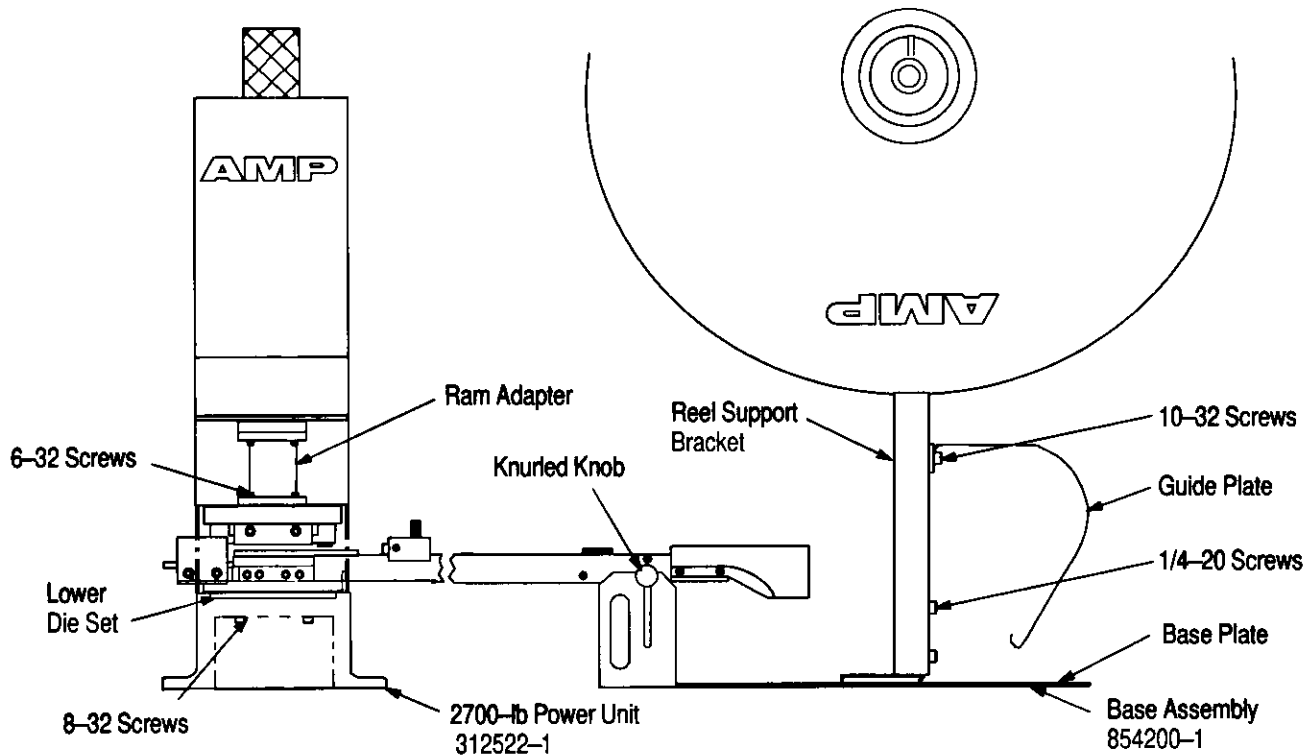

Figure 3

5. Loosen the knurled knob on the die set assembly and slide the die set assembly into the vertical slot on the base plate of base assembly 854200-1.

6. Tighten the knurled knob.

3.3. Die Set Assembly in the Manual Applicator Assembly 58024-1

1. Remove the ram adapter and two 6-32 x .88 L socket head cap screws from the die set assembly.

2. Place the die set assembly into the manual applicator assembly.

3. Attach the lower die to the base of the manual applicator using four 8-32 x .62 L socket head cap screws.

4. Attach the upper die to the ram using two 6-32 x .88 L socket head cap screws.

5. Loosen the knurled knob on the die set assembly in the vertical slot on the base plate of the base assembly 854200-1.

6. Secure the base assembly to a work bench using 6.35-mm [.25-in.] dia fasteners.

7. Tighten the knurled knob.

3.4. Product Loading

1. Remove the flange from the reel shaft of the base assembly.

2. Slide the reel onto the reel support shaft (mating face of connector should face the operator). The holes in the reel should engage the adjustable reel brake.

3. Unreel some product around the stock guide of the base assembly and into the infeed guide on the track assembly by twisting the product strip 1/4 turn so that the connectors are upright and facing the operator as they enter the feed track.

4. Continue to feed product into the track.

5. Note that by the track cover there is a slot located in the rear of the track. Separate the tape from the product and place the tape through the slot.

6. Place the tape over the top of the track pulley and through the opening in the base plate next to the knurled knob which secures the base assembly to the feed track.

7. Lift the upper gear rack (located to the left of the die assembly as the operator faces the machine) and adjust the lower gear rack to the desired position. The last position of the connector must be under the last inserter on the right hand side of the machine. When it is in proper location, release the upper gear rack.

8. Pull, by hand, on the tape which extends through the base plate to load the track with connectors.

9. Move the slide pawl over the connectors in the feed track until it reaches the limit of travel on the cable or is at the end of the connectors loaded in the track. The pawl will engage against the end of the last available connector and the cable will maintain tension on the connectors in the track, thereby indexing them forward to the termination area as each terminated connector is removed.

3.5. Manual and Pneumatic Unit Adjustments

1. Determine the wire size and select the appropriate connector. (Connectors are color-coded according to the wire sizes they accommodate.)
2. Using a small knife, cut off wire retainers (strain relief). This will provide a clear view for inspecting the connector for a properly terminated wire in the contact. See AMP Application Specification 114-1020.
3. Place a connector in feed track assembly and make a test termination using procedure described in Section 4, TERMINATING PROCEDURE, Steps 1 through 5.
4. Pull the connector out of the front of the track.

5. Inspect the termination according to Figure 4 and AMP Application Specification 114-1020.

3.6. Wire Insertion Depth Adjustment

A. Manually-Powered Units

1. **Wire Too Deep In Contact Slot** — Turn the adjusting ring **CLOCKWISE** to the desired position.
2. **Wire Not Deep Enough In Contact Slot** — Turn the adjusting ring **COUNTERCLOCKWISE** to the desired position.
3. When proper insertion depth has been attained, tighten the adjusting ring setscrew to prevent accidental movement of the adjusting ring.

B. Pneumatically-Powered Units

1. **Wire Too Deep In Contact Slot** — Turn the depth adjusting knob **CLOCKWISE** to the desired position. Each graduation represents a .0254-mm [.001-in.] change in insertion depth.
2. **Wire Not Deep Enough In Contact Slot** — Turn the depth adjusting knob **COUNTERCLOCKWISE** to the desired position. Each graduation represents a .0254-mm [.001-in.] change in insertion depth.
3. When proper insertion depth has been attained, tighten the adjusting knob setscrew to prevent accidental movement of the adjusting knob.

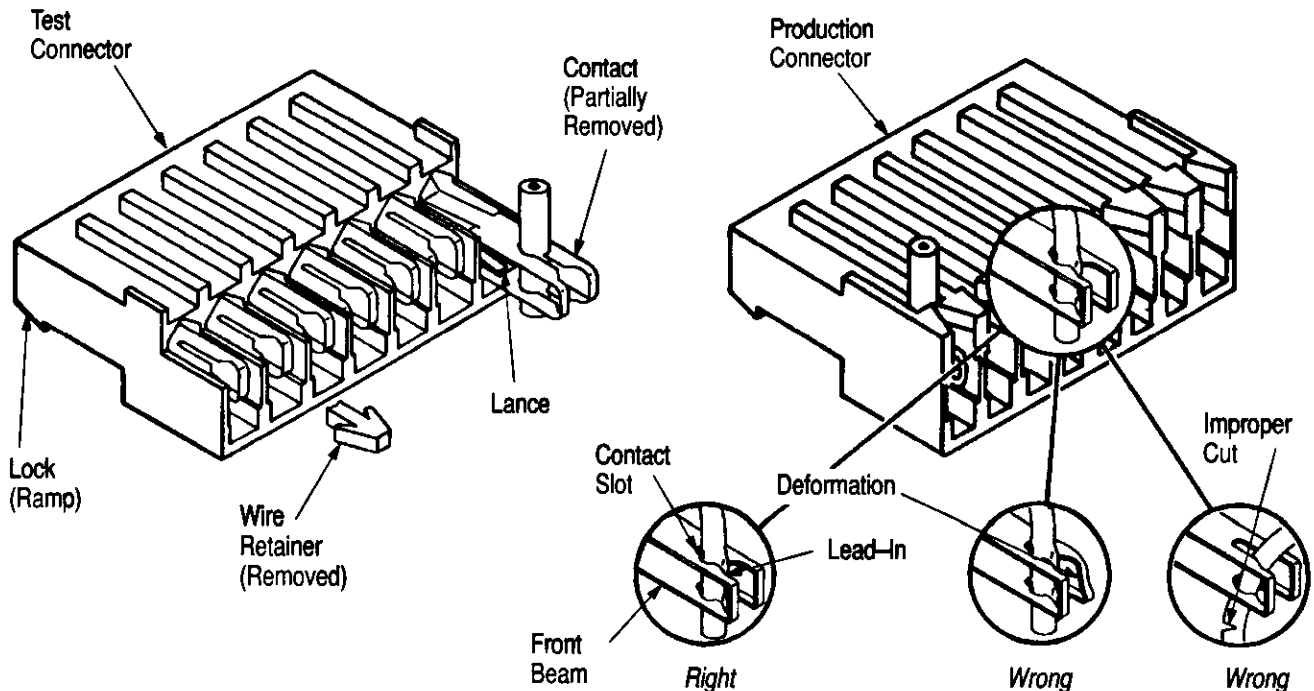

Figure 4

3.7. Feed Adjustment

The lower gear rack should be placed in the position corresponding to the connector being used.

Two adjustment lock screws are located at the far left side of the track assembly facing front. These screws, the stop block, and the lower gear rack control the positioning of the connectors under the stuffers. The following observations are made when the feed adjustment is properly aligned.

1. The far right end of the connector is aligned under the far right position of the stuffer assembly.
2. No movement of the connector housing occurs as the stuffer assembly is lowered.
3. No contact between the stuffer assembly and the connector housing occurs.

4. TERMINATING PROCEDURE

1. Insert a notched cable into the insertion area, making sure that the sides of the cable are kept within the sides of the connector housing.
2. Lower the top assembly (depress the foot switch for pneumatic units) to crimp the cable to the contacts. Make sure that manual units are lowered fully to their stops.
3. Raise the top assemblies and pull the cable/connector straight out of the insertion area, pulling toward the front of the unit.

NOTE

The next connector is automatically advanced into the insertion area. When withdrawing the connector/cable assembly, the hinged gate rotates forward and allows the assembly to be withdrawn. As the gate returns to its initial position, the next connector is advanced into the termination area.

4. Repeat Steps 1 through 3 until either the pawl slide is fully returned (closest to the termination area) or the connectors are finished.
5. Inspect terminations according to Figure 4 and AMP Application Specification 114-1020.

5. TOOL MAINTENANCE/INSPECTION

The following procedures were established by AMP Quality Control Engineers to provide documented maintenance and inspection procedures to ensure the quality and reliability of Die Set Assembly 854176-1.

AMP recommends that the die set assembly be inspected immediately upon its arrival at your facility to ensure that it has not been damaged during transit. Customer-replaceable parts are listed on AMP Customer Drawing 854176, which is provided in the documentation package accompanying the dies. A complete inventory should be stocked and controlled to prevent lost time when replacement of parts is necessary.

Order replacement parts through your AMP representative, or call 1-800-526-5142, or send a facsimile of your purchase order to:

CUSTOMER SERVICE (38-35)
AMP INCORPORATED
P.O. BOX 3608
HARRISBURG, PA 17105-3608

5.1. Daily Maintenance

It is recommended that each operator be made aware of — and responsible for — the following steps of daily maintenance:

1. Remove dust, moisture, and other contaminants with a clean brush or a soft, lint-free cloth. Do NOT use objects that could damage the feed track assembly.
2. Make sure all components are in place and properly secured.

5.2. Periodic Inspection

Regular inspections should be performed by quality control personnel. A record of scheduled inspections should remain with the assembly and/or be supplied to supervisory personnel. Though recommendations call for at least one inspection a month, the inspection frequency should be based on the amount of use, working conditions, operator training and skill, and established company standards. These inspections should include a visual inspection and should be performed in the sequence shown in Paragraph 5.3, Visual Inspection.

5.3. Visual Inspection

1. Remove any accumulated film with a suitable commercial degreaser that will not affect paint or plastic material.
2. Make sure all components are in place and are properly secured.
3. Check for chipped, cracked, worn, or broken areas. If damage is evident, repair is necessary. See Section 6, REPAIR.

6. REPAIR

Parts other than those specified in AMP Customer Drawing 854176 must be replaced by AMP to ensure the quality and reliability of the die set assembly. When repair is necessary, return the die set assembly with a written description of the problem to:

CUSTOMER REPAIR (01-12)
AMP INCORPORATED
1523 NORTH 4TH STREET
HARRISBURG, PA 17102-1604

7. EUROPEAN REGULATORY INFORMATION

A technical file document, as required by the Supply of Machinery (Safety) Regulations 1992, has been prepared for Die Set Assembly 854176-1 and 2700-lb Power Unit 312522-1.

These components are CE approved only in conjunction with each other, and are *not* approved separately. Refer to Drawing 356767 for the Declaration of Conformity.

8. REVISION SUMMARY

Since the previous release of this instruction sheet, the following changes were made per EC 0990-1110-96:

- Added European Regulatory Information
- Added noise levels of die and tooling combination
- Added MTA-.156 Receptacle Connectors to Figure 2
- Removed loose-piece connectors from Figure 2
- Updated format
- Added metric units