



Chipsmall Limited consists of a professional team with an average of over 10 year of expertise in the distribution of electronic components. Based in Hongkong, we have already established firm and mutual-benefit business relationships with customers from,Europe,America and south Asia,supplying obsolete and hard-to-find components to meet their specific needs.

With the principle of “Quality Parts,Customers Priority,Honest Operation,and Considerate Service”,our business mainly focus on the distribution of electronic components. Line cards we deal with include Microchip,ALPS,ROHM,Xilinx,Pulse,ON,Everlight and Freescale. Main products comprise IC,Modules,Potentiometer,IC Socket,Relay,Connector.Our parts cover such applications as commercial,industrial, and automotives areas.

We are looking forward to setting up business relationship with you and hope to provide you with the best service and solution. Let us make a better world for our industry!



Contact us

Tel: +86-755-8981 8866 Fax: +86-755-8427 6832

Email & Skype: info@chipsmall.com Web: www.chipsmall.com

Address: A1208, Overseas Decoration Building, #122 Zhenhua RD., Futian, Shenzhen, China





GENERAL DESCRIPTION



The ICS855011 is a low skew, high performance 1-to-2 Differential-to-2.5V/3.3V CML Fanout Buffer and a member of the HiPerClockS™ family of High Performance Clock Solutions from IDT. The ICS855011 is characterized to operate from either a 2.5V or a 3.3V power supply. Guaranteed output and part-to-part skew characteristics make the ICS855011 ideal for those clock distribution applications demanding well defined performance and repeatability.

FEATURES

- Two differential 2.5V/3.3V CML outputs
- One differential PCLK, nPCLK input pair
- PCLK, nPCLK pair can accept the following differential input levels: LVPECL, LVDS, CML, SSTL
- Output frequency: >3GHz
- Translates any single ended input signal to 3.3V LVPECL levels with resistor bias on nPCLK input
- Output skew: 5ps (typical)
- Part-to-part skew: TBD
- Propagation delay: 242ps (typical)
- Operating voltage supply range:
 $V_{CC} = 2.375V$ to $3.8V$, $V_{EE} = 0V$
- -40°C to 85°C ambient operating temperature
- Available in both standard (RoHS5) and lead-free (RoHS 6) packages

BLOCK DIAGRAM

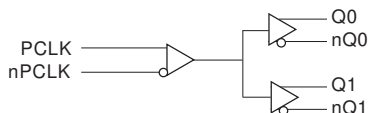

PIN ASSIGNMENT

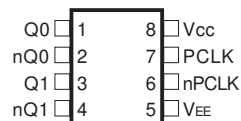

ICS855011
8-Lead TSSOP
 3mm x 3mm x 0.95mm package body
G Package
 Top View

The Preliminary Information presented herein represents a product in pre-production. The noted characteristics are based on initial product characterization and/or qualification. Integrated Device Technology, Incorporated (IDT) reserves the right to change any circuitry or specifications without notice.



TABLE 1. PIN DESCRIPTIONS

Number	Name	Type		Description
1, 2	Q0, nQ0	Output		Differential output pair. CML interface levels.
3, 4	Q1, nQ1	Output		Differential output pair. CML interface levels.
5	V _{EE}	Power		Negative supply pin.
6	nPCLK	Input	Pullup	Inverting differential LVPECL clock input.
7	PCLK	Input	Pulldown	Non-inverting LVPECL differential clock input.
8	V _{CC}	Power		Positive supply pin.

NOTE: *Pullup and Pulldown* refer to internal input resistors. See Table 2, Pin Characteristics, for typical values.

TABLE 2. PIN CHARACTERISTICS

Symbol	Parameter	Test Conditions	Minimum	Typical	Maximum	Units
R _{PULLDOWN}	Input Pulldown Resistor			75		kΩ
R _{PULLUP}	Input Pullup Resistor			75		kΩ



ABSOLUTE MAXIMUM RATINGS

Supply Voltage, V_{CC}	4.6V (CML mode, $V_{EE} = 0$)
Inputs, V_I	-0.5V to $V_{CC} + 0.5$ V
Outputs, I_O	
Continuous Current	20mA
Surge Current	40mA
Operating Temperature Range, T_A	-40°C to +85°C
Storage Temperature, T_{STG}	-65°C to 150°C
Package Thermal Impedance, θ_{JA} (Junction-to-Ambient)	101.7°C/W (0 m/s)

NOTE: Stresses beyond those listed under Absolute Maximum Ratings may cause permanent damage to the device. These ratings are stress specifications only. Functional operation of product at these conditions or any conditions beyond those listed in the *DC Characteristics* or *AC Characteristics* is not implied. Exposure to absolute maximum rating conditions for extended periods may affect product reliability.

TABLE 3A. POWER SUPPLY DC CHARACTERISTICS, $V_{CC} = 2.375$ V TO 3.8V; $V_{EE} = 0$ V

Symbol	Parameter	Test Conditions	Minimum	Typical	Maximum	Units
V_{CC}	Positive Supply Voltage		2.375	3.3	3.8	V
I_{EE}	Power Supply Current			50		mA

TABLE 3B. LVPECL DC CHARACTERISTICS, $V_{CC} = 2.375$ V TO 3.8V; $V_{EE} = 0$ V

Symbol	Parameter	Test Conditions	Minimum	Typical	Maximum	Units
I_{IH}	Input High Current	PCLK	$V_{CC} = V_{IN} = 3.8$ V		150	μ A
		nPCLK	$V_{CC} = V_{IN} = 3.8$ V		5	μ A
I_{IL}	Input Low Current	PCLK	$V_{CC} = 3.8$ V, $V_{IN} = 0$ V	-5		μ A
		nPCLK	$V_{CC} = 3.8$ V, $V_{IN} = 0$ V	-150		μ A
V_{PP}	Peak-to-Peak Input Voltage		0.3		1	V
V_{CMR}	Common Mode Input Voltage; NOTE 1, 2		$V_{EE} + 1.5$		V_{CC}	V

NOTE 1: Common mode voltage is defined as V_{IH} .

NOTE 2: For single ended applications, the maximum input voltage for PCLK and nPCLK is $V_{CC} + 0.3$ V.

TABLE 3C. CML DC CHARACTERISTICS, $V_{CC} = 2.375$ V TO 3.8V; $V_{EE} = 0$ V

Symbol	Parameter	Conditions	Minimum	Typical	Maximum	Units
V_{OH}	Output High Voltage; NOTE 1		$V_{CC} - 0.020$	$V_{CC} - 0.010$	V_{CC}	V
V_{OUT}	Output Voltage Swing		325	400		mV
V_{DIFF_OUT}	Differential Output Voltage Swing		650	800		mV
R_{OUT}	Output Source Impedance		40	50	60	Ω

NOTE 1: Outputs terminated with 100 Ω across differential output pair.

TABLE 4. AC CHARACTERISTICS, $V_{CC} = 0V$; $V_{EE} = -3.8V$ TO $-2.375V$ OR $V_{CC} = 2.375$ TO $3.8V$; $V_{EE} = 0V$

Symbol	Parameter	Condition	Minimum	Typical	Maximum	Units
f_{MAX}	Output Frequency			>3		GHz
t_{PD}	Propagation Delay; (Differential); NOTE 1			242		ps
$t_{sk(o)}$	Output Skew; NOTE 2, 4			5		ps
$t_{sk(pp)}$	Part-to-Part Skew; NOTE 3, 4			TBD		ps
t_R/t_F	Output Rise/Fall Time	20% to 80%		140		ps
odc	Output Duty Cycle			50		ps

All parameters characterized at $\leq 1GHz$ unless otherwise noted.

$R_L = 100\Omega$ after each output pair.

NOTE 1: Measured from the differential input crossing point to the differential output crossing point.

NOTE 2: Defined as skew between outputs at the same supply voltage and with equal load conditions.

Measured at the output differential cross points.

NOTE 3: Defined as skew between outputs on different devices operating at the same supply voltages and with equal load conditions. Using the same type of inputs on each device, the outputs are measured at the differential cross points.

NOTE 4: This parameter is defined in accordance with JEDEC Standard 65.



PARAMETER MEASUREMENT INFORMATION

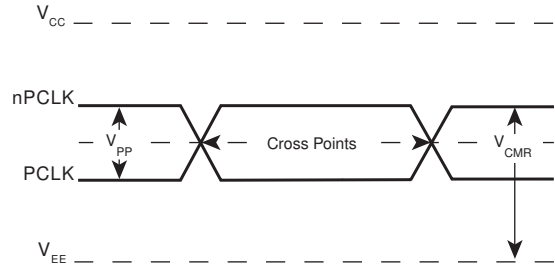
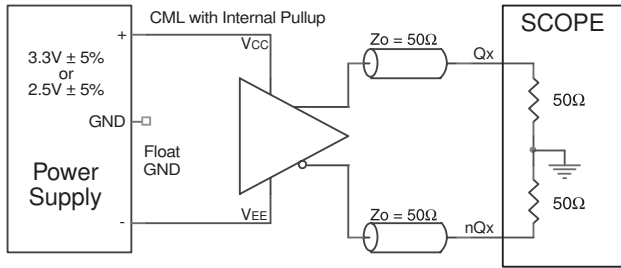

OUTPUT LOAD AC TEST CIRCUIT

DIFFERENTIAL INPUT LEVEL

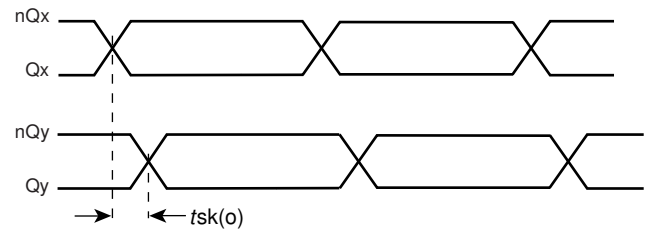
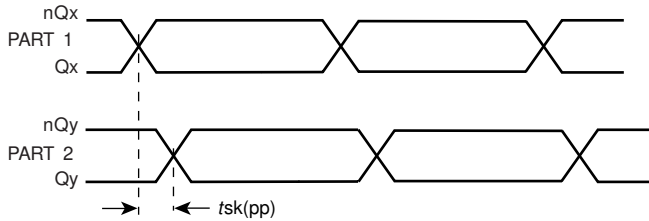

PART-TO-PART SKEW

OUTPUT SKEW

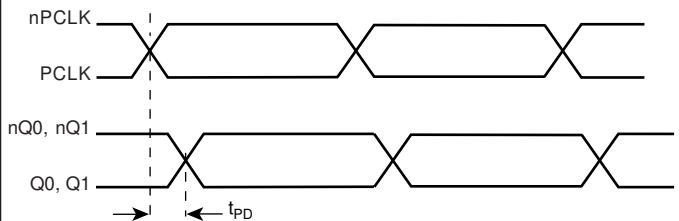
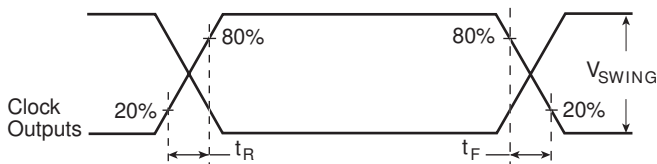

OUTPUT RISE/FALL TIME

PROPAGATION DELAY

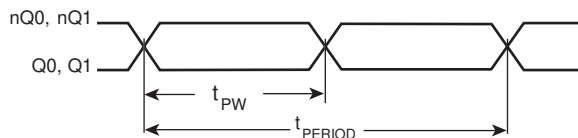

$$\text{odc} = \frac{t_{PW}}{t_{PERIOD}} \times 100\%$$

OUTPUT DUTY CYCLE/PULSE WIDTH/PERIOD

APPLICATION INFORMATION

WIRING THE DIFFERENTIAL INPUT TO ACCEPT SINGLE ENDED LEVELS

Figure 1 shows how the differential input can be wired to accept single ended levels. The reference voltage $V_{REF} = V_{CC}/2$ is generated by the bias resistors R1, R2 and C1. This bias circuit should be located as close as possible to the input pin. The ratio

of R1 and R2 might need to be adjusted to position the V_{REF} in the center of the input voltage swing. For example, if the input clock swing is only 2.5V and $V_{CC} = 3.3V$, V_{REF} should be 1.25V and $R2/R1 = 0.609$.

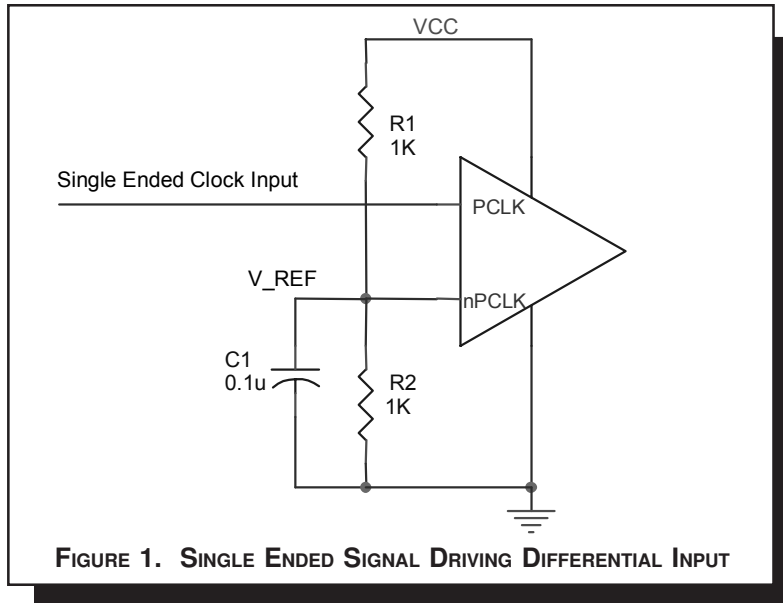



LVPECL CLOCK INPUT INTERFACE

The PCLK /nPCLK accepts LVPECL, CML, SSTL and other differential signals. Both V_{SWING} and V_{OH} must meet the V_{PP} and V_{CMR} input requirements. Figures 2A to 2F show interface examples for the HiPerClockS PCLK/nPCLK input driven by the most common driver types. The input interfaces suggested

here are examples only. If the driver is from another vendor, use their termination recommendation. Please consult with the vendor of the driver component to confirm the driver termination requirements.

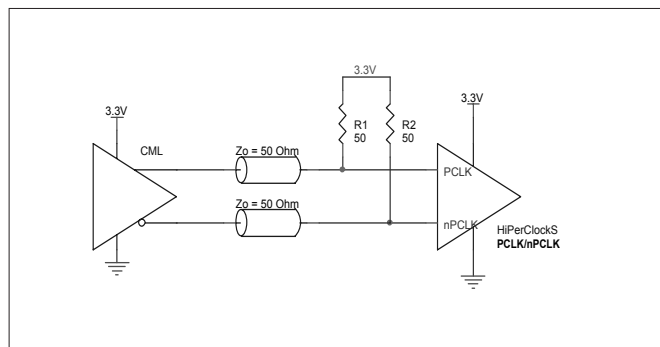

FIGURE 2A. HiPerClockS PCLK/nPCLK INPUT DRIVEN BY AN OPEN COLLECTOR CML DRIVER

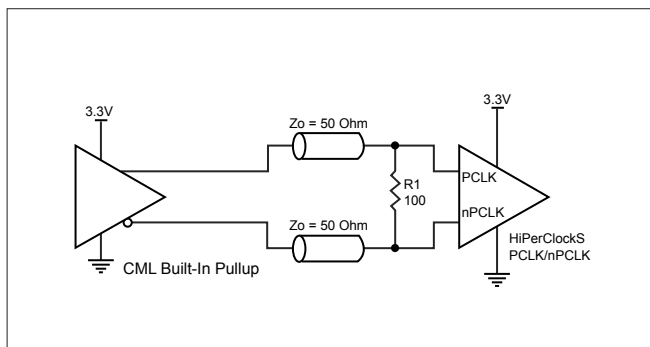

FIGURE 2B. HiPerClockS PCLK/nPCLK INPUT DRIVEN BY A BUILT-IN PULLUP CML DRIVER

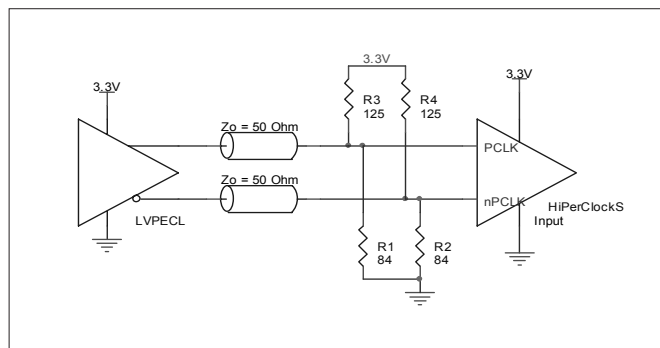

FIGURE 2C. HiPerClockS PCLK/nPCLK INPUT DRIVEN BY A 3.3V LVPECL DRIVER

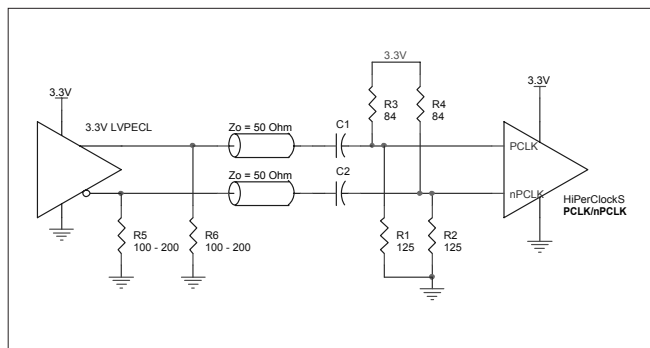

FIGURE 2D. HiPerClockS PCLK/nPCLK INPUT DRIVEN BY A 3.3V LVPECL DRIVER WITH AC COUPLE

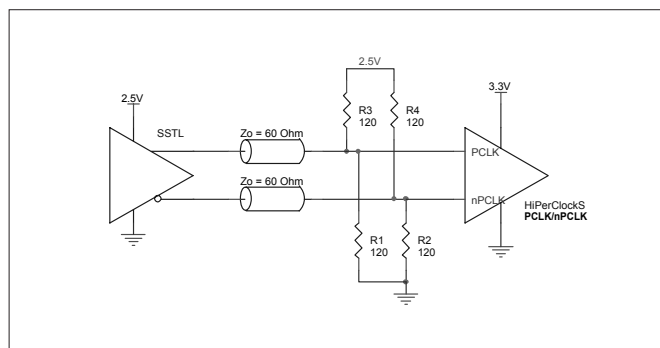

FIGURE 2E. HiPerClockS PCLK/nPCLK INPUT DRIVEN BY AN SSTL DRIVER

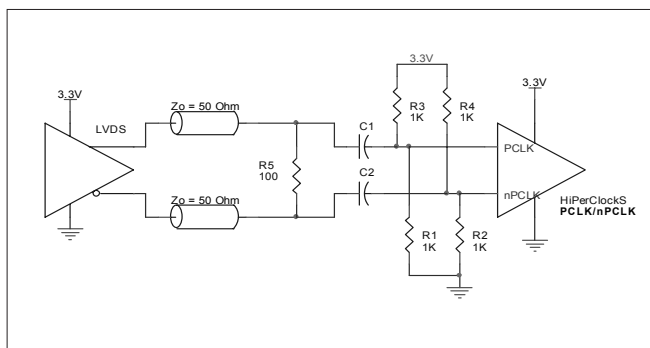

FIGURE 2F. HiPerClockS PCLK/nPCLK INPUT DRIVEN BY A 3.3V LVDS DRIVER



RELIABILITY INFORMATION

TABLE 6. θ_{JA} VS. AIR FLOW TABLE FOR 8 LEAD TSSOP

θ_{JA} by Velocity (Meters per Second)			
	0	1	2
Multi-Layer PCB, JEDEC Standard Test Boards	101.7°C/W	90.5°C/W	89.8°C/W

TRANSISTOR COUNT

The transistor count for ICS855011 is: 109



PRELIMINARY

ICS855011
 LOW SKEW, 1-TO-2

DIFFERENTIAL-TO-2.5V/3.3V CML FANOUT BUFFER

PACKAGE OUTLINE - G SUFFIX FOR 8 LEAD TSSOP

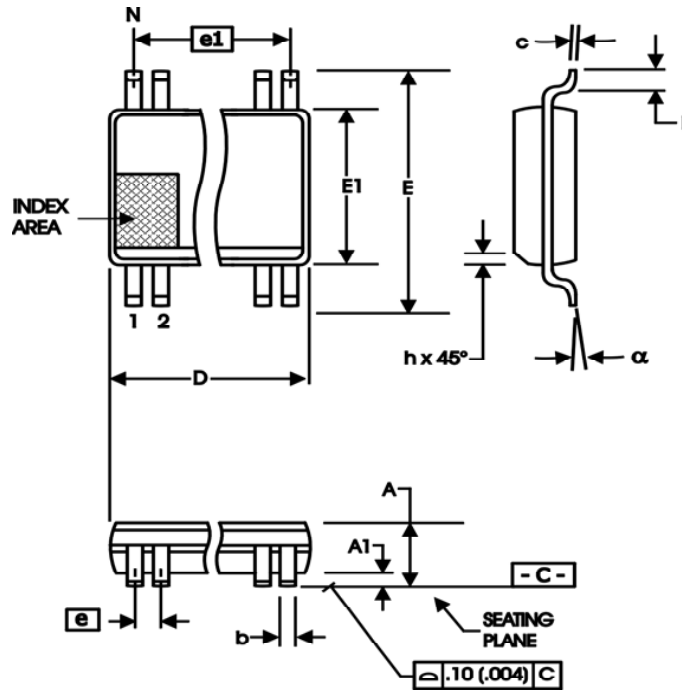

TABLE 7. PACKAGE DIMENSIONS

SYMBOL	Millimeters	
	Minimum	Maximum
N	8	
A	--	1.10
A1	0	0.15
A2	0.79	0.97
b	0.22	0.38
c	0.08	0.23
D	3.00 BASIC	
E	4.90 BASIC	
E1	3.00 BASIC	
e	0.65 BASIC	
e1	1.95 BASIC	
L	0.40	0.80
α	0°	8°
aaa	--	0.10

Reference Document: JEDEC Publication 95, MO-187



TABLE 8. ORDERING INFORMATION

Part/Order Number	Marking	Package	Shipping Packaging	Temperature
ICS855011AG	011A	8 lead TSSOP	tube	-40°C to 85°C
ICS855011AGT	011A	8 lead TSSOP	2500 tape & reel	-40°C to 85°C
ICS855011AGLF	11AL	8 lead "Lead-Free" TSSOP	tube	-40°C to 85°C
ICS855011AGLFT	11AL	8 lead "Lead-Free" TSSOP	2500 tape & reel	-40°C to 85°C

NOTE: Parts that are ordered with an "LF" suffix to the part number are the Pb-Free configuration and are RoHS compliant.