



Chipsmall Limited consists of a professional team with an average of over 10 year of expertise in the distribution of electronic components. Based in Hongkong, we have already established firm and mutual-benefit business relationships with customers from,Europe,America and south Asia,supplying obsolete and hard-to-find components to meet their specific needs.

With the principle of “Quality Parts,Customers Priority,Honest Operation,and Considerate Service”,our business mainly focus on the distribution of electronic components. Line cards we deal with include Microchip,ALPS,ROHM,Xilinx,Pulse,ON,Everlight and Freescale. Main products comprise IC,Modules,Potentiometer,IC Socket,Relay,Connector.Our parts cover such applications as commercial,industrial, and automotives areas.

We are looking forward to setting up business relationship with you and hope to provide you with the best service and solution. Let us make a better world for our industry!



Contact us

Tel: +86-755-8981 8866 Fax: +86-755-8427 6832

Email & Skype: info@chipsmall.com Web: www.chipsmall.com

Address: A1208, Overseas Decoration Building, #122 Zhenhua RD., Futian, Shenzhen, China



LEAD-FREE/P/N 85973-001LF PRESS FIT

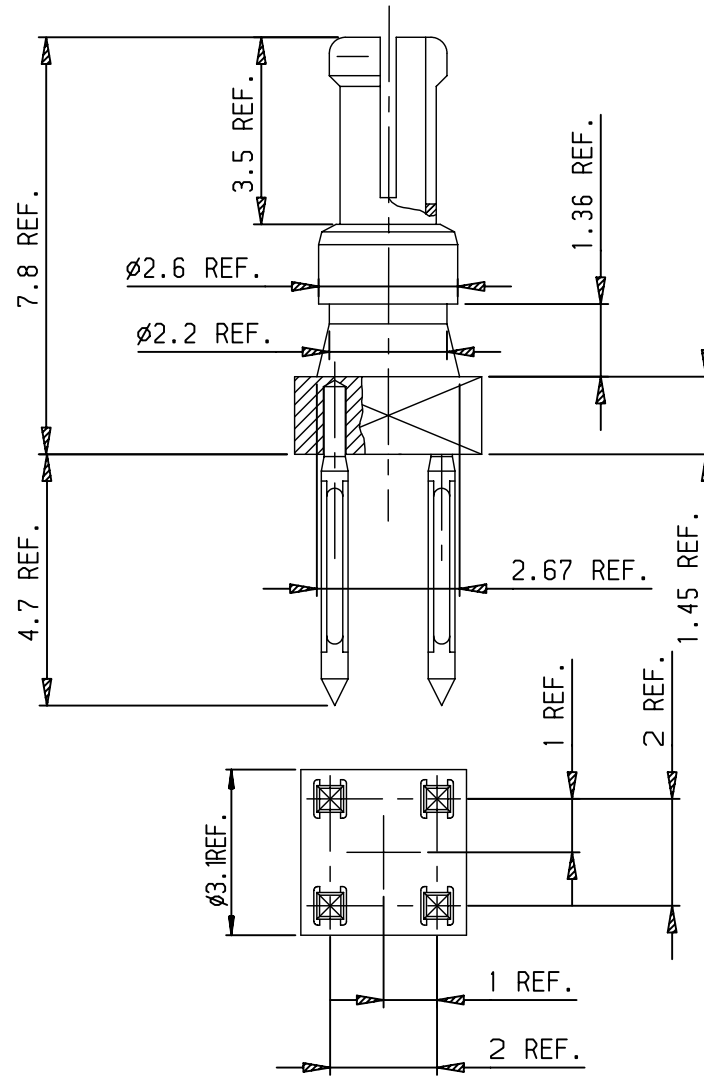

NOTES:

1. THIS PRODUCT WITH "LF" SUFFIX MEETS EUROPEAN UNION DIRECTIVES AND OTHER COUNTRY REGULATIONS AS DESCRIBED IN GS -22-008.
2. THE PRODUCT IS NOT INTENDED TO BE EXPOSED TO A MANUFACTURING SOLDER PROCESS.
3. PACKAGING SPEC: SEE GS-14-920

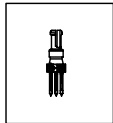

Scale 1:1

European Views

www.fciconnect.com		surface ISO 1302	<input checked="" type="checkbox"/>	tolerance std ISO 406 ISO 1101	projection 	mm
TOLERANCES UNLESS OTHERWISE SPECIFIED						
Dr	GOISNARD	2006/06/03	ANGULAR	LINEAR	0.X ±0.1	size A3
Eng	GOISNARD	2006/03/06	0.XX ±0.1	0.XXX ±0.1	Scale 10	
Chr	LEGARE	2006/03/06	0.XX* ±2*		ECN LS08-0057	
Appr	LEGARE	2006/03/06	Product family		METRAL	Spec ref -
		title MINI POWER MALE INSERT			dwg no 85973	Rev. F
catalog no		-			CUSTOMER	sheet 1 of 2

rev	ecn no	dr	date
D	-	-	-
-	LS07-0214	LGO	2007/08/20
F	LS08-0057	LGO	2008/02/18
-	-	-	-
-	-	-	-
-	-	-	-

LEAD-FREE P/N	DIM T	DIM A	TAILTYPE
85973-002LF	2.00	9.80	SOLDER
85973-003LF	2.50	10.30	SOLDER
85973-004LF	3.00	10.80	SOLDER

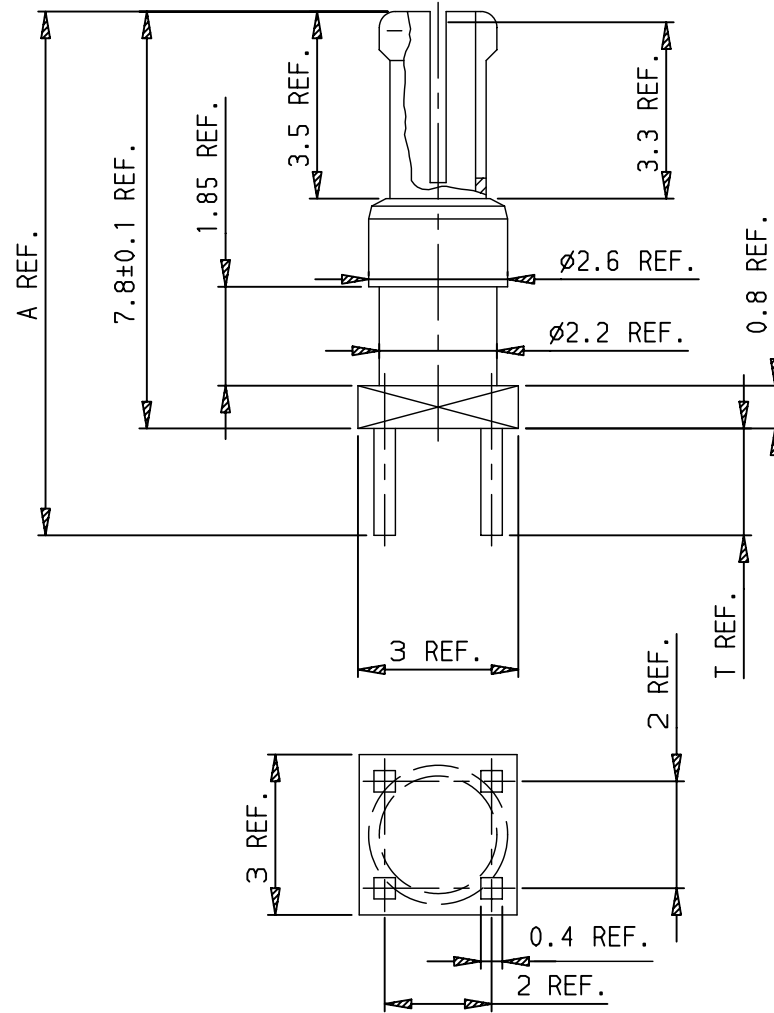

NOTES:

1. THIS PRODUCT WITH "LF" SUFFIX MEETS EUROPEAN UNION DIRECTIVES AND OTHER COUNTRY REGULATIONS AS DESCRIBED IN GS-22-008.
2. THE PRODUCT WILL WITHSTAND EXPOSURE TO 260 DEGREE PEAK TEMPERATURE TO 30 SECONDS IN A WAVE SOLDER APPLICATION WITH A 1.6 mm MINIMUM THICK PCB
3. PACKAGING SPEC: SEE GS-14-920

European Views

www.fciconnect.com		surface ISO 1302 <input checked="" type="checkbox"/>	tolerance std ISO 406 ISO 1101	projection 	mm
TOLERANCES UNLESS OTHERWISE SPECIFIED					
Dr	GOISNARD	2006/03/06	ANGULAR	0.X ±0.1	size A3
Eng	GOISNARD	2006/03/06	LINEAR	0.XX ±0.1	Scale 10
Chr	LEGARE	2006/03/06	0.XX' ±2'	0.XXX ±0.1	ECN LS07-0057
Appr	LEGARE	2006/03/06	Product family	METRAL	Spec ref -
		title STR STB HDR		dwg no 85973	Rev. F
catalog no		-		CUSTOMER	sheet 2 of 2