



Chipsmall Limited consists of a professional team with an average of over 10 year of expertise in the distribution of electronic components. Based in Hongkong, we have already established firm and mutual-benefit business relationships with customers from,Europe,America and south Asia,supplying obsolete and hard-to-find components to meet their specific needs.

With the principle of "Quality Parts,Customers Priority,Honest Operation,and Considerate Service",our business mainly focus on the distribution of electronic components. Line cards we deal with include Microchip,ALPS,ROHM,Xilinx,Pulse,ON,Everlight and Freescale. Main products comprise IC,Modules,Potentiometer,IC Socket,Relay,Connector.Our parts cover such applications as commercial,industrial, and automotives areas.

We are looking forward to setting up business relationship with you and hope to provide you with the best service and solution. Let us make a better world for our industry!



## Contact us

Tel: +86-755-8981 8866 Fax: +86-755-8427 6832

Email & Skype: info@chipsmall.com Web: www.chipsmall.com

Address: A1208, Overseas Decoration Building, #122 Zhenhua RD., Futian, Shenzhen, China



1

2

3

4

NOTES:

- 1-Material:phosphor bronze,thickness 0.20
- 2-Finish on contact area:see table  
finish on termination:bright tin lead over nickel
- 3-Wire range:24 to 28 AWG
- 4-Max outer dia of wire insulator:1.02 mm
- 5-Current carrying capacity per contact:
  - 3.Amps max when crimped to #24 AWG
  - 2 Amps max when crimped to #26 AWG
  - 1 Amps max when crimped to #28 AWG
- 6-After 5 insertions into connector, contact retention must be 5 pounds axial load min
- 7-When contact is crimped to 24 AWG,the insulation support crimped height must be 1.78 mm max to ensure a proper insertion into housing
- 6-Packaging:BOX of 500 contacts

NOTE : ROHS INFORMATIONS

The LF products meet European union directives and other country regulations as described in GS-22-008  
 Terminations plating spec : 2um Nickel min + 2um Sn min  
 Packaging Spec : see GS-14-920

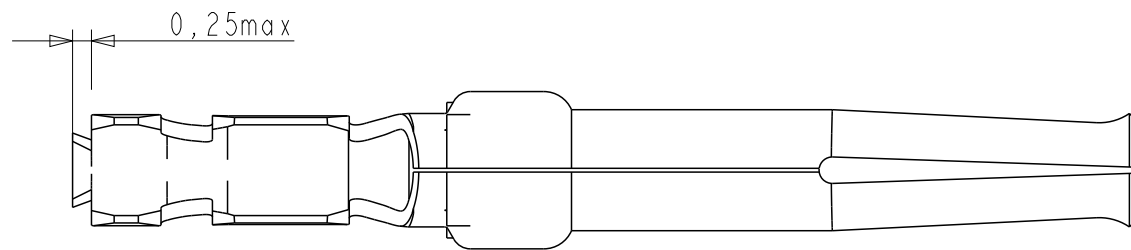

A

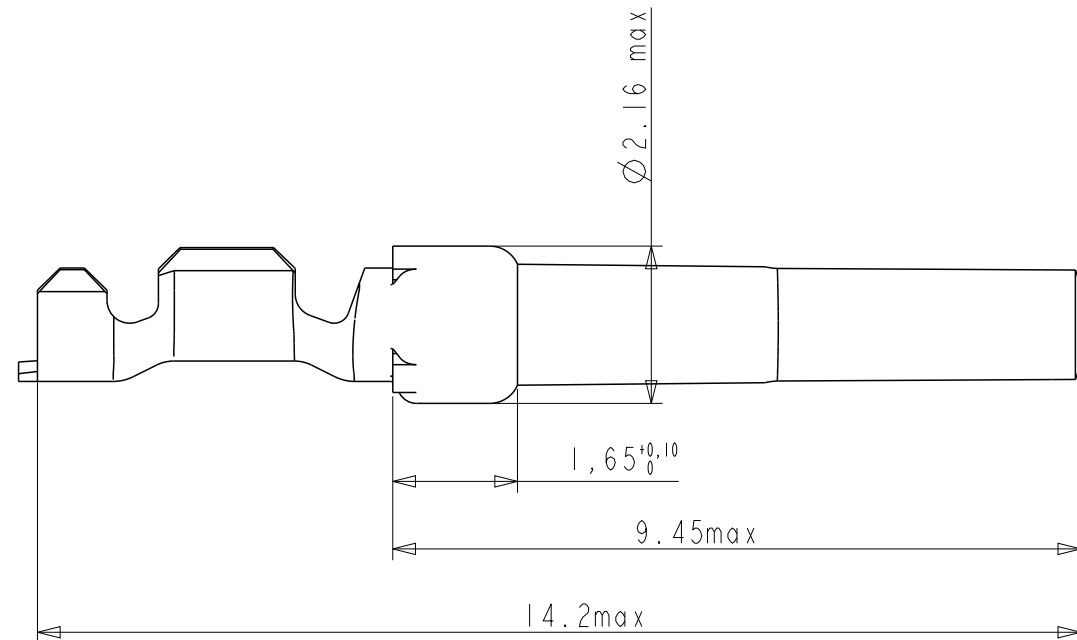

B

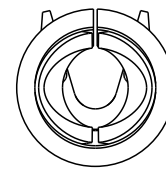

A

B

C

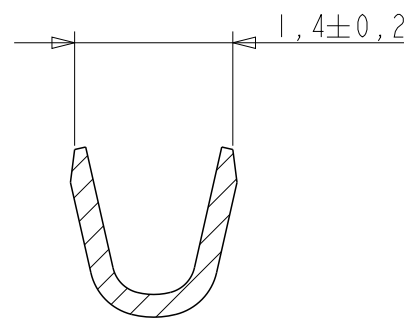

SECTION A-A  
SCALE 15/1

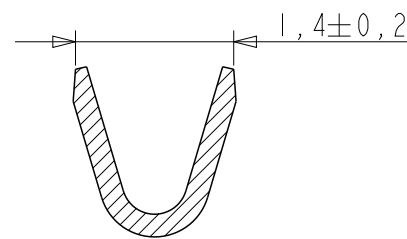

SECTION B-B  
SCALE 15/1

C

D

CORE RANGE	
8656351067LF	0.4μ Au / GXT
8656351067	0.4μ Au / GXT
8656351065LF	0.76μ Au / GXT
8656351065	0.76μ Au / GXT
8656351066LF	1.25μ Au / GXT
8656351066	1.25μ Au / GXT
PART NUMBER	Plating

www.fciconnect.com		surface - <input checked="" type="checkbox"/> ISO 1302	tolerance std ISO 406 ISO 1101	projection	mm
TOLERANCES UNLESS OTHERWISE SPECIFIED					
Dr	C JARRY	28/01/97	ANGULAR	size A3	Scale 10/1
Eng			LINEAR	ECN	111-0003
Chr			0° ±2°	Product family	8656 Spec ref
Appr					
			FCi		Rev. G
			title CRIMP CONTACTS		dwg no C01-8656-1533
			catalog no		CUSTOMER sheet 1 of 1

rev	ecn no	dr	date
B	LS05-006	MPE	25-06-05
C	LS06-0196	MPE	27/11/2006
D	LS08-0127	MPE	2008/05/13
E	109-0152	AMR	2009-07-27
F	110-0070	AMR	2010-03-09
G	111-0003	AMR	2011-01-06
-	-	-	-

1

2

3



Copyright FCI.