



Chipsmall Limited consists of a professional team with an average of over 10 year of expertise in the distribution of electronic components. Based in Hongkong, we have already established firm and mutual-benefit business relationships with customers from,Europe,America and south Asia,supplying obsolete and hard-to-find components to meet their specific needs.

With the principle of "Quality Parts,Customers Priority,Honest Operation,and Considerate Service",our business mainly focus on the distribution of electronic components. Line cards we deal with include Microchip,ALPS,ROHM,Xilinx,Pulse,ON,Everlight and Freescale. Main products comprise IC,Modules,Potentiometer,IC Socket,Relay,Connector.Our parts cover such applications as commercial,industrial, and automotives areas.

We are looking forward to setting up business relationship with you and hope to provide you with the best service and solution. Let us make a better world for our industry!



Contact us

Tel: +86-755-8981 8866 Fax: +86-755-8427 6832

Email & Skype: info@chipsmall.com Web: www.chipsmall.com

Address: A1208, Overseas Decoration Building, #122 Zhenhua RD., Futian, Shenzhen, China



GENERAL DESCRIPTION

The 8705I is a highly versatile 1:8 Differential-to-LVCMOS/ LVTTTL Clock Generator. The 8705I has two selectable clock inputs. The CLK1, nCLK1 pair can accept most standard differential input levels. The single ended CLK0 input accepts LVCMOS or LVTTTL input levels. The 8705I has a fully integrated PLL and can be configured as zero delay buffer, multiplier or divider and has an input and output frequency range of 15.625MHz to 250MHz. The reference divider, feedback divider and output divider are each programmable, thereby allowing for the following output-to-input frequency ratios: 8:1, 4:1, 2:1, 1:1, 1:2, 1:4, 1:8. The external feedback allows the device to achieve “zero delay” between the input clock and the output clocks. The PLL_SEL pin can be used to bypass the PLL for system test and debug purposes. In bypass mode, the reference clock is routed around the PLL and into the internal output dividers.

FEATURES

- Eight LVCMOS/LVTTTL outputs, 7Ω typical output impedance
- Selectable CLK1, nCLK1 or LVCMOS/LVTTTL clock inputs
- CLK1, nCLK1 pair can accept the following differential input levels: LVPECL, LVDS, LVHSTL, HCSL, SSTL
- CLK0 input accepts LVCMOS or LVTTTL input levels
- Output frequency range: 15.625MHz to 250MHz
- Input frequency range: 15.625MHz to 250MHz
- VCO range: 250MHz to 500MHz
- External feedback for “zero delay” clock regeneration with configurable frequencies
- Programmable dividers allow for the following output-to-input frequency ratios: 8:1, 4:1, 2:1, 1:1, 1:2, 1:4, 1:8
- Fully integrated PLL
- Cycle-to-cycle jitter: 45ps (maximum)
- Output skew: CLK0, 65ps (maximum)
CLK1, nCLK1, 55ps (maximum)
- Static Phase Offset: 25 ±125ps (maximum), CLK0
- Full 3.3V or 2.5V operating supply
- Lead-Free package available
- -40°C to 85°C ambient operating temperature
- **Not Recommended for New Designs**
For new designs, contact IDT.

BLOCK DIAGRAM

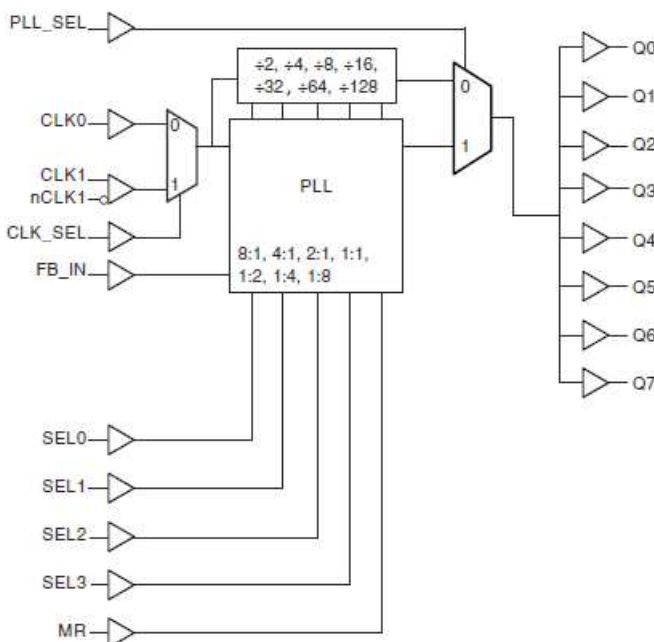

PIN ASSIGNMENT

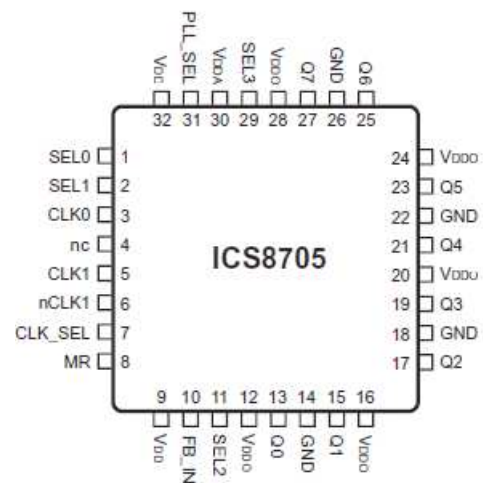

32-Lead LQFP

7mm x 7mm x 1.4 mm
Y Package
Top View

TABLE 1. PIN DESCRIPTIONS

Number	Name	Type		Description
1, 2	SEL0, SEL1	Input	Pulldown	Determines output divider values in Table 3. LVCMOS/LVTTL interface levels.
3	CLK0	Input	Pulldown	Clock input. LVCMOS/LVTTL interface levels.
4	nc			No connect.
5	CLK1	Input	Pulldown	Non-inverting differential clock input.
6	nCLK1	Input	Pullup	Inverting differential clock input.
7	CLK_SEL	Input	Pulldown	Clock select input. When HIGH, selects differential CLK1, nCLK1. When LOW, selects LVCMOS CLK0. LVCMOS/LVTTL interface levels.
8	MR	Input	Pulldown	Active HIGH Master Reset. When logic HIGH, the internal dividers are reset causing the outputs to go low. When logic LOW, the internal dividers and the outputs are enabled. LVCMOS/LVTTL interface levels
9, 32	V _{DD}	Power		Core supply pins.
10	FB_IN	Input	Pulldown	LVCMOS/LVTTL feedback input to phase detector for regenerating clocks with “zero delay”. Connect to one of the outputs. LVCMOS/LVTTL interface levels.
11	SEL2	Input	Pulldown	Determines output divider values in Table 3. LVCMOS/LVTTL interface levels.
12, 16, 20, 24, 28	V _{DDO}	Power		Output supply pins.
13, 15, 17, 19, 21, 23, 25, 27	Q0, Q1, Q2, Q3, Q4, Q5, Q6, Q7	Output		Clock output. 7 Ω typical output impedance. LVCMOS/LVTTL interface levels.
14, 18, 22, 26	GND	Power		Power supply ground.
29	SEL3	Input	Pulldown	Determines output divider values in Table 3. LVCMOS/LVTTL interface levels.
30	V _{DDA}	Power		Analog supply pin.
31	PLL_SEL	Input	Pullup	Selects between the PLL and reference clock as input to the dividers. When LOW, selects the reference clock (PLL Bypass). When HIGH, selects PLL (PLL Enabled). LVCMOS/LVTTL interface levels.

NOTE: *Pullup* and *Pulldown* refer to internal input resistors. See Table 2, Pin Characteristics, for typical values.

TABLE 2. PIN CHARACTERISTICS

Symbol	Parameter	Test Conditions	Minimum	Typical	Maximum	Units
C _{IN}	Input Capacitance			4		pF
R _{PULLUP}	Input Pullup Resistor			51		K Ω
R _{PULLDOWN}	Input Pulldown Resistor			51		K Ω
C _{PD}	Power Dissipation Capacitance (per output)	V _{DD} , V _{DDA} , V _{DDO} = 3.465V		23		pF
R _{OUT}	Output Impedance		5	7	12	Ω

TABLE 3A. PLL ENABLE FUNCTION TABLE

Inputs					Outputs PLL_SEL = 1 PLL Enable Mode
SEL3	SEL2	SEL1	SEL0	Reference Frequency Range (MHz)	Q0:Q7
0	0	0	0	125 - 250	÷ 1
0	0	0	1	62.5 - 125	÷ 1
0	0	1	0	31.25 - 62.5	÷ 1
0	0	1	1	15.625 - 31.25	÷ 1
0	1	0	0	125 - 250	÷ 2
0	1	0	1	62.5 - 125	÷ 2
0	1	1	0	31.25 - 62.5	÷ 2
0	1	1	1	125 - 250	÷ 4
1	0	0	0	62.5 - 125	÷ 4
1	0	0	1	125 - 250	÷ 8
1	0	1	0	62.5 - 125	x 2
1	0	1	1	31.25 - 62.5	x 2
1	1	0	0	15.625 - 31.25	x 2
1	1	0	1	31.25 - 62.5	x 4
1	1	1	0	15.625 - 31.25	x 4
1	1	1	1	15.625 - 31.25	x 8

TABLE 3B. PLL BYPASS FUNCTION TABLE

Inputs				Outputs PLL_SEL = 0 PLL Bypass Mode
SEL3	SEL2	SEL1	SEL0	Q0:Q7
0	0	0	0	÷ 8
0	0	0	1	÷ 8
0	0	1	0	÷ 8
0	0	1	1	÷ 16
0	1	0	0	÷ 16
0	1	0	1	÷ 16
0	1	1	0	÷ 32
0	1	1	1	÷ 32
1	0	0	0	÷ 64
1	0	0	1	÷ 128
1	0	1	0	÷ 4
1	0	1	1	÷ 4
1	1	0	0	÷ 8
1	1	0	1	÷ 2
1	1	1	0	÷ 4
1	1	1	1	÷ 2

ABSOLUTE MAXIMUM RATINGS

Supply Voltage, V_{DD}	4.6V
Inputs, V_I	-0.5V to $V_{DD} + 0.5V$
Outputs, V_O	-0.5V to $V_{DDO} + 0.5V$
Package Thermal Impedance, θ_{JA}	47.9°C/W (0 lfpm)
Storage Temperature, T_{STG}	-65°C to 150°C

NOTE: Stresses beyond those listed under Absolute Maximum Ratings may cause permanent damage to the device. These ratings are stress specifications only. Functional operation of product at these conditions or any conditions beyond those listed in the *DC Characteristics* or *AC Characteristics* is not implied. Exposure to absolute maximum rating conditions for extended periods may affect product reliability.

TABLE 4A. POWER SUPPLY DC CHARACTERISTICS, $V_{DD} = V_{DDA} = V_{DDO} = 3.3V \pm 5\%$, $T_A = -40^\circ\text{C}$ TO 85°C

Symbol	Parameter	Test Conditions	Minimum	Typical	Maximum	Units
V_{DD}	Core Supply Voltage		3.135	3.3	3.465	V
V_{DDA}	Analog Supply Voltage		3.135	3.3	3.465	V
V_{DDO}	Output Supply Voltage		3.135	3.3	3.465	V
I_{DD}	Power Supply Current				90	mA
I_{DDA}	Analog Supply Current				15	mA
I_{DDO}	Output Supply Current				20	mA

TABLE 4B. LVCMOS / LVTTTL DC CHARACTERISTICS, $V_{DD} = V_{DDA} = V_{DDO} = 3.3V \pm 5\%$, $T_A = -40^\circ\text{C}$ TO 85°C

Symbol	Parameter	Test Conditions	Minimum	Typical	Maximum	Units
V_{IH}	Input High Voltage	PLL_SEL, CLK_SEL, SEL0, SEL1, SEL2, SEL3, FB_IN, MR	2		$V_{DD} + 0.3$	V
		CLK0	2		$V_{DD} + 0.3$	V
V_{IL}	Input Low Voltage	PLL_SEL, CLK_SEL, SEL0, SEL1, SEL2, SEL3, FB_IN, MR	-0.3		0.8	V
		CLK0	-0.3		1.3	V
I_{IH}	Input High Current	CLK0, CLK_SEL, MR, FB_IN, SEL0, SEL1, SEL2, SEL3	$V_{DD} = V_{IN} = 3.465V$		150	μA
		PLL_SEL	$V_{DD} = V_{IN} = 3.465V$		5	μA
I_{IL}	Input Low Current	CLK0, CLK_SEL, MR, FB_IN, SEL0, SEL1, SEL2, SEL3	$V_{DD} = 3.465V, V_{IN} = 0V$	-5		μA
		PLL_SEL	$V_{DD} = 3.465V, V_{IN} = 0V$	-150		μA
V_{OH}	Output High Voltage; NOTE 1		2.6			V
V_{OL}	Output Low Voltage; NOTE 1				0.5	V

NOTE 1: Outputs terminated with 50Ω to $V_{DDO}/2$. In the Parameter Measurement Information section, see "3.3V Output Load Test Circuit" figure.

TABLE 4C. DIFFERENTIAL DC CHARACTERISTICS, $V_{DD} = V_{DDA} = V_{DDO} = 3.3V \pm 5\%$, $T_A = -40^\circ C$ TO $85^\circ C$

Symbol	Parameter	Test Conditions	Minimum	Typical	Maximum	Units
I_{IH}	Input High Current	CLK1	$V_{DD} = V_{IN} = 3.465V$		150	μA
		nCLK1	$V_{DD} = V_{IN} = 3.465V$		5	μA
I_{IL}	Input Low Current	CLK1	$V_{DD} = 3.465V, V_{IN} = 0V$	-5		μA
		nCLK1	$V_{DD} = 3.465V, V_{IN} = 0V$	-150		μA
V_{PP}	Peak-to-Peak Input Voltage		0.15		1.3	V
V_{CMR}	Common Mode Input Voltage; NOTE 1, 2		GND + 0.5		$V_{DD} - 0.85$	V

NOTE 1: Common mode voltage is defined as V_{IH} .

NOTE 2: For single ended applications, the maximum input voltage for CLK1, nCLK1 is $V_{DD} + 0.3V$.

TABLE 5A. AC CHARACTERISTICS, $V_{DD} = V_{DDA} = V_{DDO} = 3.3V \pm 5\%$, $T_A = -40^\circ C$ TO $85^\circ C$

Symbol	Parameter	Test Conditions	Minimum	Typical	Maximum	Units	
f_{MAX}	Output Frequency		15.625		250	MHz	
t_{pLH}	Propagation Delay, Low-to-High; NOTE 1	CLK0	PLL_SEL = 0V, $f \leq 250MHz, Qx \div 2$	5		7	ns
		CLK1, nCLK1	PLL_SEL = 0V, $f \leq 250MHz, Qx \div 2$	5		7.3	ns
$t(\theta)$	Static Phase Offset; NOTE 2, 4	CLK0	PLL_SEL = 3.3V, $f_{REF} \leq 200MHz, Qx \div 1$	-100	25	150	ps
		CLK1, nCLK1	PLL_SEL = 3.3V, $f_{REF} \leq 167MHz, Qx \div 1$	-15	+135	285	ps
			PLL_SEL = 3.3V, $f_{REF} = 200MHz, Qx \div 1$	-50	+100	250	ps
$t_{sk(o)}$	Output Skew; NOTE 3, 4	CLK0	PLL_SEL = 0V			65	ps
		CLK1, nCLK1	PLL_SEL = 0V			55	ps
$t_{jit(cc)}$	Cycle-to-Cycle Jitter; NOTE 4	$f_{OUT} > 40MHz$			45	ps	
t_L	PLL Lock Time				1	mS	
t_R	Output Rise Time		400		950	ps	
t_F	Output Fall Time		400		950	ps	
odc	Output Duty Cycle		43		57	%	

All parameters measured at f_{MAX} unless noted otherwise.

NOTE 1: Measured from the differential input crossing point to the output at $V_{DDO}/2$.

NOTE 2: Defined as the time difference between the input reference clock and the average feedback input signal when the PLL is locked and the input reference frequency is stable.

NOTE 3: Defined as skew between outputs at the same supply voltages and with equal load conditions. Measured at $V_{DDO}/2$.

NOTE 4: This parameter is defined in accordance with JEDEC Standard 65.

TABLE 4D. POWER SUPPLY DC CHARACTERISTICS, $V_{DD} = V_{DDA} = V_{DDO} = 2.5V \pm 5\%$, $T_A = -40^\circ\text{C}$ TO 85°C

Symbol	Parameter	Test Conditions	Minimum	Typical	Maximum	Units
V_{DD}	Core Supply Voltage		2.375	2.5	2.625	V
V_{DDA}	Analog Supply Voltage		2.375	2.5	2.625	V
V_{DDO}	Output Supply Voltage		2.375	2.5	2.625	V
I_{DD}	Power Supply Current				90	mA
I_{DDA}	Analog Supply Current				15	mA
I_{DDO}	Output Supply Current				20	mA

TABLE 4E. LVCMOS / LVTTTL DC CHARACTERISTICS, $V_{DD} = V_{DDA} = V_{DDO} = 2.5V \pm 5\%$, $T_A = -40^\circ\text{C}$ TO 85°C

Symbol	Parameter	Test Conditions	Minimum	Typical	Maximum	Units
V_{IH}	Input High Voltage	PLL_SEL, CLK_SEL, SEL0, SEL1, SEL2, SEL3, FB_IN, MR	2		$V_{DD} + 0.3$	V
		CLK0	2		$V_{DD} + 0.3$	V
V_{IL}	Input Low Voltage	PLL_SEL, CLK_SEL, SEL0, SEL1, SEL2, SEL3, FB_IN, MR	-0.3		0.8	V
		CLK0	-0.3		1.3	V
I_{IH}	Input High Current	CLK0, CLK_SEL, MR, FB_IN, SEL0, SEL1, SEL2, SEL3	$V_{DD} = V_{IN} = 2.625V$		150	μA
		PLL_SEL	$V_{DD} = V_{IN} = 2.625V$		5	μA
I_{IL}	Input Low Current	CLK0, CLK_SEL, MR, FB_IN, SEL0, SEL1, SEL2, SEL3	$V_{DD} = 2.625V, V_{IN} = 0V$	-5		μA
		PLL_SEL	$V_{DD} = 2.625V, V_{IN} = 0V$	-150		μA
V_{OH}	Output High Voltage; NOTE 1		1.8			V
V_{OL}	Output Low Voltage; NOTE 1				0.5	V

NOTE 1: Outputs terminated with 50Ω to $V_{DDO}/2$. In the Parameter Measurement Information section, see "2.5V Output Load Test Circuit" figure.

TABLE 4F. DIFFERENTIAL DC CHARACTERISTICS, $V_{DD} = V_{DDA} = V_{DDO} = 2.5V \pm 5\%$, $T_A = -40^\circ\text{C}$ TO 85°C

Symbol	Parameter	Test Conditions	Minimum	Typical	Maximum	Units
I_{IH}	Input High Current	CLK1	$V_{DD} = V_{IN} = 2.625V$		150	μA
		nCLK1	$V_{DD} = V_{IN} = 2.625V$		5	μA
I_{IL}	Input Low Current	CLK1	$V_{DD} = 2.625V, V_{IN} = 0V$	-5		μA
		nCLK1	$V_{DD} = 2.625V, V_{IN} = 0V$	-150		μA
V_{PP}	Peak-to-Peak Input Voltage		0.15		1.3	V
V_{CMR}	Common Mode Input Voltage; NOTE 1, 2		GND + 0.5		$V_{DD} - 0.85$	V

NOTE 1: Common mode voltage is defined as V_{IH} .

NOTE 2: For single ended applications, the maximum input voltage for CLK1, nCLK1 is $V_{DD} + 0.3V$.

TABLE 5B. AC CHARACTERISTICS, $V_{DD} = V_{DDA} = V_{DDO} = 2.5V \pm 5\%$, $T_A = -40^\circ C$ TO $85^\circ C$

Symbol	Parameter	Test Conditions	Minimum	Typical	Maximum	Units	
f_{MAX}	Output Frequency		15.625		250	MHz	
t_{pLH}	Propagation Delay, Low-to-High; NOTE 1	CLK0	PLL_SEL = 0V, $f \leq 250\text{MHz}$, $Q_x \div 2$	5		7	ns
		CLK1, nCLK1	PLL_SEL = 0V, $f \leq 250\text{MHz}$, $Q_x \div 2$	5		7.3	ns
$t(\emptyset)$	Static Phase Offset; NOTE 2, 4	CLK0	PLL_SEL = 2.5V, $f_{REF} \leq 200\text{MHz}$, $Q_x \div 1$	-250	25	200	ps
		CLK1, nCLK1	PLL_SEL = 2.5V, $f_{REF} = 133\text{MHz}$, $Q_x \div 1$	-50	100	250	ps
			PLL_SEL = 2.5V, $f_{REF} = 200\text{MHz}$, $Q_x \div 1$	-100	+100	300	ps
$t_{sk(o)}$	Output Skew; NOTE 3, 4	CLK0	PLL_SEL = 0V			65	ps
		CLK1, nCLK1	PLL_SEL = 0V			55	ps
$t_{jit(cc)}$	Cycle-to-Cycle Jitter; NOTE 4	$f_{OUT} > 40\text{MHz}$			45	ps	
$t_{jit(q)}$	Phase Jitter; NOTE 4, 5	PLL_SEL = 2.5V, $f_{REF} = 66\text{MHz}$, $Q_x * 2$			± 50	ps	
t_L	PLL Lock Time				1	mS	
t_R	Output Rise Time		400		950	ps	
t_F	Output Fall Time		400		950	ps	
odc	Output Duty Cycle		43		57	%	

All parameters measured at f_{MAX} unless noted otherwise.

NOTE 1: Measured from the differential input crossing point to the output at $V_{DDO}/2$.

NOTE 2: Defined as the time difference between the input reference clock and the average feedback input signal when the PLL is locked and the input reference frequency is stable.

NOTE 3: Defined as skew between outputs at the same supply voltages and with equal load conditions.

Measured at $V_{DDO}/2$.

NOTE 4: This parameter is defined in accordance with JEDEC Standard 65.

NOTE 5: Phase jitter is dependent on the input source used.

PARAMETER MEASUREMENT INFORMATION

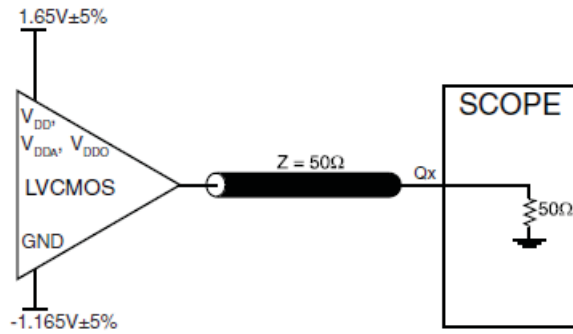

3.3V OUTPUT LOAD AC TEST CIRCUIT

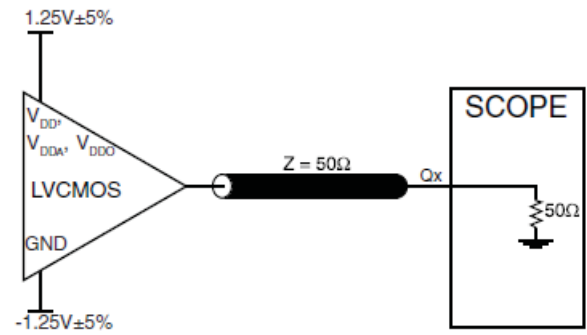

2.5V OUTPUT LOAD AC TEST CIRCUIT

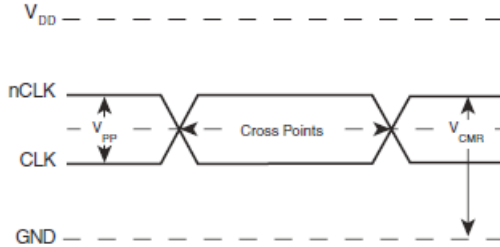

DIFFERENTIAL INPUT LEVEL

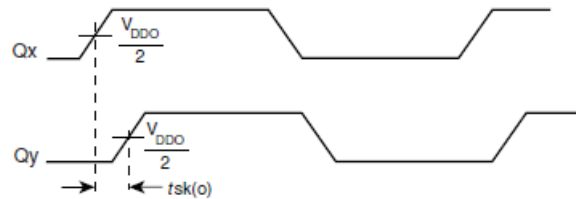

OUTPUT SKEW

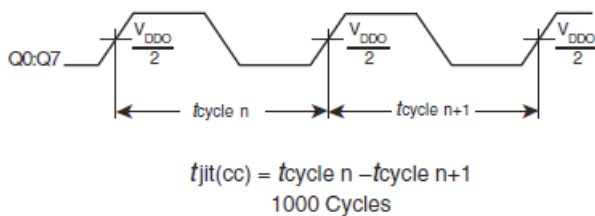

CYCLE-TO-CYCLE JITTER



OUTPUT RISE/FALL TIME

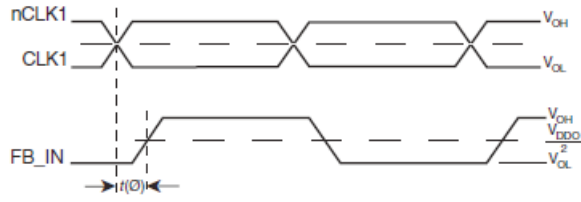

$$f_{jit}(O) = |t(O) - t(O)_{mean}| = \text{Phase Jitter}$$

$$t(O)_{mean} = \text{Static Phase Offset}$$

(where $t(O)$ is any random sample, and $t(O)_{mean}$ is the average of the sampled cycles measured on controlled edges)

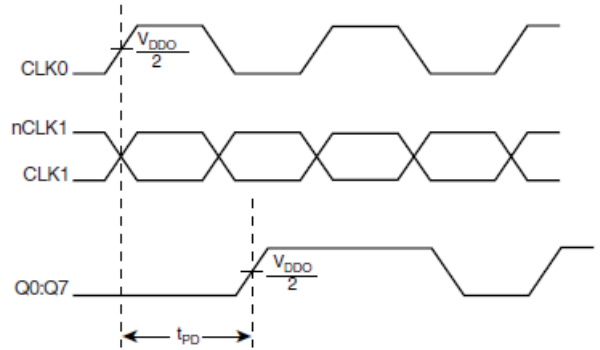

PHASE JITTER & STATIC PHASE OFFSET

PROPAGATION DELAY

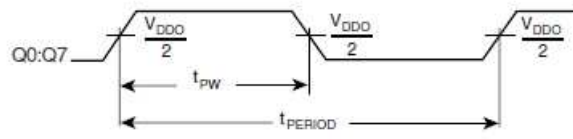

$$odc = \frac{t_{PW}}{t_{PERIOD}}$$

t_{PW} , odc AND t_{PERIOD}

APPLICATION INFORMATION

POWER SUPPLY FILTERING TECHNIQUES

As in any high speed analog circuitry, the power supply pins are vulnerable to random noise. The 8705I provides separate power supplies to isolate any high switching noise from the outputs to the internal PLL. V_{DD} , V_{DDA} , and V_{DDO} should be individually connected to the power supply plane through vias, and bypass capacitors should be used for each pin. To achieve optimum jitter performance, power supply isolation is required. *Figure 1* illustrates how a 10Ω resistor along with a $10\mu\text{F}$ and a $.01\mu\text{F}$ bypass capacitor should be connected to each V_{DDA} .

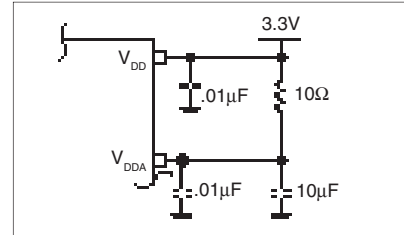

FIGURE 1. POWER SUPPLY FILTERING

WIRING THE DIFFERENTIAL INPUT TO ACCEPT SINGLE ENDED LEVELS

Figure 2 shows how the differential input can be wired to accept single ended levels. The reference voltage $V_{REF} = V_{CC}/2$ is generated by the bias resistors R1, R2 and C1. This bias circuit should be located as close as possible to the input pin. The ratio

of R1 and R2 might need to be adjusted to position the V_{REF} in the center of the input voltage swing. For example, if the input clock swing is only 2.5V and $V_{CC} = 3.3\text{V}$, V_{REF} should be 1.25V and $R2/R1 = 0.609$.

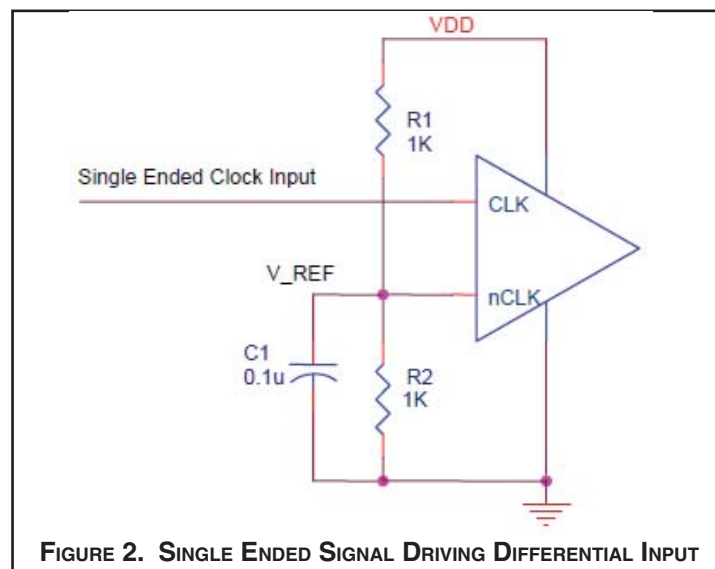

FIGURE 2. SINGLE ENDED SIGNAL DRIVING DIFFERENTIAL INPUT

DIFFERENTIAL CLOCK INPUT INTERFACE

The CLK /nCLK accepts LVDS, LVPECL, LVHSTL, SSTL, HCSSL and other differential signals. Both V_{SWING} and V_{OH} must meet the V_{PP} and V_{CMR} input requirements. Figures 3A to 3D show interface examples for the CLK/nCLK input driven by the most common driver types. The input interfaces suggested here are

examples only. Please consult with the vendor of the driver component to confirm the driver termination requirements. For example in *Figure 4A*, the input termination applies for LVHSTL drivers. If you are using an LVHSTL driver from another vendor, use their termination recommendation.

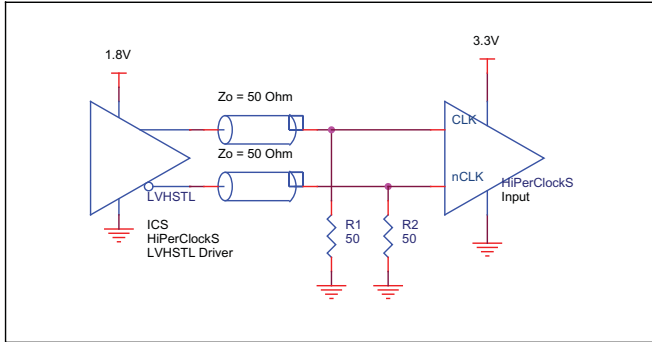

FIGURE 3A. CLK/nCLK INPUT DRIVEN BY LVHSTL DRIVER

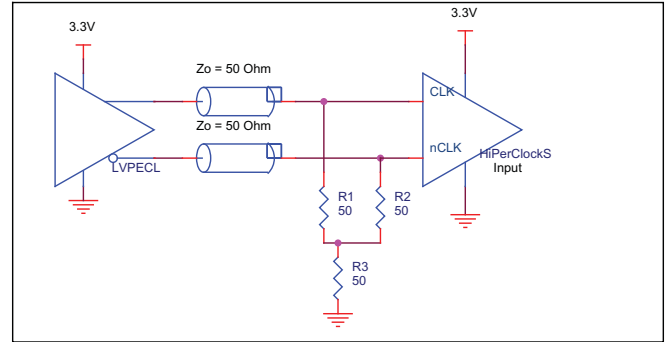

FIGURE 3B. CLK/nCLK INPUT DRIVEN BY 3.3V LVPECL DRIVER

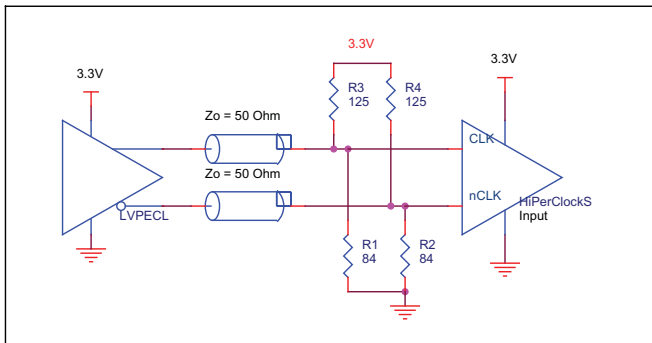

FIGURE 3C. CLK/nCLK INPUT DRIVEN BY 3.3V LVPECL DRIVER

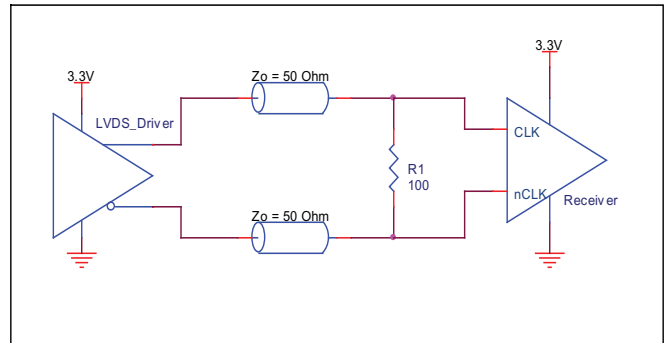

FIGURE 3D. CLK/nCLK INPUT DRIVEN BY 3.3V LVDS DRIVER

LAYOUT GUIDELINE

The schematic of the 8705I layout example is shown in *Figure 4A*. The 8705I recommended PCB board layout for this example is shown in *Figure 4B*. This layout example is used as a general guideline. The layout in the actual system will

depend on the selected component types, the density of the components, the density of the traces, and the stack up of the P.C. board.

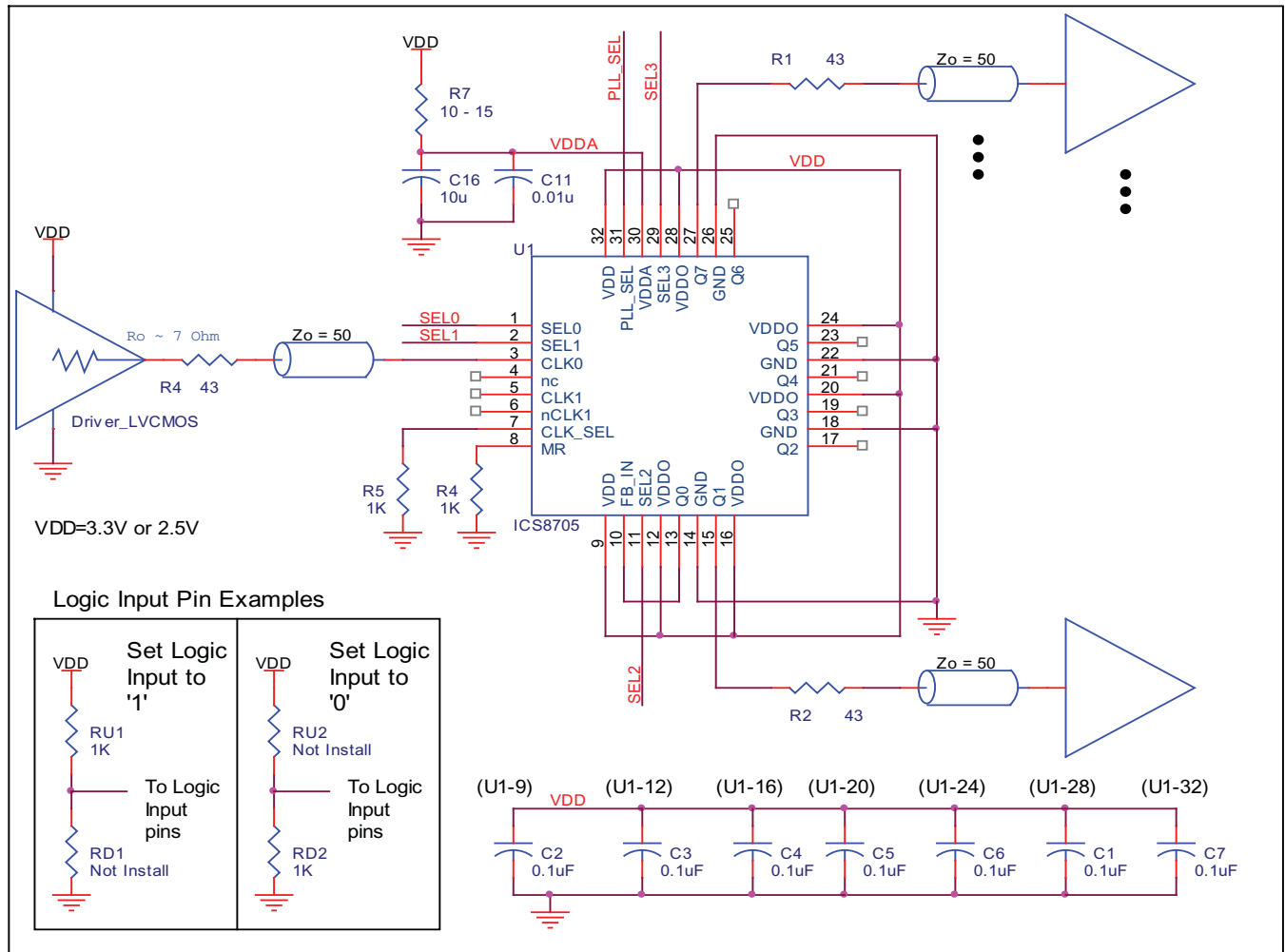

FIGURE 4A. 8705I LVC MOS CLOCK GENERATOR SCHEMATIC EXAMPLE

The following component footprints are used in this layout example:

All the resistors and capacitors are size 0603.

POWER AND GROUNDING

Place the decoupling capacitors as close as possible to the power pins. If space allows, placement of the decoupling capacitor on the component side is preferred. This can reduce unwanted inductance between the decoupling capacitor and the power pin caused by the via.

Maximize the power and ground pad sizes and number of vias capacitors. This can reduce the inductance between the power and ground planes and the component power and ground pins.

The RC filter consisting of R7, C11, and C16 should be placed as close to the V_{DDA} pin as possible.

CLOCK TRACES AND TERMINATION

Poor signal integrity can degrade the system performance or cause system failure. In synchronous high-speed digital systems, the clock signal is less tolerant to poor signal integrity than other signals. Any ringing on the rising or falling edge or excessive ring back can cause system failure. The shape of the

trace and the trace delay might be restricted by the available space on the board and the component location. While routing the traces, the clock signal traces should be routed first and should be locked prior to routing other signal traces.

- The differential 50Ω output traces should have same length.
- Avoid sharp angles on the clock trace. Sharp angle turns cause the characteristic impedance to change on the transmission lines.
- Keep the clock traces on the same layer. Whenever possible, avoid placing vias on the clock traces. Placement of vias on the traces can affect the trace characteristic impedance and hence degrade signal integrity.
- To prevent cross talk, avoid routing other signal traces in parallel with the clock traces. If running parallel traces is unavoidable, allow a separation of at least three trace widths between the differential clock trace and the other signal trace.
- Make sure no other signal traces are routed between the clock trace pair.
- The series termination resistors should be located as close to the driver pins as possible.

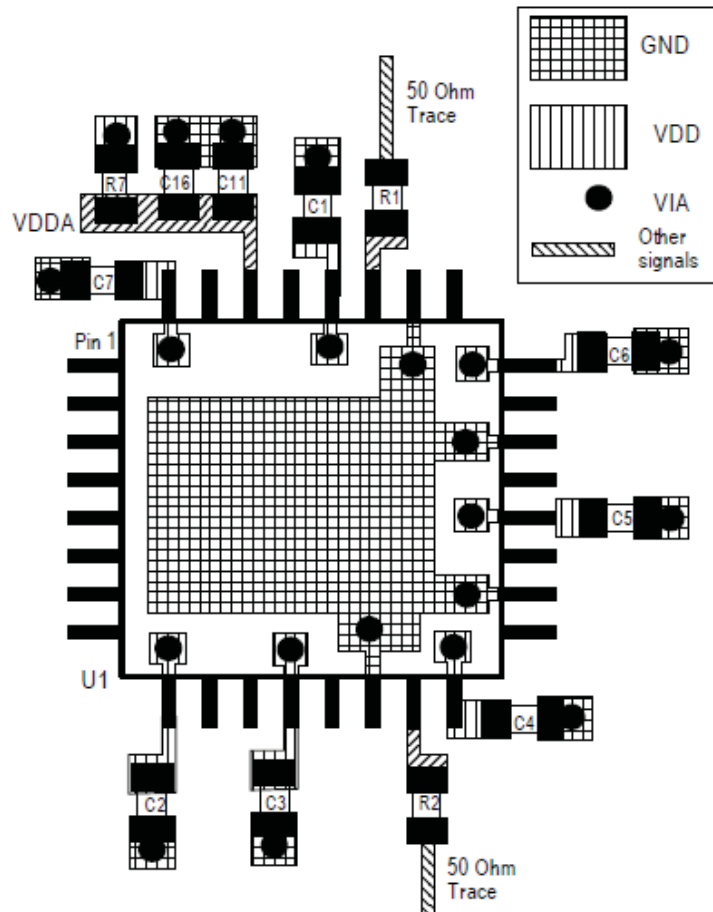

FIGURE 4B. PCB BOARD LAYOUT FOR 8705I

RELIABILITY INFORMATION

TABLE 6. θ_{JA} vs. AIR FLOW TABLE FOR 32 LEAD LQFP

θ_{JA} by Velocity (Linear Feet per Minute)			
	0	200	500
Single-Layer PCB, JEDEC Standard Test Boards	67.8°C/W	55.9°C/W	50.1°C/W
Multi-Layer PCB, JEDEC Standard Test Boards	47.9°C/W	42.1°C/W	39.4°C/W

NOTE: Most modern PCB designs use multi-layered boards. The data in the second row pertains to most designs.

TRANSISTOR COUNT

The transistor count for 8705I is: 3126

PACKAGE OUTLINE - Y SUFFIX FOR 32 LEAD LQFP

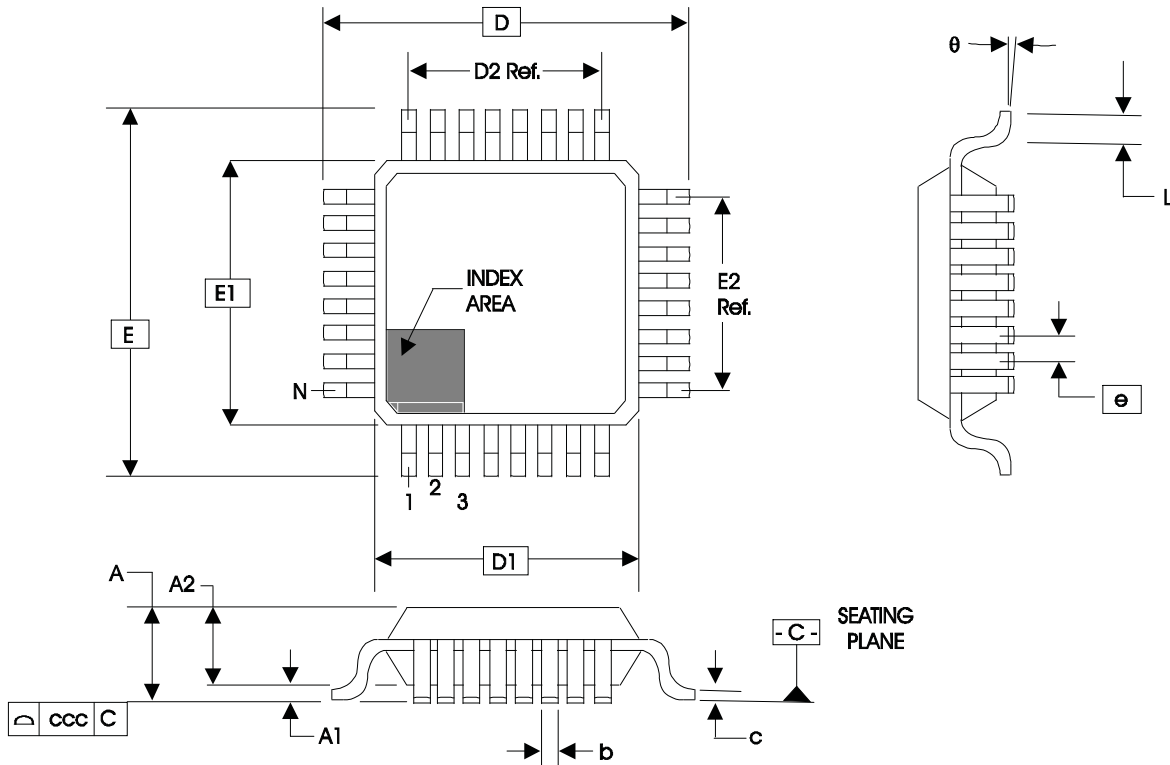

TABLE 7. PACKAGE DIMENSIONS

JEDEC VARIATION ALL DIMENSIONS IN MILLIMETERS			
SYMBOL	BBA		
	MINIMUM	NOMINAL	MAXIMUM
N	32		
A	--	--	1.60
A1	0.05	--	0.15
A2	1.35	1.40	1.45
b	0.30	0.37	0.45
c	0.09	--	0.20
D	9.00 BASIC		
D1	7.00 BASIC		
D2	5.60 Ref.		
E	9.00 BASIC		
E1	7.00 BASIC		
E2	5.60 Ref.		
e	0.80 BASIC		
L	0.45	0.60	0.75
θ	0°	--	7°
ccc	--	--	0.10

Reference Document: JEDEC Publication 95, MS-026

TABLE 8. ORDERING INFORMATION

Part/Order Number	Marking	Package	Shipping Packaging	Temperature
8705BYILF	ICS8705BYILF	32 Lead "Lead Free" LQFP	tray	-40°C to 85°C
8705BYILFT	ICS8705BYILF	32 Lead "Lead Free" LQFP	tape & reel	-40°C to 85°C

NOTE: Parts that are ordered with an "LF" suffix to the part number are the Pb-Free configuration and are RoHS compliant.

REVISION HISTORY SHEET				
Rev	Table	Page	Description of Change	Date
B	3A	3	PLL Enable Function Table - revised the Reference Frequency Range column	4/5/02
	5A	5	3.3V AC Characteristics Table - updated the Output Frequency row from 275MHz Max. to 250MHz Max.	
	5B	7	2.5V AC Characteristics Table - updated the Output Frequency row from 275MHz Max. to 250MHz Max.	
B	1	2	Pin Description Table - revised power pin descriptions.	4/10/02
B	2	2	Pin Characteristics Table - added 23pF to C _{PD} row.	7/15/02
B	1	2	Pin Description Table - Pin# 10 from description, replaced "Connect to pin 10." with "Connect to one of the outputs."	8/1/02
B	1	2	Revised CLK0 description and MR description.	8/21/02
		8	Revised Output Rise/Fall Time Diagram.	
C	1	2	Pin Description table - revised MR and V _{DD} descriptions.	1/22/03
	4A & 4D	4 & 6	Power Supply Table - changed V _{DD} parameter to correspond with the pin description.	
	5A & 5B	5 & 7	AC tables - Changed the Static Phase Offset limits for CLK1, nCLK1.	
D	T5B	7	2.5V AC Characteristics Table - added Phase Jitter spec, and Note 5.	3/14/03
		9	Replaced Static Phase Offset Diagram with Phase Jitter & SPO Diagram.	
D	T2	2	Pin Characteristics Table - changed C _{IN} 4pF max. to 4pF typical. R _{OUT} , added 5W min. and 12W max.	7/14/03
		11	Added Differential Clock Input Interface section.	
		12 & 13	Added Layout Guideline and PCB Board Layout.	
D	T8	1	Added Lead-Free bullet to Features section.	7/8/04
		16	Added Lead-Free part number to Ordering Information table.	
E	T8	16	Updated datasheet's header/footer with IDT from ICS.	7/16/10
		18	Removed "ICS" prefix from Part/Order Number column. Corrected packaging column	
			Added Contact Page.	
E		1	NRND - Nor Recommended For New Designs	5/30/13
E	T8	16	Ordering Information - removed leaded devices. Updated data sheet format	7/13/15

**Corporate Headquarters**

6024 Silver Creek Valley Road
San Jose, California 95138

Sales

800-345-7015 or +408-284-8200
Fax: 408-284-2775
www.IDT.com

Technical Support

email: clocks@idt.com

DISCLAIMER Integrated Device Technology, Inc. (IDT) and its subsidiaries reserve the right to modify the products and/or specifications described herein at any time and at IDT's sole discretion. All information in this document, including descriptions of product features and performance, is subject to change without notice. Performance specifications and the operating parameters of the described products are determined in the independent state and are not guaranteed to perform the same way when installed in customer products. The information contained herein is provided without representation or warranty of any kind, whether express or implied, including, but not limited to, the suitability of IDT's products for any particular purpose, an implied warranty of merchantability, or non-infringement of the intellectual property rights of others. This document is presented only as a guide and does not convey any license under intellectual property rights of IDT or any third parties.

IDT's products are not intended for use in applications involving extreme environmental conditions or in life support systems or similar devices where the failure or malfunction of an IDT product can be reasonably expected to significantly affect the health or safety of users. Anyone using an IDT product in such a manner does so at their own risk, absent an express, written agreement by IDT.

Integrated Device Technology, IDT and the IDT logo are registered trademarks of IDT. Other trademarks and service marks used herein, including protected names, logos and designs, are the property of IDT or their respective third party owners.

Copyright 2015. All rights reserved.