



Chipsmall Limited consists of a professional team with an average of over 10 year of expertise in the distribution of electronic components. Based in Hongkong, we have already established firm and mutual-benefit business relationships with customers from,Europe,America and south Asia,supplying obsolete and hard-to-find components to meet their specific needs.

With the principle of “Quality Parts,Customers Priority,Honest Operation,and Considerate Service”,our business mainly focus on the distribution of electronic components. Line cards we deal with include Microchip,ALPS,ROHM,Xilinx,Pulse,ON,Everlight and Freescale. Main products comprise IC,Modules,Potentiometer,IC Socket,Relay,Connector.Our parts cover such applications as commercial,industrial, and automotives areas.

We are looking forward to setting up business relationship with you and hope to provide you with the best service and solution. Let us make a better world for our industry!



Contact us

Tel: +86-755-8981 8866 Fax: +86-755-8427 6832

Email & Skype: info@chipsmall.com Web: www.chipsmall.com

Address: A1208, Overseas Decoration Building, #122 Zhenhua RD., Futian, Shenzhen, China



24 x 48 Totalizers CTR24 non-backlit model Part number 87622070



- Display : 8-digit LCD, height 8 mm
- Powered by a lithium battery
- Counter inputs : solid state (4-30 VDC) or voltage (10 →260 VAC)
- Reset on panel or external with inhibition option
- Backlit model (2341-2351-2342)
- Counting directions can be selected with input (2241-2341/2251-2351)
- Accessories for 50 x 25 mm cut-out

Part numbers

	Type	Type	Functions
87622070	CTR24 non-backlit model	2242	Voltage input, lithium battery

Specifications

Physical details and protection

Consumption	Backlighting : 24 VDC± 20 % 50 mA
Connection by 8 screw terminals at rear of casing	•
Connection capacity	1,5 mm ²
Fixed using bracket	•
Degree of protection front face	IP 65
Temperature limits use (°C)	-10 →+60
Temperature limits stored (°C)	-20 →+70
Breakdown voltage	EN 61010-1 : 2000 V / 50 Hz / 1 min
Conformity to standards	EN 61000-6-2 - EN 55011 class B
Altitude	2000 m
Certifications	UL - cULus (pending) - CE
Weight (g)	50

Operating characteristics

Function	Impulse counter
Display	8-digit LCD
Height digits (mm)	8
Counting capacity	-9,999,999 →99,999,999 with elimination of zeros

Input 2241-2341

1 slow counting input for contact closure on NPN open-collector transistor input (terminals 2-6)	•
1 input for high speed counting signal from voltage level (terminals 1-6)	4 →30 VDC
Low level	0 →0,7 VDC
High level	4 →30 VDC PNP
High-speed counting	12 K Hz max. 42 µs PNP
Input impedance	100 KΩ PNP

Input 2251-2351

1 slow counting input for contact closure on NPN open-collector transistor input (terminals 2-6)	•
1 input for high speed counting signal from voltage level (terminals 1-6)	3 →30 VDC
Low level	0 →0,7 VDC
High level	3 →30 VDC
High-speed counting	7 K Hz max. 70 µs NPN
Input impedance	1 MΩ

Reset to zero - External 2241-2341 & 2251-2351

Volt-free contact or open collector (terminals 3-6)	•
---	---

Input 2242-2342

1 input for slow counting 2 voltage levels	•
Voltage - Terminals 1-2	10 →260 VAC/DC
Input impedance (kΩ)	160
Slow counting	30 Hz
Minimum pulse time	16 ms
Low level	0 →2 VAC/DC
High level	10 →260 VAC/DC

Reset to zero - External 2242-2342

Voltage - Terminals 2-3	•
Minimum pulse time	16 ms

Low level	0 →2 VAC/DC
High level	10 →260 VAC/DC

Reset to zero - Panel

Reset via	Inhibited : Terminals 4-6 not connected Active : Terminals 4-6 connected
-----------	---

Supply

1 lithium battery - Life (years)	8
----------------------------------	---

Accessories

Description	Code
Adaptor for 50 x 25 mm cut-out - Fixed with screws	26546843
Adaptor for 50 x 25 mm cut-out - Fixed with clips	26546844
DIN rail adaptor	26546840
Clip-fixing kit (supplied with the product)	26546848

Dimensions (mm)

CTR24

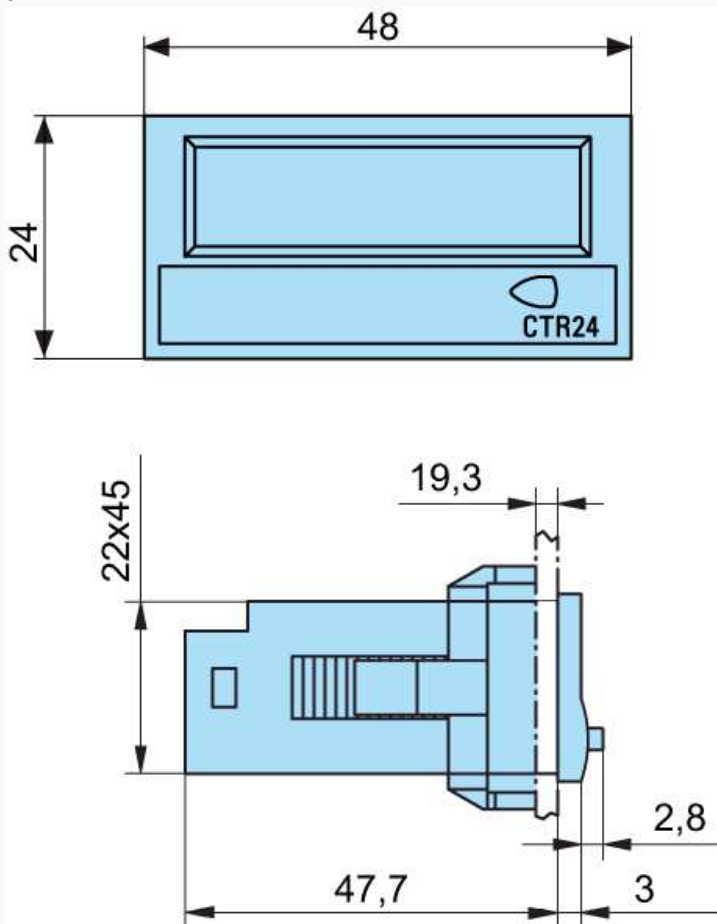
**Dimensions (mm)**

Fixing strip with clip-on yoke

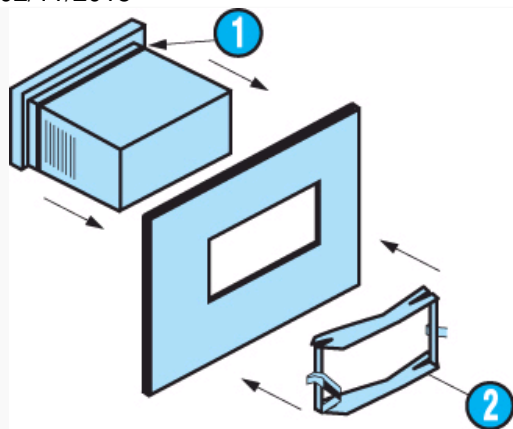

N°	Legend
1	Seal
2	Fixing yoke

Dimensions (mm)

Panel cut-out

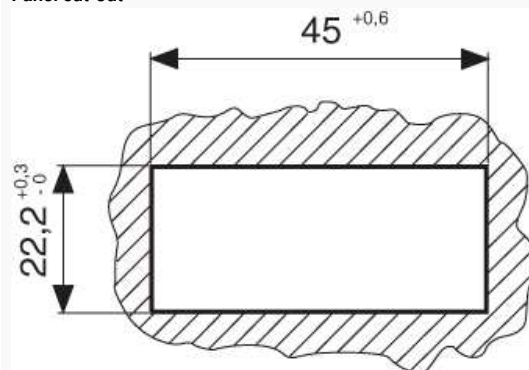

Dimensions (mm)

4 appliances

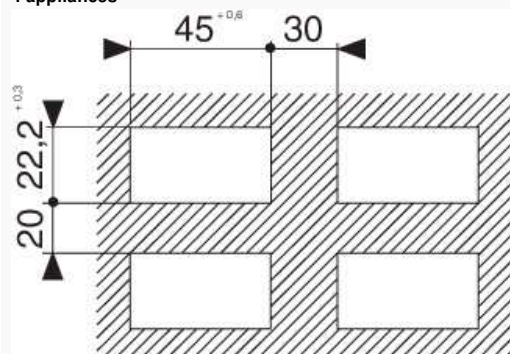

Dimensions (mm)

26546843 - Adaptor for 50 x 25 mm cut-out - Fixed with screws

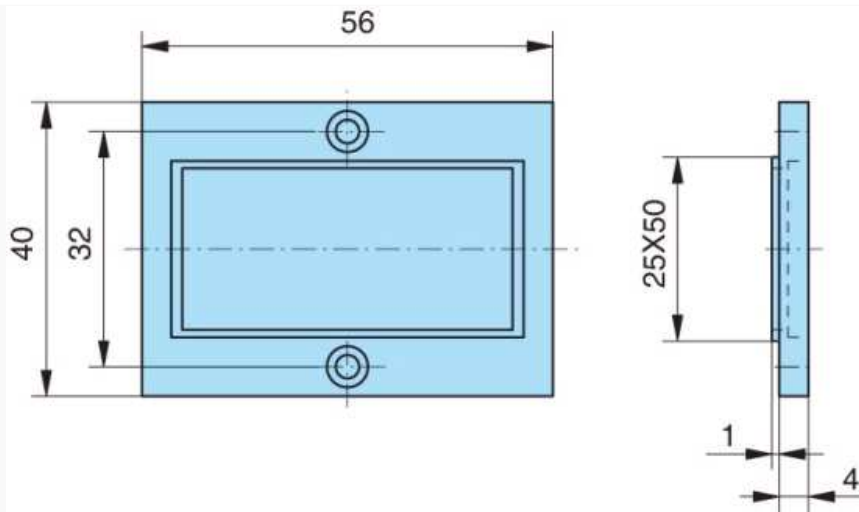
**Dimensions (mm)**

26546844 - Adaptor for 50 x 25 mm cut-out - Fixed with clips

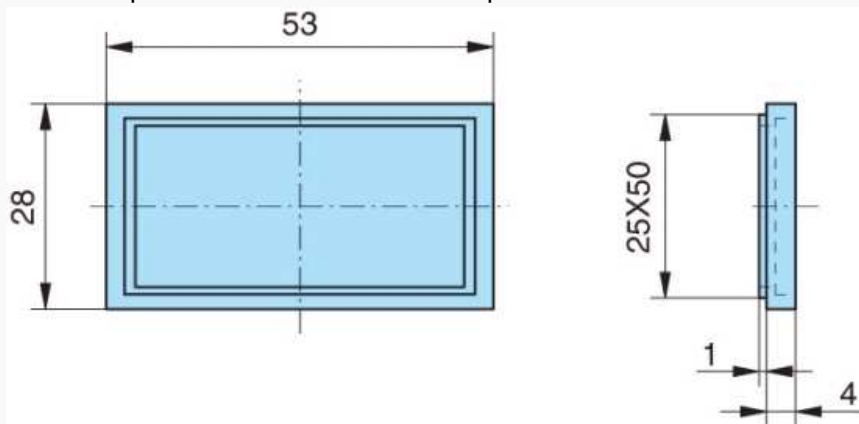

Accessory supplied with the counter

Dimensions (mm)

26546840 - DIN rail adaptor

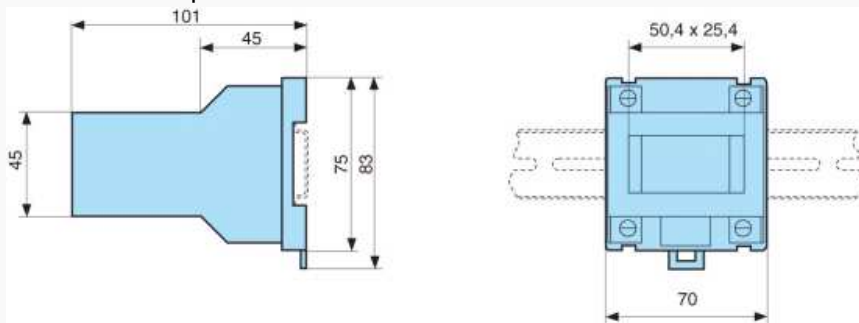

Accessory supplied with the counter

Connections

2241-2341

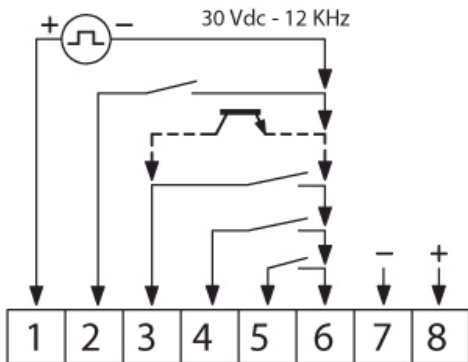
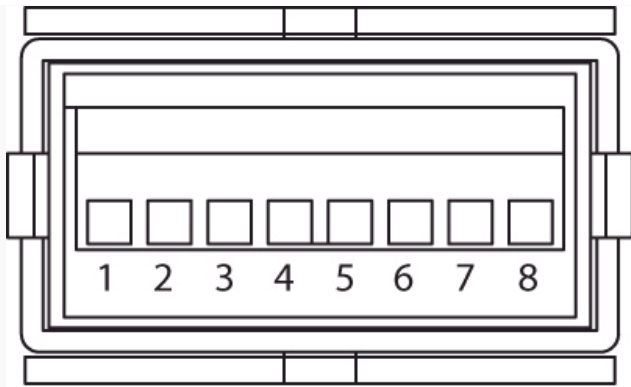

N°	Legend
1	Fast count
2	Slow count
3	Reset input 12 ms
4	Enable panel reset
5	Mode 1 count direction
6	0 V common/ (BL- only 23xx)
7	Backlighting option (only 2341)
8	Backlighting option + 24 VDC (only 2341)

Connections

2241-2341

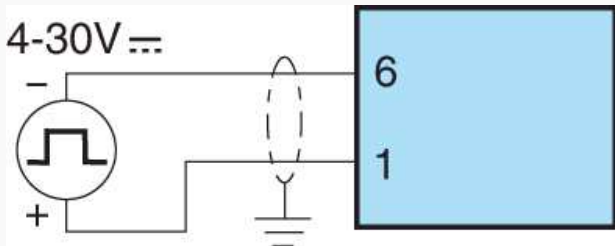

PNP fast count input - Voltage

Connections

2241-2341

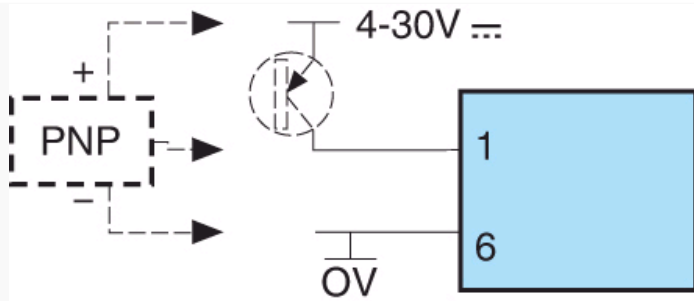

PNP fast count input Transistor or 3-wire PNP proximity sensor (for leakage current detector ≤ 1 mA)

Connections

2241-2341

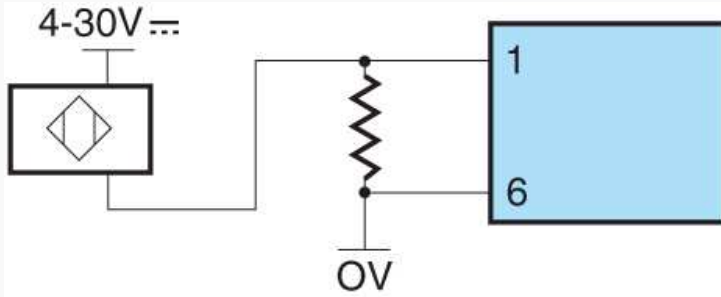

2-wire proximity sensor fast count input

Connections

2241-2341

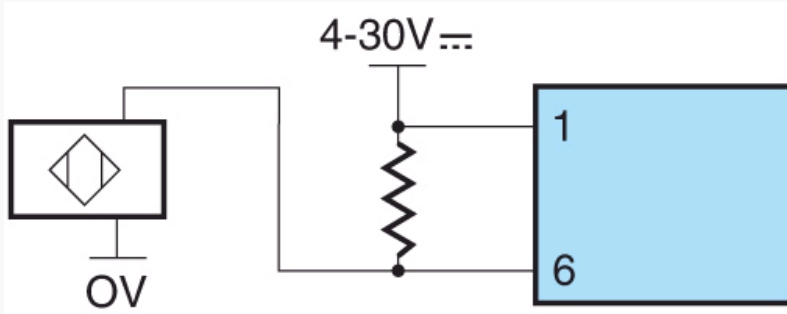

2-wire proximity sensor fast count input

Connections

2241-2341

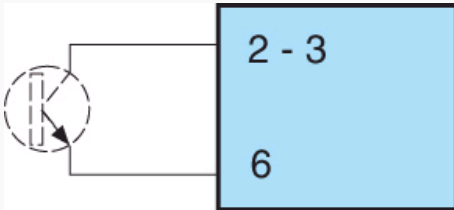

Slow count input (2) or reset input (3)

Connections

2241-2341

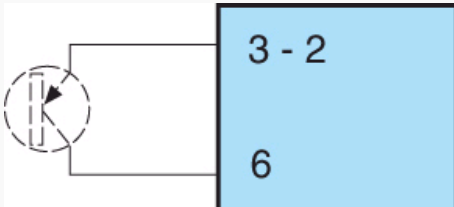

Slow count input (2) or reset input (3) - Contact not supplied with power

Connections

2241-2341

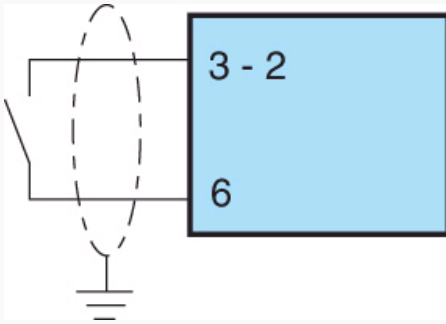

Slow count input (2) or reset input (3) - Contact not supplied with power

Connections

2251-2351

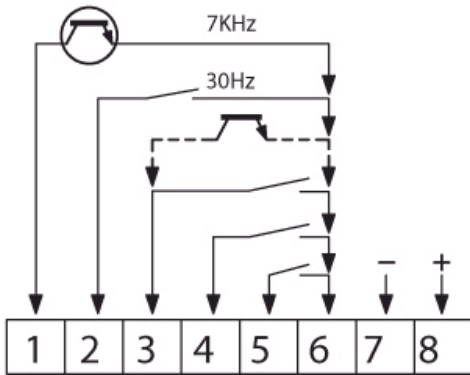
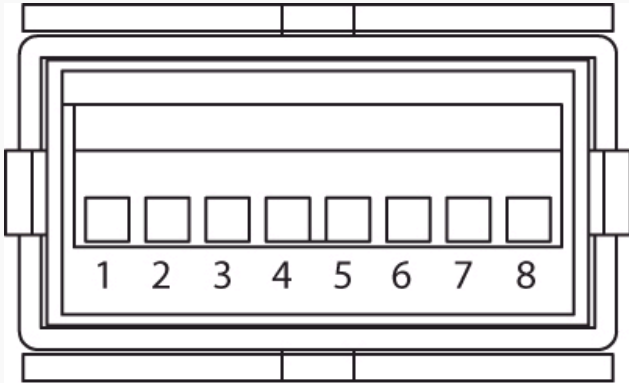

Slow count input (2) or reset input (3) - Contact not supplied with power

N°	Legend
1	Fast count
2	Slow count
3	Reset input 12 ms
4	Enable panel reset
5	Mode 1 count direction
6	0 V common/ (BL- only 23xx)
7	Backlighting option - (only 2351)
8	Backlighting option + 24 VDC (only 2351)

Connections

2251-2351

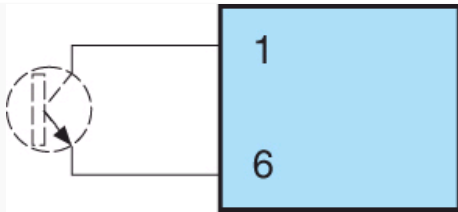

Fast count input NPN - Voltage

Connections

2251-2351

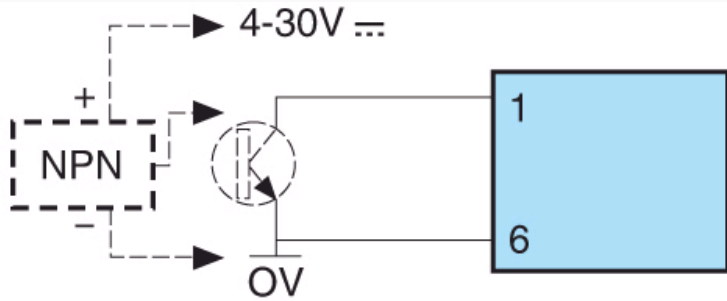

Fast count input NPN Transistor or 3-wire PNP proximity sensor (for leakage current detector ≤ 1 mA)

Connections

2251-2351

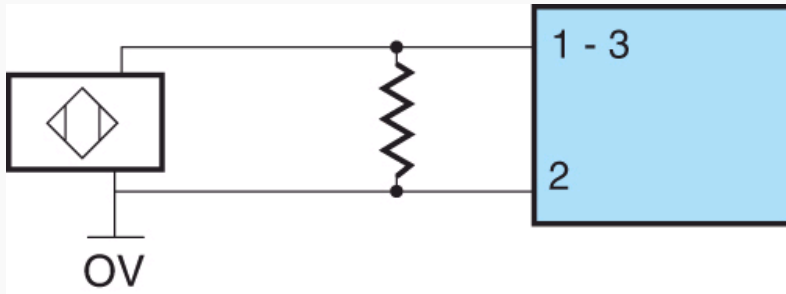

2-wire proximity sensor fast count input

Connections

2251-2351

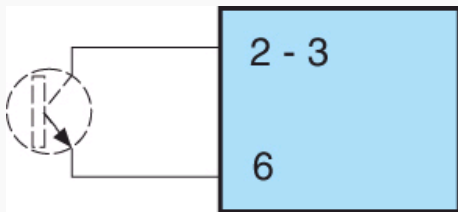

Slow count input (2) or reset input (3)

Connections

2251-2351

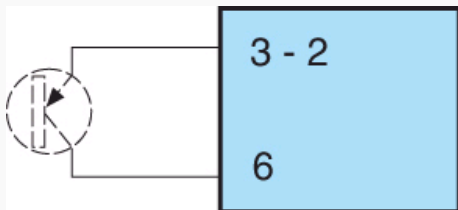

Slow count input (2) or reset input (3)

Connections

2251-2351

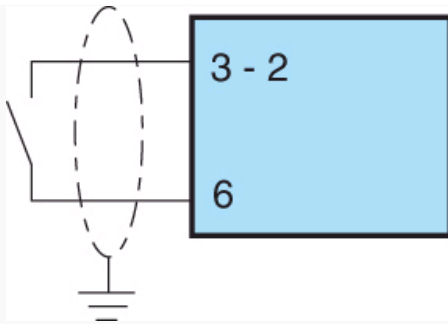

Slow count input (2) or reset input (3) - Contact not supplied with power

Connections

2242-2342

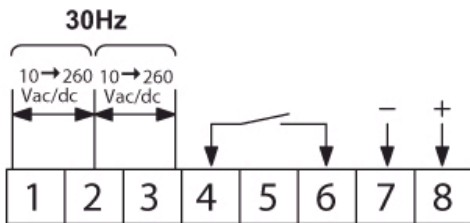
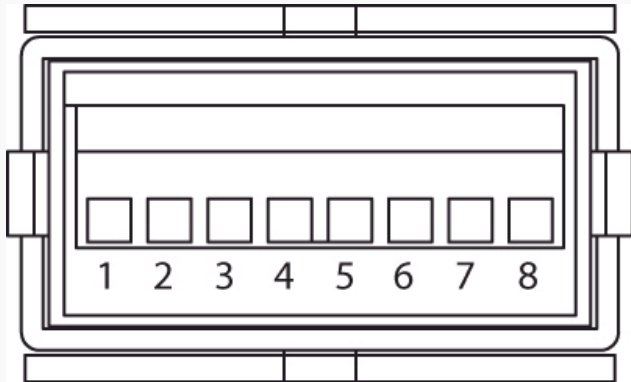

Slow count input (2) or reset input (3) - Contact not supplied with power

N°	Legend
1	Fast count
2	AC/DC common
3	Reset input 12 ms
4	Enable panel reset
5	NC
6	0 V common/ (BL- only 23xx)
7	Backlighting option - (only 2342)
8	Backlighting option + 24 VDC (only 2342)

Connections

2242-2342

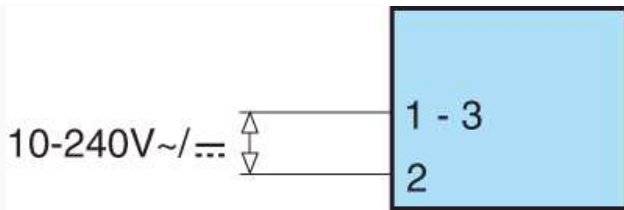

Counter or reset input - Voltage

Connections

2242-2342

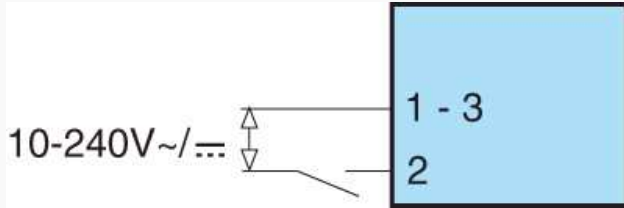

Counter or reset input - Contact supplied with power

Connections

2242-2342

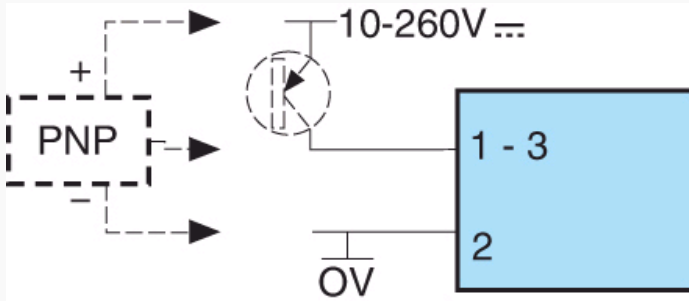

Counter or reset input PNP Transistor or 3-wire PNP proximity sensor (for leakage current detector < 1 mA)

Connections

2242-2342

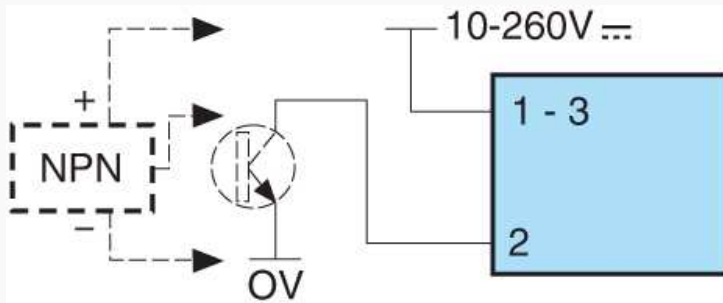

Counter or reset input NPN Transistor or 3-wire PNP proximity sensor (for leakage current detector < 1 mA)

Connections

2242-2342

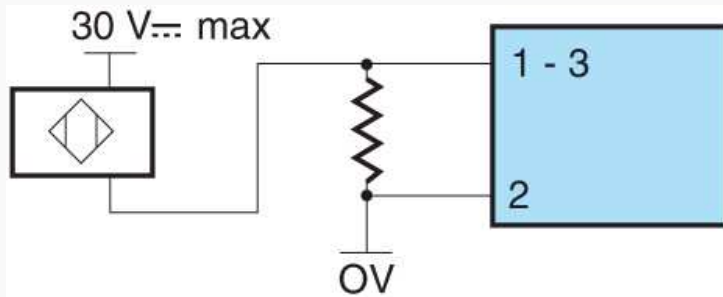

02/11/2015

www.crouzet.com

Start/Stop or reset input : 2-wire proximity sensor R=470 Ω /2 W for 2-wire leakage current detector ≤ 1 mA