



Chipsmall Limited consists of a professional team with an average of over 10 year of expertise in the distribution of electronic components. Based in Hongkong, we have already established firm and mutual-benefit business relationships with customers from,Europe,America and south Asia,supplying obsolete and hard-to-find components to meet their specific needs.

With the principle of “Quality Parts,Customers Priority,Honest Operation,and Considerate Service”,our business mainly focus on the distribution of electronic components. Line cards we deal with include Microchip,ALPS,ROHM,Xilinx,Pulse,ON,Everlight and Freescale. Main products comprise IC,Modules,Potentiometer,IC Socket,Relay,Connector.Our parts cover such applications as commercial,industrial, and automotives areas.

We are looking forward to setting up business relationship with you and hope to provide you with the best service and solution. Let us make a better world for our industry!



Contact us

Tel: +86-755-8981 8866 Fax: +86-755-8427 6832

Email & Skype: info@chipsmall.com Web: www.chipsmall.com

Address: A1208, Overseas Decoration Building, #122 Zhenhua RD., Futian, Shenzhen, China



CUSHIONED CABLE CLAMPS



- Ideal for securing in rugged applications
- These cushioned cable clamps secure tightly and protect against shock and vibration

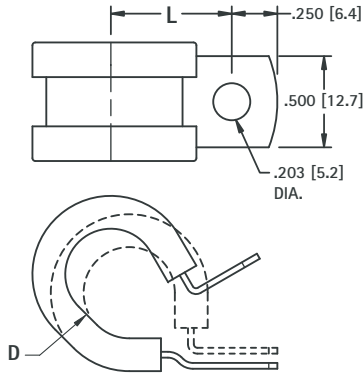

MATERIAL: .032 (0.81) Stainless Steel
Cushion: EPDM Rubber

CAT. NO.	D FOR DIA.	L CTR TO CTR
8090	.250 (6.4)	.711 (18.1)
8091	.375 (9.5)	.500 (12.7)
8092	.500 (12.7)	.562 (14.3)
8093	.625 (15.9)	.718 (18.2)
8094	.750 (19.1)	.781 (19.8)
8095	.875 (22.2)	.843 (21.4)
8096	1.000 (25.4)	.906 (23.0)

CABLE TIE ROUTING CLIP

These clips snap into PC Boards or Panel chassis and are ideal for securing cable wiring, piping, tubing, components and fibre optics when used with cable ties.

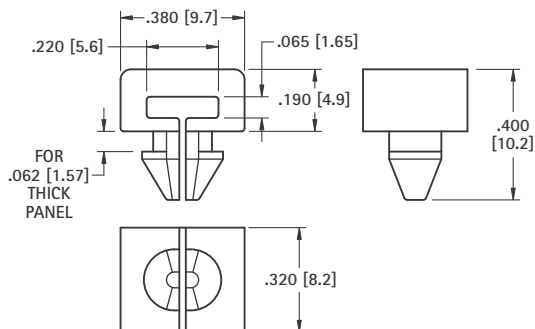

Recommended Mtg. Hole .187 (4.8) diameter.

MATERIAL: Nylon 6/6, UL Rated 94V-2

CAT. NO. 8860

NYLON CABLE CLAMPS

Ideal for securing, insulating and routing cable wiring, piping, tubing, components and fibre optics.

MATERIAL: .050 (1.27) Nylon 6/6, White

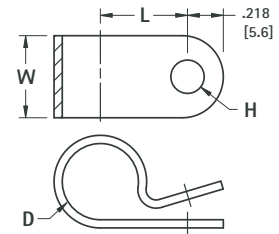

CAT. NO.	D FOR DIA.	L CTR TO CTR	W WIDTH	H HOLE
7620	.125 (3.2)	.325 (8.3)	.375 (9.5)	.140 (3.6)
7621	.125 (3.2)	.325 (8.3)	.375 (9.5)	.203 (5.2)
7622	.187 (4.7)	.380 (9.7)	.375 (9.5)	.140 (3.6)
7623	.187 (4.7)	.380 (9.7)	.375 (9.5)	.203 (5.2)
7624	.250 (6.4)	.410 (10.4)	.375 (9.5)	.140 (3.6)
7625	.250 (6.4)	.410 (10.4)	.375 (9.5)	.203 (5.2)
7626	.312 (7.9)	.445 (11.3)	.375 (9.5)	.140 (3.6)
7627	.312 (7.9)	.445 (11.3)	.375 (9.5)	.203 (5.2)
7628	.375 (9.5)	.475 (12.1)	.375 (9.5)	.140 (3.6)
7629	.375 (9.5)	.475 (12.1)	.375 (9.5)	.203 (5.2)
7630	.437 (11.1)	.525 (13.3)	.375 (9.5)	.140 (3.6)
7631	.437 (11.1)	.525 (13.3)	.375 (9.5)	.203 (5.2)
7632	.500 (12.7)	.550 (14.0)	.375 (9.5)	.140 (3.6)
7633	.500 (12.7)	.550 (14.0)	.375 (9.5)	.203 (5.2)
7634	.562 (14.3)	.625 (15.9)	.500 (12.7)	.203 (5.2)
7635	.625 (15.9)	.660 (16.8)	.500 (12.7)	.203 (5.2)
7636	.750 (19.1)	.785 (19.9)	.500 (12.7)	.203 (5.2)
7637	.875 (22.2)	.845 (21.5)	.500 (12.7)	.203 (5.2)
7638	1.000 (25.4)	.910 (23.1)	.500 (12.7)	.203 (5.2)
7639	1.125 (28.6)	.970 (24.6)	.500 (12.7)	.203 (5.2)
7640	1.250 (31.8)	1.060 (26.9)	.500 (12.7)	.203 (5.2)

NYLON CABLE TIES

Popular sizes and strengths to meet common cable tie requirements. Injection molded with one piece construction for strength and reliability. Easily installed by hand. Optional installation tool available, tightens and flush cuts cable tie.

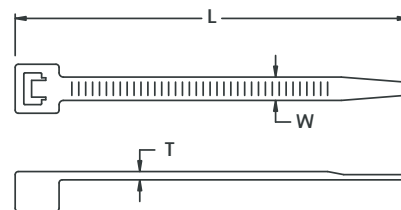

MATERIAL: Natural Nylon 6/6, UL Rated 94V-2

CAT. NO.	TENSILE STRENGTH (Min. Bundle)	FOR BUNDLE DIA. (Max.)	L LENGTH (Approx.)	W WIDTH (Approx.)	T THICKNESS (Approx.)
8865	18 lbs	1.000 (25.4)	4.250 (108.0)	.100 (2.54)	.045 (1.14)
8866	18 lbs	2.000 (50.8)	8.000 (203.2)	.100 (2.54)	.045 (1.14)
8867	40 lbs	1.250 (31.8)	6.000 (152.4)	.140 (3.56)	.050 (1.27)
8868	50 lbs	1.750 (44.5)	7.500 (190.5)	.190 (4.83)	.055 (1.40)
8869	120 lbs	4.000 (101.6)	14.500 (368.3)	.190 (4.83)	.055 (1.40)
8870	Hand Operated Cable Tie Installation Tool for 18lb to 50lb Ties				