



Chipsmall Limited consists of a professional team with an average of over 10 year of expertise in the distribution of electronic components. Based in Hongkong, we have already established firm and mutual-benefit business relationships with customers from,Europe,America and south Asia,supplying obsolete and hard-to-find components to meet their specific needs.

With the principle of “Quality Parts,Customers Priority,Honest Operation,and Considerate Service”,our business mainly focus on the distribution of electronic components. Line cards we deal with include Microchip,ALPS,ROHM,Xilinx,Pulse,ON,Everlight and Freescale. Main products comprise IC,Modules,Potentiometer,IC Socket,Relay,Connector.Our parts cover such applications as commercial,industrial, and automotives areas.

We are looking forward to setting up business relationship with you and hope to provide you with the best service and solution. Let us make a better world for our industry!



Contact us

Tel: +86-755-8981 8866 Fax: +86-755-8427 6832

Email & Skype: info@chipsmall.com Web: www.chipsmall.com

Address: A1208, Overseas Decoration Building, #122 Zhenhua RD., Futian, Shenzhen, China



THIS DRAWING IS UNPUBLISHED. RELEASED FOR PUBLICATION
 © COPYRIGHT - By - ALL RIGHTS RESERVED.

| LOC | | DIST | | REVISIONS | | | |
|-----|-----|-------------|--|---------------------------|---------|-------|--|
| P | LTR | DESCRIPTION | | DATE | DWN | APVD | |
| GP | 00 | P2 | | REVISED PER ECO-12-011709 | 25JUN12 | RW SY | |

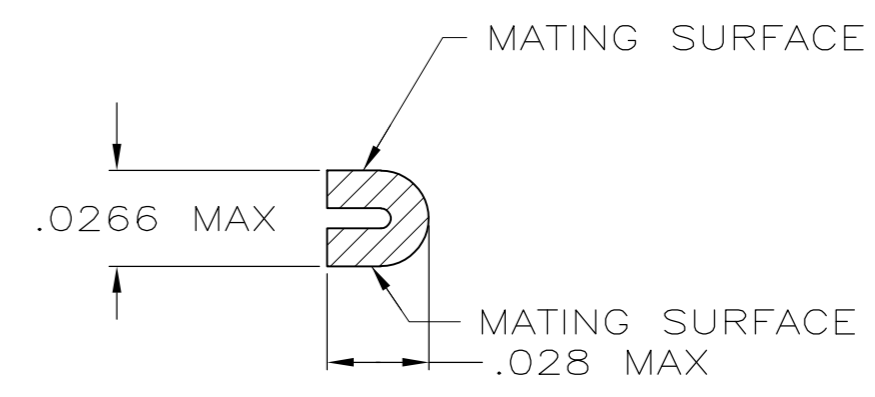
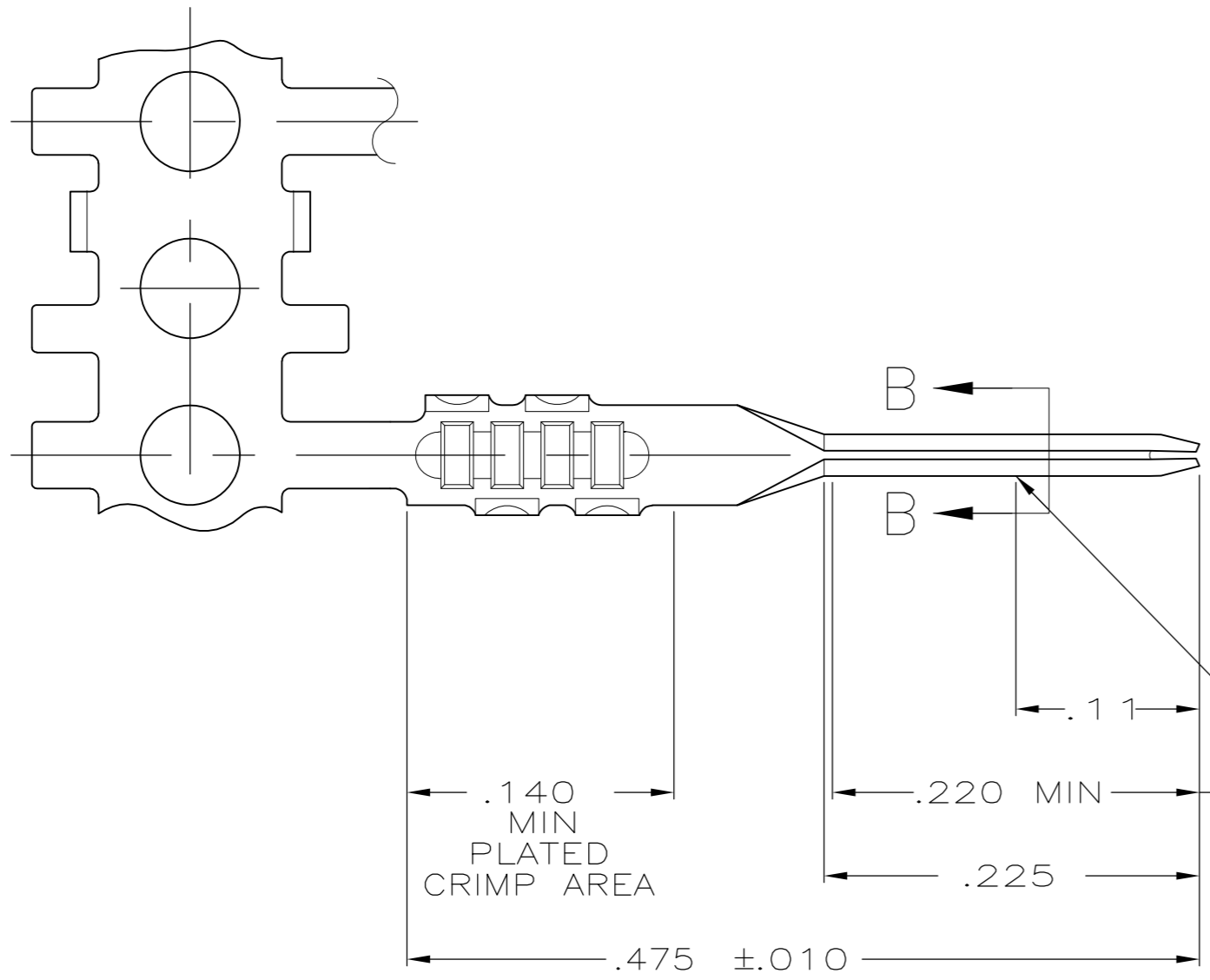

SECTION B-B

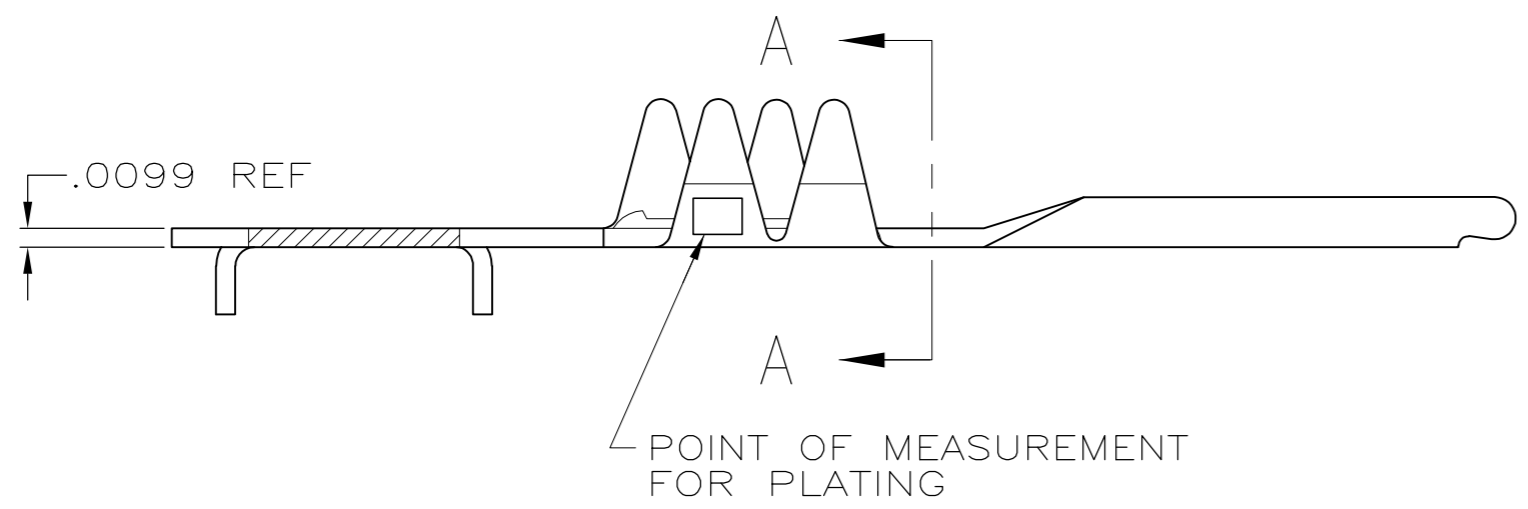

SECTION A-A

- 1 NICKEL UNDERPLATE .000050 MIN THK ON ENTIRE CONTACT WITH GOLD .000015 THK ON LOCALIZED PLATE AREA AND BRIGHT TIN-LEAD .000100 MIN THK IN CRIMP AREA
- 2 BRIGHT TIN-LEAD .000100 MIN THK OVER NICKEL UNDERPLATE .000050 MIN THK ON ENTIRE CONTACT
- 3 GOLD FLASH IN PLATED CRIMP AREA, .00015 MIN GOLD ON LOCALIZED PLATE AREA, BOTH OVER .000050 MIN NICKEL ON ENTIRE CONTACT, -OR- GOLD FLASH OVER PALLADIUM-NICKEL, .000015 MIN TOTAL THK ON LOCALIZED PLATE AREA AND GOLD FLASH ON PLATED CRIMP AREA, BOTH OVER .000050 MIN NICKEL ON ENTIRE CONTACT.
- 4 GOLD FLASH IN PLATED CRIMP AREA, .00100 MIN TIN IN LOCALIZED PLATE AREA, BOTH OVER .000050 MIN NICKEL ON ENTIRE CONTACT.
- 5 GOLD PLATING MAY OR MAY NOT BE PRESENT ON THE BOTTOM OF THE CRIMP BARREL IN THIS AREA.

| | | |
|-----------------------|---|---------|
| 5 | 3 | 88976-5 |
| 5 | 4 | 88976-4 |
| SUPERSEDED BY 88976-5 | | 1 |
| | | 2 |
| FINISH | | PART NO |

| | | | | | | | |
|--|--|------------------|---------------|----------------------------------|---------------------------|------------|--|
| THIS DRAWING IS A CONTROLLED DOCUMENT. | | DWN | P.BERRY | 3-21-86 | TE TE Connectivity | | |
| DIMENSIONS: INCHES | | CHK | D.WORTHINGTON | 3-24-86 | | | |
| TOLERANCES UNLESS OTHERWISE SPECIFIED: | | APVD | R. SMITH | 3-25-86 | NAME | | |
| 0 PLC ± - | | PRODUCT SPEC | | CONTACT, FFC .100CL, .025 SQ PIN | | | |
| 1 PLC ± - | | APPLICATION SPEC | | 108-9024 | | | |
| 2 PLC ± .02 | | MATERIAL | | 114-16015 | | | |
| 3 PLC ± .005 | | FINISH | | SEE TABLE | | | |
| 4 PLC ± - | | MATERIAL | | PHOS BRONZE | | | |
| 5 ANGLES ± - | | WEIGHT | | - | | | |
| FINISH | | CUSTOMER DRAWING | | SCALE NTS | | | |
| SEE TABLE | | SIZE | | CAGE CODE | | DRAWING NO | |
| | | A2 | | 00779 | | 88976 | |
| | | SHEET | | 1 OF 1 | | REV P2 | |