



Chipsmall Limited consists of a professional team with an average of over 10 year of expertise in the distribution of electronic components. Based in Hongkong, we have already established firm and mutual-benefit business relationships with customers from,Europe,America and south Asia,supplying obsolete and hard-to-find components to meet their specific needs.

With the principle of “Quality Parts,Customers Priority,Honest Operation,and Considerate Service”,our business mainly focus on the distribution of electronic components. Line cards we deal with include Microchip,ALPS,ROHM,Xilinx,Pulse,ON,Everlight and Freescale. Main products comprise IC,Modules,Potentiometer,IC Socket,Relay,Connector.Our parts cover such applications as commercial,industrial, and automotives areas.

We are looking forward to setting up business relationship with you and hope to provide you with the best service and solution. Let us make a better world for our industry!



## Contact us

Tel: +86-755-8981 8866 Fax: +86-755-8427 6832

Email & Skype: info@chipsmall.com Web: www.chipsmall.com

Address: A1208, Overseas Decoration Building, #122 Zhenhua RD., Futian, Shenzhen, China



### General Description

The 894D115I-01 is a clock and data recovery circuit. The device is designed to extract the clock signal from a NRZ-coded STM-4 (OC-12/STS-12) or STM-1 (OC-3/STS-3) input data signal. The output signals of the device are the recovered clock and retimed data signals. Input and output are differential signals for best signal integrity and to support high clock and data rates. All control inputs and outputs are single-ended signals. An internal PLL is used for clock generation and recovery. An external clock input is provided to establish an initial operating frequency of the clock recovery PLL and to provide a clock reference in the absence of serial input data. The device supports a signal detect input and a lock detect output. A bypass circuit is provided to facilitate factory tests.

### Features

- Clock recovery for STM-4 (OC-12/STS-12) and STM-1 (OC-3/STS-3)
- Input: NRZ data (622.08 or 155.52 Mbit/s)
- Output: clock signal (622.08MHz or 155.52MHz) and retimed data signal at 622.08 or 155.52 Mbit/s
- Internal PLL for clock generation and clock recovery
- Differential inputs can accept LVPECL levels
- Differential LVPECL data and clock outputs
- Lock reference input and PLL lock output
- 19.44MHz reference clock input
- Full 3.3V supply mode
- -40°C to 85°C operating temperature
- Available in lead-free (RoHS 6) package
- See ICS894D115I for a clock/data recovery circuit with a TSSOP EPAD package
- See ICS894D115I-04 for a clock/data recovery circuit with LVDS outputs

### Block Diagram

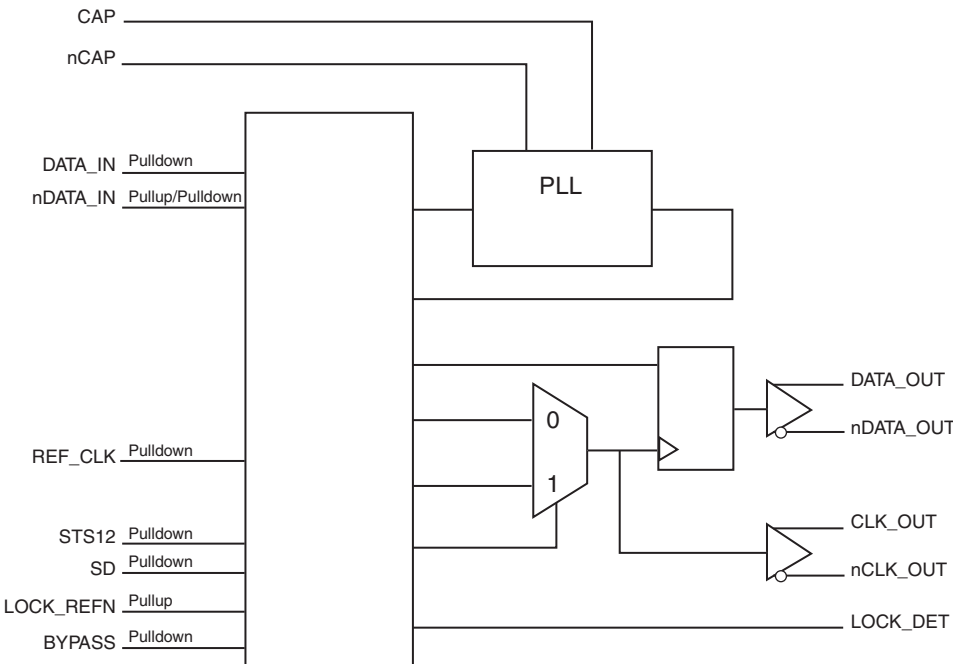

### Pin Assignment

V <sub>CCA</sub>	1	20	V <sub>CCA</sub>
DATA_IN	2	19	V <sub>EE_PLL</sub>
nDATA_IN	3	18	CAP
V <sub>EE_PLL</sub>	4	17	nCAP
LOCK_DET	5	16	BYPASS
STS12	6	15	SD
REF_CLK	7	14	DATA_OUT
LOCK_REFN	8	13	nDATA_OUT
V <sub>EE</sub>	9	12	CLK_OUT
V <sub>CC</sub>	10	11	nCLK_OUT

### 894D115I-01

20-Lead TSSOP

6.5mm x 4.4mm x 0.925mm

package body

G Package

Top View

## Functional Description

The 894D115I-01 is designed to extract the clock from a NRZ-coded STM-4 (OC-12/STS-12) or STM-1 (OC-3/STS-3) input data signal. The output signals are the recovered clock and retimed data signal. The device contains an integrated PLL for clock generation and to lock the output clock to the input data stream. The PLL attempts to lock to the reference clock input (REF\_CLK) in absence of the serial data stream or if it is forced to by the control inputs LOCK\_REFN or SD. The output clock frequency is controlled by the STS12 input. The output frequency is 622.08MHz in STM-4/OC-12/STS-12 mode and 155.52MHz in STM-1/OC-3/STS-3 mode.

The 894D115I-01 will maintain an output (CLK\_OUT/ nCLK\_OUT) frequency deviation of less than  $\pm 500$ ppm with respect to the REF\_CLK reference frequency in a loss of signal state (LOS). During the LOS state, DATA\_OUT is held at logic LOW state and nDATA\_OUT is held at logic HIGH state. An LOS state of the 894D115I-01 is given when BYPASS is set to the logic LOW state and either one of the SD or LOCK\_REFN inputs are at a logic LOW state. This will enable the use of the SD (signal detect) and the

LOCK\_REFN (lock-to-reference) inputs to accept loss of signal status information from electro-optical receivers. Please refer to *Figure 1, "Signal Detect/PLL Bypass Operation Control Diagram"*, for details.

The lock detect output (LOCK\_DET) can be used to monitor the operating state of the clock/data recovery circuit. LOCK\_DET is set to logic LOW level when the internal oscillator of the PLL and the reference clock (REF\_CLK) deviate from each other by more than 500ppm, or when the CDR is forced to lock the REF\_CLK input by the LOCK\_REFN or SD control input. LOCK\_DET is set to HIGH when the PLL is locked to the input data stream and indicates valid clock and data output signals.

The BYPASS pin should be set to logic LOW state in all applications. BYPASS set to logic HIGH state is used during factory test. In BYPASS mode (BYPASS and STS12 are at logic HIGH state), the internal PLL is bypassed and the inverted REF\_CLK input signal is output at CLK\_OUT/nCLK\_OUT.

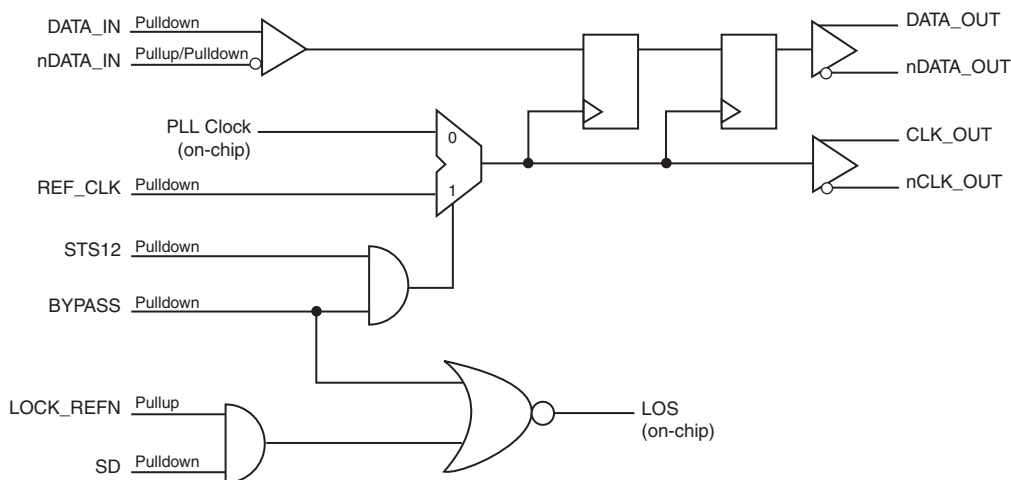

**Figure 1. Signal Detect/PLL Bypass Operation Control Diagram**



**Table 1. Signal Detect/PLL BYPASS Operation Control Table**

Inputs				Outputs	
STS12	BYPASS	LOCK_REFN	SD	DATA_OUT	CLK_OUT
1	0	1	1	DATA_IN	PLL Clock
1	0	1	0	LOW	PLL Clock
1	0	0	1	LOW	PLL Clock
1	0	0	0	LOW	PLL Clock
1	1	X	X	DATA_IN	REF_CLK
0	0	1	1	DATA_IN	PLL Clock
0	0	1	0	LOW	PLL Clock
0	0	0	1	LOW	PLL Clock
0	0	0	0	LOW	PLL Clock
0	1	X	X	Not Allowed	Not Allowed

**Table 2. Pin Descriptions**

Number	Name	Type		Description
1, 20	V <sub>CCA</sub>	Power		Analog supply pins.
2	DATA_IN	Input	Pulldown	Non-inverting differential signal input.
3	nDATA_IN	Input	Pullup/ Pulldown	Inverting differential signal input. V <sub>CC</sub> /2 default when left floating.
4, 19	V <sub>EE_PLL</sub>	Power		Negative supply pins.
5	LOCK_DT	Output		Lock detect output. See Table 4A. Single-ended LVPECL interface levels.
6	STS12	Input	Pulldown	STM-4 (OC-12, STS-12) or STM-1 (OC-3, STS-3) selection mode. See Table 4B. LVCMOS/LVTTL interface levels.
7	REF_CLK	Input	Pulldown	Reference clock input of 19.44MHz. LVCMOS/LVTTL interface levels.
8	LOCK_REFN	Input	Pullup	Lock to REF_CLK input. See Table 4C. LVCMOS/LVTTL interface levels.
9	V <sub>EE</sub>	Power		Negative supply pin.
10	V <sub>CC</sub>	Power		Core supply pin.
11, 12	nCLK_OUT, CLK_OUT	Output		Differential clock output pair. LVPECL interface levels.
13, 14	nDATA_OUT, DATA_OUT	Output		Differential clock output pair. LVPECL interface levels.
15	SD	Input	Pulldown	Signal detect input. Typically, SD is driven by the signal detect output of the electro-optical module. See Table 4D. Single-ended LVPECL interface levels.
16	BYPASS	Input	Pulldown	PLL bypass mode. See Table 4E. LVCMOS/LVTTL interface levels.
17, 18	nCAP, CAP	Input		External loop filter (1.0μF ±10%).

NOTE: *Pullup and Pulldown* refer to internal input resistors. See Table 3, *Pin Characteristics*, for typical values.

**Table 3. Pin Characteristics**

Symbol	Parameter	Test Conditions	Minimum	Typical	Maximum	Units
C <sub>IN</sub>	Input Capacitance			4		pF
R <sub>PULLUP</sub>	Input Pullup Resistor			51		kΩ
R <sub>PULLDOWN</sub>	Input Pulldown Resistor			51		kΩ

## Function Tables

**Table 4A. LOCK\_DET Operation Table**

Operation	Output
	LOCK_DET
The PLL is not locked to the serial input data stream if any of these three conditions occur: A. Internal oscillator and REF_CLK input frequency are not within 500ppm of each other. B. SD input is at logic LOW state. C. LOCK_REFN is at logic LOW state.	LOW
When the PLL is locked to the serial input data stream, the CLK_OUT and DATA_OUT signals are valid.	HIGH

**Table 4B. STS12 Mode Configuration Table**

Input	Operation
STS12	
0	STM-1 (OC-3, STS-3) operation. The clock/data recovery circuit attempts to recover the clock from a 155.52 Mbit/s input data stream. The output clock frequency is 155.52MHz.
1	STM-4 (OC-12, STS-12) operation. The clock/data recovery circuit attempts to recover the clock from a 622.08 Mbit/s input data stream. The output clock frequency is 622.08MHz.

**Table 4C. LOCK\_REFN Mode Configuration Table**

Input	Operation
LOCK_REFN	
0	Lock to reference clock. CLK_OUT/nCLK_OUT output frequency is within ±500ppm of the reference clock (REF_CLK). DATA_OUT is set to logic LOW state and nDATA_OUT is set to logic HIGH state. (DATA_OUT = L, nDATA_OUT = H).
1	Normal operation.

**Table 4D. SD Mode Configuration Table**

Input	Operation
SD	
0	Indicates a loss-of-signal (LOS) condition to the device. CLK_OUT/nCLK_OUT output frequency is within ±500ppm of the reference clock (REF_CLK). DATA_OUT is set to logic LOW state and nDATA_OUT is set to logic HIGH state. (DATA_OUT = L, nDATA_OUT = H).
1	Normal operation.

**Table 4E. BYPASS Mode Configuration Table**

Input	Operation
BYPASS	
0	Normal operation.
1	PLL bypassed (for factory test). The inverted REF_CLK input signal is output at CLK_OUT/nCLK_OUT.

## Absolute Maximum Ratings

NOTE: Stresses beyond those listed under *Absolute Maximum Ratings* may cause permanent damage to the device. These ratings are stress specifications only. Functional operation of product at these conditions or any conditions beyond those listed in the *DC Characteristics* or *AC Characteristics* is not implied. Exposure to absolute maximum rating conditions for extended periods may affect product reliability.

Item	Rating
Supply Voltage, $V_{CC}$	4.6V
Inputs, $V_I$	-0.5V to $V_{CC} + 0.5V$
Outputs, $I_O$ Continuous Current Surge Current	50mA 100mA
Package Thermal Impedance, $\theta_{JA}$	81.3°C/W (0 mps)
Storage Temperature, $T_{STG}$	-65°C to 150°C

## DC Electrical Characteristics

**Table 5A. Power Supply DC Characteristics,  $V_{CC} = 3.3V \pm 5\%$ ,  $V_{EE} = 0V$ ,  $T = -40^\circ C$  to  $85^\circ C$** 

Symbol	Parameter	Test Conditions	Minimum	Typical	Maximum	Units
$V_{CC}$	Core Supply Voltage		3.135	3.3	3.465	V
$V_{CCA}$	Analog Supply Voltage		$V_{CC} - 0.10$	3.3	$V_{CC}$	V
$I_{EE}$	Power Supply Current				80	mA
$I_{CCA}$	Analog Supply Current				10	mA

**Table 5B. LVCMOS/LVTTL DC Characteristics,  $V_{CC} = 3.3V \pm 5\%$ ,  $V_{EE} = 0V$ ,  $T = -40^\circ C$  to  $85^\circ C$** 

Symbol	Parameter	Test Conditions	Minimum	Typical	Maximum	Units
$V_{IH}$	Input High Voltage		2		$V_{CC} + 0.3$	V
$V_{IL}$	Input Low Voltage		-0.3		0.8	V
$I_{IH}$	Input High Current	REF_CLK, STS12, BYPASS	$V_{CC} = V_{IN} = 3.465V$		150	$\mu A$
		LOCK_REFN	$V_{CC} = V_{IN} = 3.465V$		10	$\mu A$
$I_{IL}$	Input Low Current	REF_CLK, STS12, BYPASS	$V_{CC} = 3.465V, V_{IN} = 0V$	-10		$\mu A$
		LOCK_REFN	$V_{CC} = 3.465V, V_{IN} = 0V$	-150		$\mu A$

**Table 5C. Differential DC Characteristics,  $V_{CC} = 3.3V \pm 5\%$ ,  $V_{EE} = 0V$ ,  $T = -40^{\circ}C$  to  $85^{\circ}C$** 

Symbol	Parameter	Test Conditions	Minimum	Typical	Maximum	Units
$I_{IH}$	Input High Current	DATA_IN/nDATA_IN $V_{CC} = V_{IN} = 3.465V$			150	$\mu A$
$I_{IL}$	Input Low Current	DATA_IN $V_{CC} = 3.465V, V_{IN} = 0V$	-10			$\mu A$
		nDATA_IN $V_{CC} = 3.465V, V_{IN} = 0V$	-150			$\mu A$
$V_{IH}$	Input High Voltage		$V_{DD} - 1.75$		$V_{DD} - 0.4$	V
$V_{IL}$	Input Low Voltage		$V_{DD} - 2.0$		$V_{DD} - 0.7$	V
$\Delta V_{IN}$	Differential Input Voltage		250			mV

**Table 5D. LVPECL DC Characteristics,  $V_{CC} = 3.3V \pm 5\%$ ,  $V_{EE} = 0V$ ,  $T = -40^{\circ}C$  to  $85^{\circ}C$** 

Symbol	Parameter	Test Conditions	Minimum	Typical	Maximum	Units
$V_{IH}$	Input High Voltage	SD	$V_{CC} - 1.125$			V
$V_{IL}$	Input Low Voltage	SD			$V_{CC} - 1.5$	V
$I_{IH}$	Input High Current	SD $V_{CC} = V_{IN} = 3.465V$			150	$\mu A$
$I_{IL}$	Input Low Current	SD $V_{CC} = 3.465V, V_{IN} = 0V$	-10			$\mu A$
$V_{OH}$	Output High Voltage; NOTE 1		$V_{CC} - 1.4$		$V_{CC} - 0.9$	V
$V_{OL}$	Output Low Voltage; NOTE 1		$V_{CC} - 2.0$		$V_{CC} - 1.7$	V
$V_{SWING}$	Peak-to-Peak Output Voltage Swing		0.6		1.0	V

 NOTE 1: Outputs terminated with  $50\Omega$  to  $V_{CC} - 2V$ .

## AC Electrical Characteristics

**Table 6. AC Characteristics,  $V_{CC} = 3.3V \pm 5\%$ ,  $V_{EE} = 0V$ ,  $T = -40^{\circ}C$  to  $85^{\circ}C$**

Parameter	Symbol		Test Conditions	Minimum	Typical	Maximum	Units
$f_{VCO}$	VCO Center Frequency				622.08		MHz
$f_{TOL}$	CRU's Reference Clock Frequency Tolerance			-250		250	ppm
$f_{T_{REF\_CLK}}$	OC-12/STS-12 Capture Range		With respect to the fixed reference frequency		$\pm 500$		ppm
$t_{LOCK}$	Acquisition Lock Time	OC-12/STS-12	Valid REF_CLK and device already powered-up			16	$\mu s$
$J_{GEN\_CLK}$	Jitter Generation	CLK_OUT/ nCLK_OUT	14ps rms (max.) jitter on DATA_IN/nDATA_IN		0.005	0.01	UI
$J_{TOL}$	Jitter Tolerance	OC-12/STS-12; NOTE 1	Sinusoidal input jitter of DATA_IN/ nDATA_IN from 250kHz to 5MHz	0.45			UI
$t_R / t_F$	Output Rise/Fall Time; NOTE 1		20% to 80%			500	ps
odc	Output Duty Cycle; NOTE 1		20% minimum transition density	45		55	%
$t_S$	Setup Time; NOTE 1		STS-3	2000	3220		ps
			STS-12	450	800		ps
$t_H$	Hold Time; NOTE 1		STS-3	3000	3220		ps
			STS-12	650	800		ps

NOTE 1: See diagram in *Parameter Measurement Information* section.



### Parameter Measurement Information

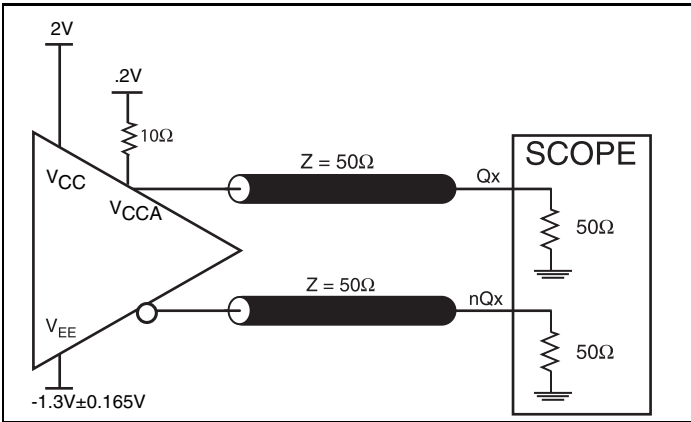

3.3V Output Load AC Test Circuit

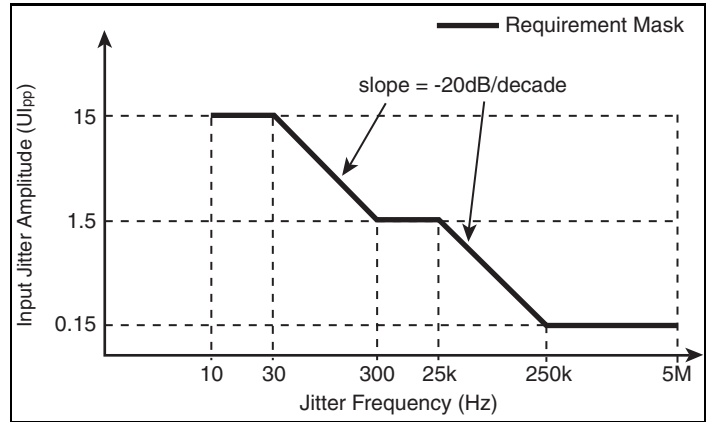

Jitter Tolerance Specification

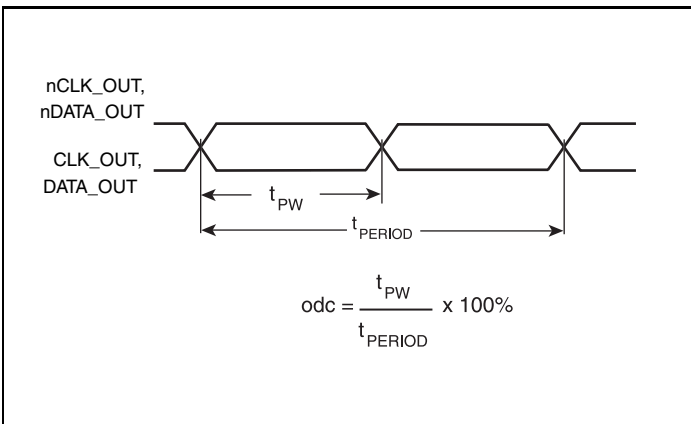

Output Duty Cycle/Pulse Width/Period

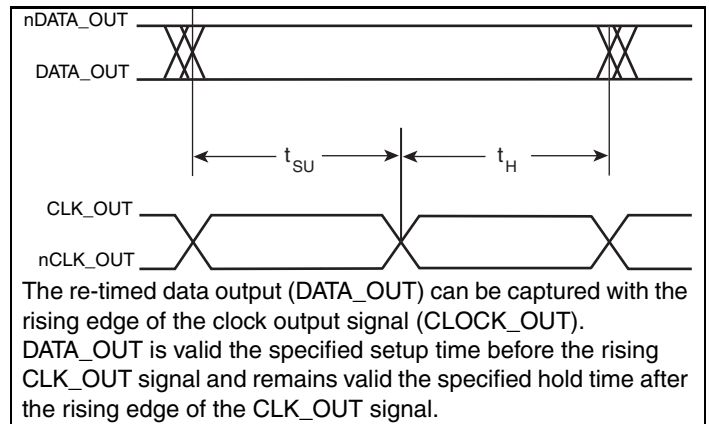

Setup/Hold Time

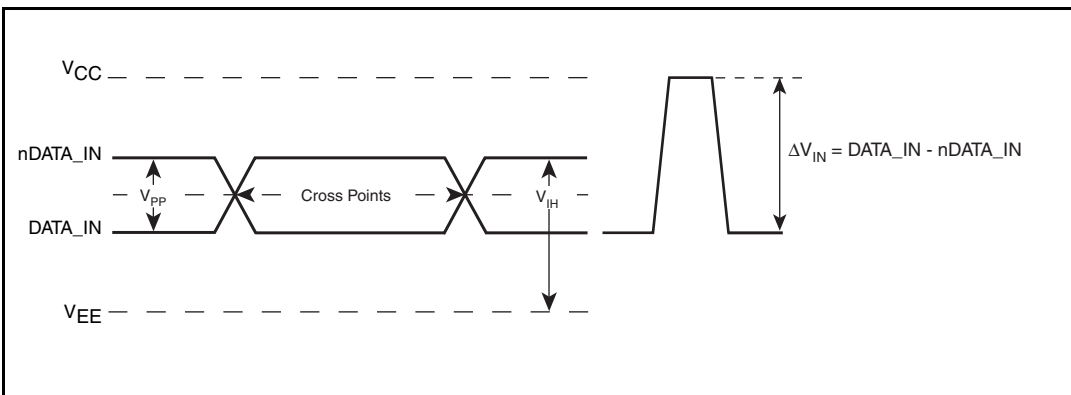

Differential Input Level

## Parameter Measurement Information, continued

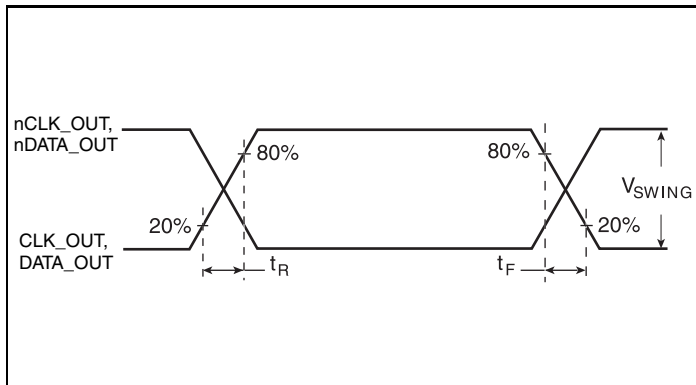

**Output Rise/Fall Time**

## Application Information

### Power Supply Filtering Technique

As in any high speed analog circuitry, the power supply pins are vulnerable to random noise. To achieve optimum jitter performance, power supply isolation is required. The 894D115I-01 provides separate power supplies to isolate any high switching noise from the outputs to the internal PLL.  $V_{CC}$  and  $V_{CCA}$  should be individually connected to the power supply plane through vias, and  $0.01\mu\text{F}$  bypass capacitors should be used for each pin. *Figure 2* illustrates how a  $10\Omega$  resistor along with a  $10\mu\text{F}$  and a  $0.01\mu\text{F}$  bypass capacitor should be connected to each  $V_{CCA}$  pin.

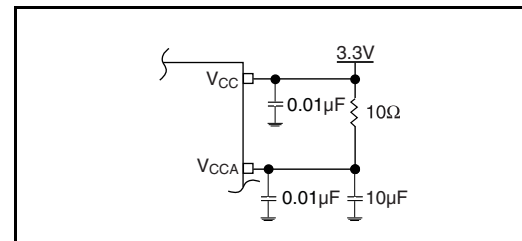

**Figure 2. Power Supply Filtering**

## Recommendations for Unused Input and Output Pins

### Inputs:

#### LVC MOS Control Pins

All control pins have internal pull-ups or pull-downs; additional resistance is not required but can be added for additional protection. A  $1\text{k}\Omega$  resistor can be used.

### Outputs:

#### LVPECL Outputs

All unused LVPECL outputs can be left floating. We recommend that there is no trace attached. Both sides of the differential output pair should either be left floating or terminated.

### Termination for 3.3V LVPECL Outputs

The clock layout topology shown below is a typical termination for LVPECL outputs. The two different layouts mentioned are recommended only as guidelines.

FOUT and nFOUT are low impedance follower outputs that generate ECL/LVPECL compatible outputs. Therefore, terminating resistors (DC current path to ground) or current sources must be used for functionality. These outputs are designed to drive 50Ω transmission

lines. Matched impedance techniques should be used to maximize operating frequency and minimize signal distortion. *Figures 3A and 3B* show two different layouts which are recommended only as guidelines. Other suitable clock layouts may exist and it would be recommended that the board designers simulate to guarantee compatibility across all printed circuit and clock component process variations.

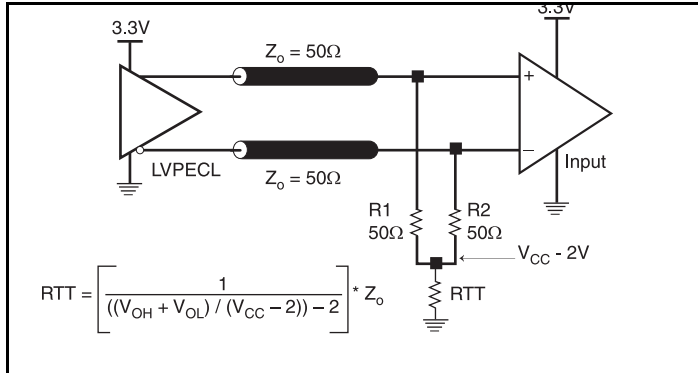

Figure 3A. 3.3V LVPECL Output Termination

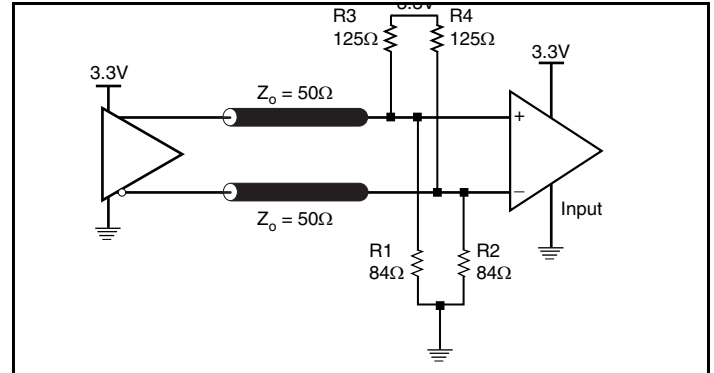

Figure 3B. 3.3V LVPECL Output Termination

## Power Considerations

This section provides information on power dissipation and junction temperature for the 894D115I-01. Equations and example calculations are also provided.

### 1. Power Dissipation.

The total power dissipation for the 894D115I-01 is the sum of the core power plus the power dissipated in the load(s). The following is the power dissipation for  $V_{CC} = 3.3V + 5\% = 3.465V$ , which gives worst case results.

NOTE: Please refer to Section 3 for details on calculating power dissipated in the load.

- Power (core)<sub>MAX</sub> =  $V_{CC\_MAX} * I_{EE\_MAX} = 3.465V * 80mA = 277.20mW$
- Power (outputs)<sub>MAX</sub> = **30mW/Loaded Output pair**  
If all outputs are loaded, the total power is  $2 * 30mW = 60mW$

**Total Power**<sub>MAX</sub> (3.3V, with all outputs switching) =  $277mW + 60mW = 337mW$

### 2. Temperature.

Junction temperature,  $T_j$ , is the temperature at the junction of the bond wire and bond pad and directly affects the reliability of the device. The maximum recommended junction temperature for HiPerClockS devices is 125°C.

Lower temperature refers to ambient temperature, maximum temperature refers to case temperature.

**Table 7. Thermal Resistance  $\theta_{JA}$  for 20 Lead TSSOP, Forced Convection**

Meters per Second	$\theta_{JA}$ by Velocity		
	0	1	2.5
Multi-Layer PCB, JEDEC Standard Test Boards	81.3°C/W	76.9°C/W	74.8°C/W

### 3. Calculations and Equations.

The purpose of this section is to derive the power dissipated into the load.

LVPECL output driver circuit and termination are shown in *Figure 4*.

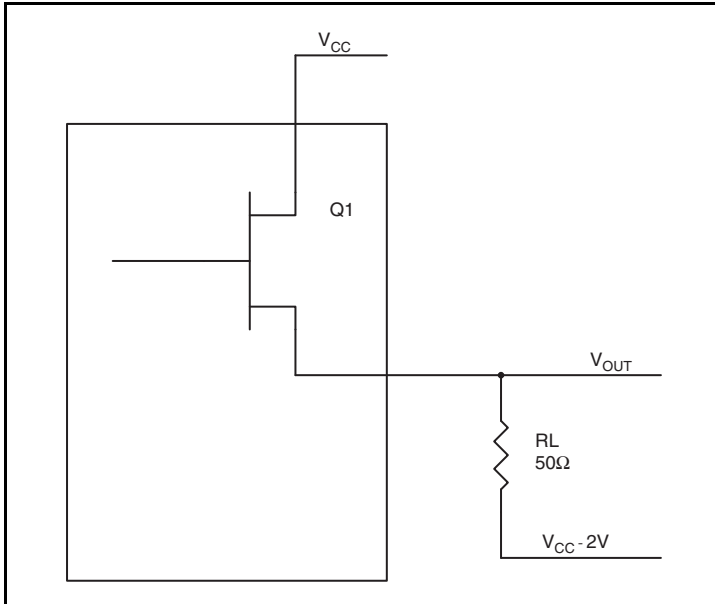

**Figure 4. LVPECL Driver Circuit and Termination**

To calculate worst case power dissipation into the load, use the following equations which assume a 50Ω load, and a termination voltage of  $V_{CC} - 2V$ .

- For logic high,  $V_{OUT} = V_{OH\_MAX} = V_{CC\_MAX} - 0.9V$   
 $(V_{CC\_MAX} - V_{OH\_MAX}) = 0.9V$
- For logic low,  $V_{OUT} = V_{OL\_MAX} = V_{CC\_MAX} - 1.7V$   
 $(V_{CC\_MAX} - V_{OL\_MAX}) = 1.7V$

$Pd_H$  is power dissipation when the output drives high.

$Pd_L$  is the power dissipation when the output drives low.

$$Pd_H = [(V_{OH\_MAX} - (V_{CC\_MAX} - 2V))/R_L] * (V_{CC\_MAX} - V_{OH\_MAX}) = [(2V - (V_{CC\_MAX} - V_{OH\_MAX}))/R_L] * (V_{CC\_MAX} - V_{OH\_MAX}) = [(2V - 0.9V)/50\Omega] * 0.9V = \mathbf{19.8mW}$$

$$Pd_L = [(V_{OL\_MAX} - (V_{CC\_MAX} - 2V))/R_L] * (V_{CC\_MAX} - V_{OL\_MAX}) = [(2V - (V_{CC\_MAX} - V_{OL\_MAX}))/R_L] * (V_{CC\_MAX} - V_{OL\_MAX}) = [(2V - 1.7V)/50\Omega] * 1.7V = \mathbf{10.2mW}$$

$$\text{Total Power Dissipation per output pair} = Pd_H + Pd_L = \mathbf{30mW}$$



## Reliability Information

Table 8.  $\theta_{JA}$  vs. Air Flow Table for a 20 Lead TSSOP

$\theta_{JA}$ by Velocity			
Meters per Second	0	1	2.5
Multi-Layer PCB, JEDEC Standard Test Boards	81.3°C/W	76.9°C/W	74.8°C/W

## Transistor Count

The transistor count for 894D115I-01 is: 10,406

Compatible with VSC8115

## Package Outline and Package Dimensions

Package Outline - G Suffix for 20 Lead TSSOP

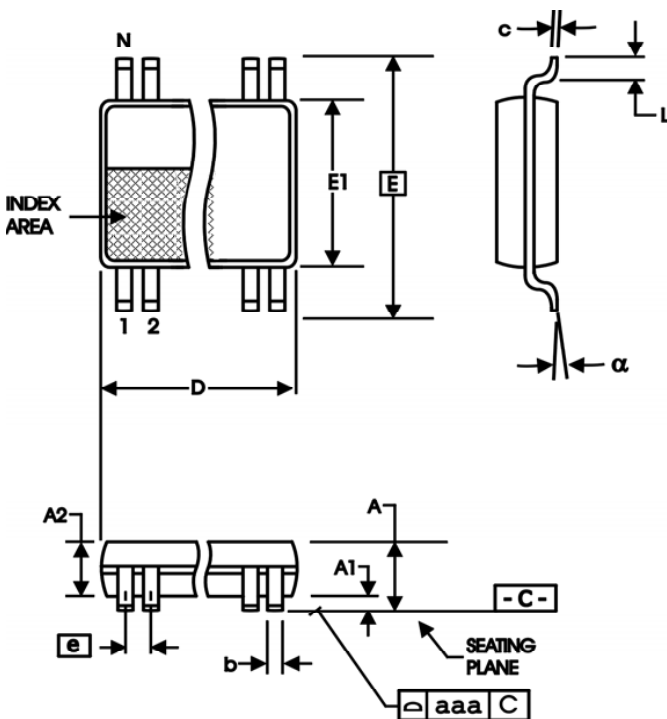

All Dimensions in Millimeters		
Symbol	Minimum	Maximum
E	6.40 Basic	
E1	4.30	4.50
e	0.65 Basic	
L	0.45	0.75
$\alpha$	0°	8°
aaa		0.10

Reference Document: JEDEC Publication 95, MO-153

Table 9. Package Dimensions

All Dimensions in Millimeters		
Symbol	Minimum	Maximum
N	20	
A		1.20
A1	0.05	0.15
A2	0.80	1.05
b	0.19	0.30
c	0.09	0.20
D	6.40	6.60

## Ordering Information

Table 10. Ordering Information

Part/Order Number	Marking	Package	Shipping Packaging	Temperature
894D115BGI-01LF	ICSD115BI01L	"Lead-Free" 20 Lead TSSOP	Tube	-40°C to 85°C
894D115BGI-01LFT	ICSD115BI01L	"Lead-Free" 20 Lead TSSOP	2500 Tape & Reel	-40°C to 85°C

NOTE: Parts that are ordered with an "LF" suffix to the part number are the Pb-Free configuration and are RoHS compliant.

## Revision History Sheet

Rev	Table	Page	Description of Change	Date
B	T6	7	AC Characteristics Table - corrected typo for Hold Time, STS-3 spec. from 300ps to 3000ps max.	6/24/08
C	T5C	6	Differential DC Characteristics Table - deleted $V_{PP}$ and $V_{CMR}$ specs and added $V_{IH}$ , $V_{IL}$ , $\Delta V_{IN}$ specs.	10/15/08
		8	Parameter Measurement Information Section - updated Differential Input Level diagram.	
C	T10	14	Ordering Information - removed leaded devices, PDN CQ-13-02 Updated data sheet format	2/19/15



**Corporate Headquarters**  
6024 Silver Creek Valley Road  
San Jose, CA 95138 USA

**Sales**  
1-800-345-7015 or 408-284-8200  
Fax: 408-284-2775  
www.IDT.com

**Tech Support**  
email: [clocks@idt.com](mailto:clocks@idt.com)

DISCLAIMER Integrated Device Technology, Inc. (IDT) and its subsidiaries reserve the right to modify the products and/or specifications described herein at any time and at IDT's sole discretion. All information in this document, including descriptions of product features and performance, is subject to change without notice. Performance specifications and the operating parameters of the described products are determined in the independent state and are not guaranteed to perform the same way when installed in customer products. The information contained herein is provided without representation or warranty of any kind, whether express or implied, including, but not limited to, the suitability of IDT's products for any particular purpose, an implied warranty of merchantability, or non-infringement of the intellectual property rights of others. This document is presented only as a guide and does not convey any license under intellectual property rights of IDT or any third parties.

IDT's products are not intended for use in applications involving extreme environmental conditions or in life support systems or similar devices where the failure or malfunction of an IDT product can be reasonably expected to significantly affect the health or safety of users. Anyone using an IDT product in such a manner does so at their own risk, absent an express, written agreement by IDT.

While the information presented herein has been checked for both accuracy and reliability, Integrated Device Technology (IDT) assumes no responsibility for either its use or for the infringement of any patents or other rights of third parties, which would result from its use. No other circuits, patents, or licenses are implied. This product is intended for use in normal commercial applications. Any other applications, such as those requiring extended temperature ranges, high reliability or other extraordinary environmental requirements are not recommended without additional processing by IDT. IDT reserves the right to change any circuitry or specifications without notice. IDT does not authorize or warrant any IDT product for use in life support devices or critical medical instruments.

Integrated Device Technology, IDT and the IDT logo are registered trademarks of IDT. Product specification subject to change without notice. Other trademarks and service marks used herein, including protected names, logos and designs, are the property of IDT or their respective third party owners.

Copyright ©2015 Integrated Device Technology, Inc.. All rights reserved.