



Chipsmall Limited consists of a professional team with an average of over 10 year of expertise in the distribution of electronic components. Based in Hongkong, we have already established firm and mutual-benefit business relationships with customers from,Europe,America and south Asia,supplying obsolete and hard-to-find components to meet their specific needs.

With the principle of "Quality Parts,Customers Priority,Honest Operation,and Considerate Service",our business mainly focus on the distribution of electronic components. Line cards we deal with include Microchip,ALPS,ROHM,Xilinx,Pulse,ON,Everlight and Freescale. Main products comprise IC,Modules,Potentiometer,IC Socket,Relay,Connector.Our parts cover such applications as commercial,industrial, and automotives areas.

We are looking forward to setting up business relationship with you and hope to provide you with the best service and solution. Let us make a better world for our industry!



## Contact us

Tel: +86-755-8981 8866 Fax: +86-755-8427 6832

Email & Skype: info@chipsmall.com Web: www.chipsmall.com

Address: A1208, Overseas Decoration Building, #122 Zhenhua RD., Futian, Shenzhen, China



THIS DRAWING IS UNPUBLISHED. RELEASED FOR PUBLICATION  
 © COPYRIGHT BY TYCO ELECTRONICS CORPORATION. ALL RIGHTS RESERVED.

LOC	DIST	REVISIONS					
FT	0	P	LTR	DESCRIPTION	DATE	DWN	APVD
			F	REVISED PER ECO-09-004812	04MAY10	HMR	CR

**MATERIALS:**  
 HOUSING: THERMOPLASTIC, UL94V-0, BLACK.  
 TERMINAL: BRIGHT TIN OVER COPPER ALLOY.  
 SCREWS: 8-32, ZINC PLATED STEEL.







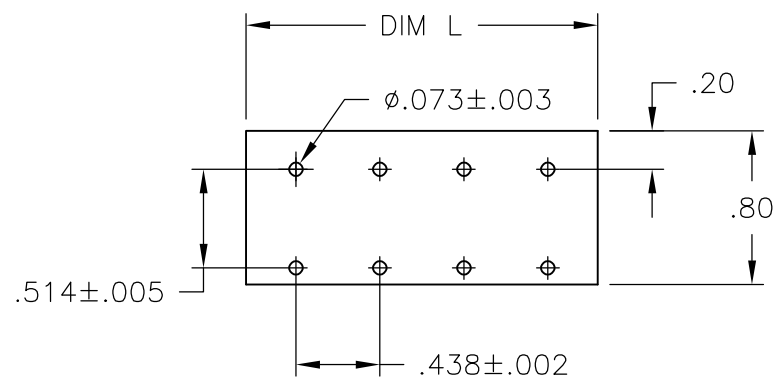
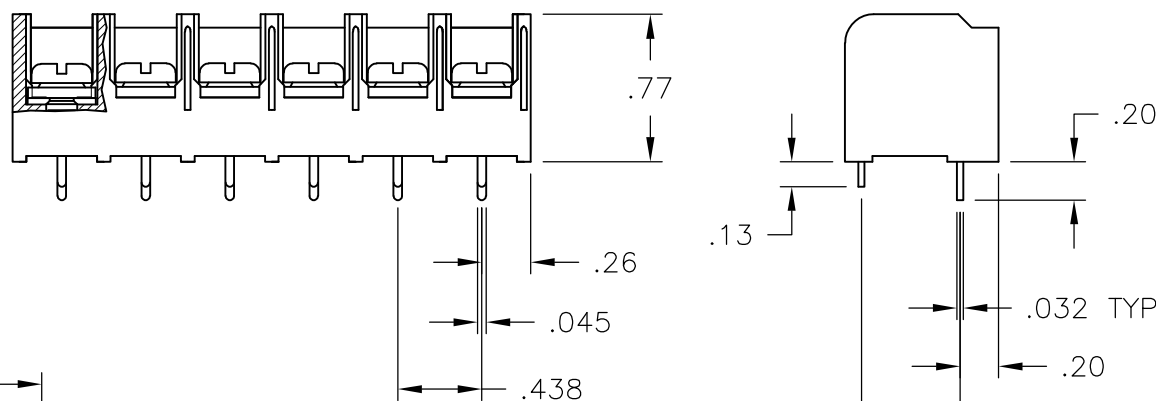
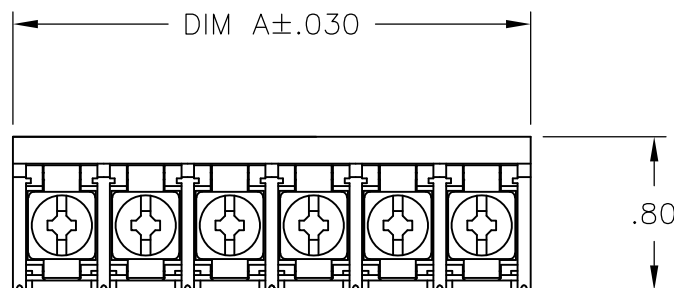







**ELECTRICAL:**  
 CURRENT RATING: 30A  
 VOLTAGE RATING: 600V  
 WIRE RANGE: 10-18 AWG (UL)  
 10-22 AWG (CSA)

**MECHANICAL:**  
 RECOMMENDED TORQUE: 20 IN-LB.  
 OPERATING TEMP.: -40°C TO +120°C MAX.

-  PRELIMINARY PART NUMBER.
-  TERMINAL TAPPED TO M4 WITH NO SCREWS



RECOMMENDED PCB LAYOUT

OBSOLETE	-9.698	22	8DBL-22-006	2-796709-2
OBSOLETE	-9.260	21	8DBL-21-006	2-796709-1
	8.823	20	8DBL-20-006	2-796709-0
	8.385	19	8DBL-19-006	1-796709-9
	7.948	18	8DBL-18-006	1-796709-8
	7.510	17	8DBL-17-006	1-796709-7
	7.073	16	8DBL-16-006	1-796709-6
	6.635	15	8DBL-15-006	1-796709-5
	6.198	14	8DBL-14-006	1-796709-4
	5.760	13	8DBL-13-006	1-796709-3
	5.323	12	8DBL-12-006	1-796709-2
	4.885	11	8DBL-11-006	1-796709-1
	4.448	10	8DBL-10-006	1-796709-0
	4.010	9	8DBL-09-006	796709-9
	3.573	8	8DBL-08-006	796709-8
	3.135	7	8DBL-07-002	796709-2
	3.135	7	8DBL-07-006	4-1546159-7
	2.698	6	8DBL-06-006	1-1437657-7
	2.260	5	8DBL-05-006	4-1546159-6
	1.823	4	8DBL-04-006	1-1437657-3
 OBSOLETE	-1.385	3	8DBL-03-649	1986428-1
	1.385	3	8DBL-03-006	1-1437657-1
	.948	2	8DBL-02-656	2-796709-3
	.948	2	8DBL-02-006	1437657-8
DIM A	NO OF POS	CATALOG NUMBER	TE PART NO.	

THIS DRAWING IS A CONTROLLED DOCUMENT.		DWN	S SCHLEGEL	6/20/03	 Tyco Electronics Corporation Harrisburg, PA 17105-3608												
DIMENSIONS: INCHES		CHK	S YODER	6/20/03													
TOLERANCES UNLESS OTHERWISE SPECIFIED:		APVD	S YODER	6/20/03													
<table border="0"> <tr> <td>0 PLC</td> <td>± -</td> </tr> <tr> <td>1 PLC</td> <td>± -</td> </tr> <tr> <td>2 PLC</td> <td>± .02</td> </tr> <tr> <td>3 PLC</td> <td>± .015</td> </tr> <tr> <td>4 PLC</td> <td>± -</td> </tr> <tr> <td>ANGLES</td> <td>± 1°</td> </tr> </table>		0 PLC	± -	1 PLC	± -	2 PLC	± .02	3 PLC	± .015	4 PLC	± -	ANGLES	± 1°	PRODUCT SPEC		NAME	
0 PLC	± -																
1 PLC	± -																
2 PLC	± .02																
3 PLC	± .015																
4 PLC	± -																
ANGLES	± 1°																
MATERIAL		APPLICATION SPEC		8DBL-XX-006 ASSEMBLY													
FINISH		WEIGHT	SIZE		CAGE CODE												
-		-	A3		00779												
		CUSTOMER DRAWING		DRAWING NO													
				G-1-1437657-1													
		SCALE		RESTRICTED TO													
		1:1		-													
		SHEET		REV													
		1 OF 1		F													