



Chipsmall Limited consists of a professional team with an average of over 10 year of expertise in the distribution of electronic components. Based in Hongkong, we have already established firm and mutual-benefit business relationships with customers from,Europe,America and south Asia,supplying obsolete and hard-to-find components to meet their specific needs.

With the principle of “Quality Parts,Customers Priority,Honest Operation,and Considerate Service”,our business mainly focus on the distribution of electronic components. Line cards we deal with include Microchip,ALPS,ROHM,Xilinx,Pulse,ON,Everlight and Freescale. Main products comprise IC,Modules,Potentiometer,IC Socket,Relay,Connector.Our parts cover such applications as commercial,industrial, and automotives areas.

We are looking forward to setting up business relationship with you and hope to provide you with the best service and solution. Let us make a better world for our industry!



Contact us

Tel: +86-755-8981 8866 Fax: +86-755-8427 6832

Email & Skype: info@chipsmall.com Web: www.chipsmall.com

Address: A1208, Overseas Decoration Building, #122 Zhenhua RD., Futian, Shenzhen, China



3M™ TWIN AXIAL PCI EXPRESS X16 MALE-TO-MALE CABLE ASSEMBLY

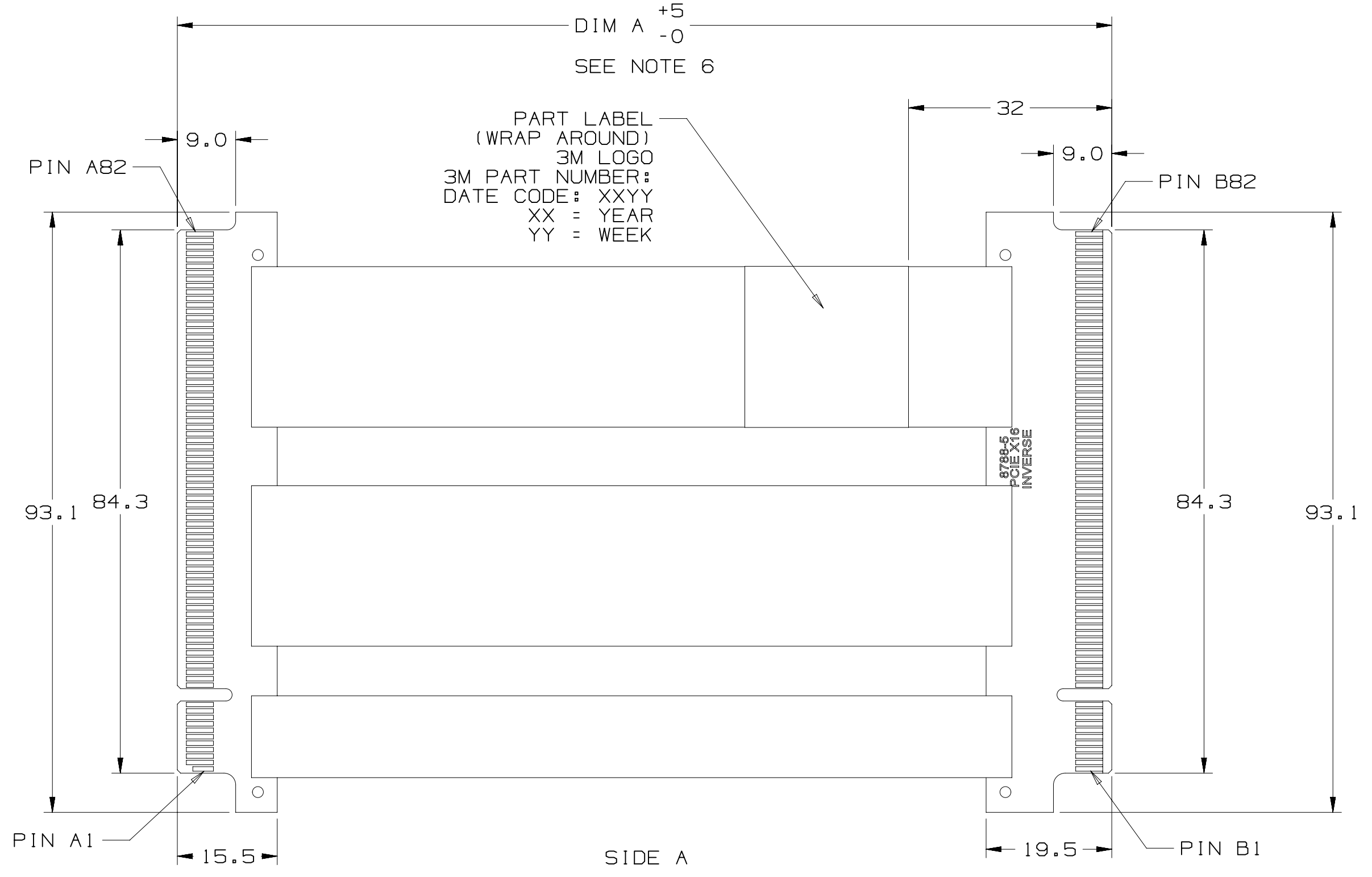
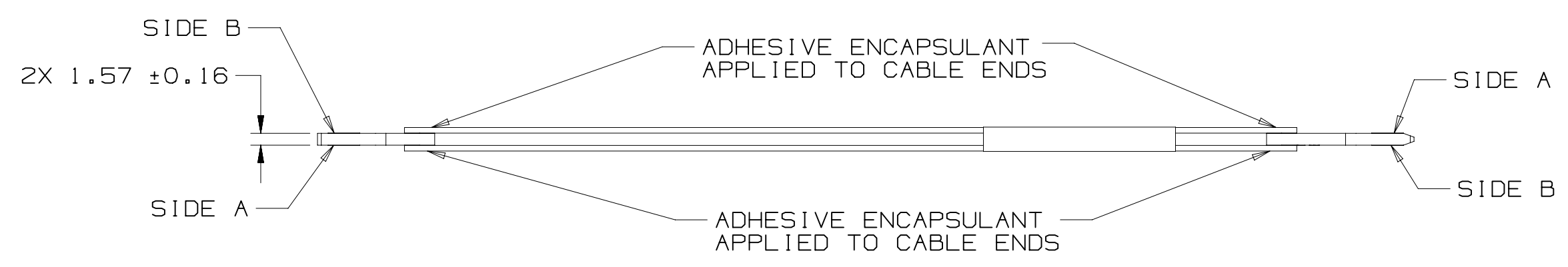
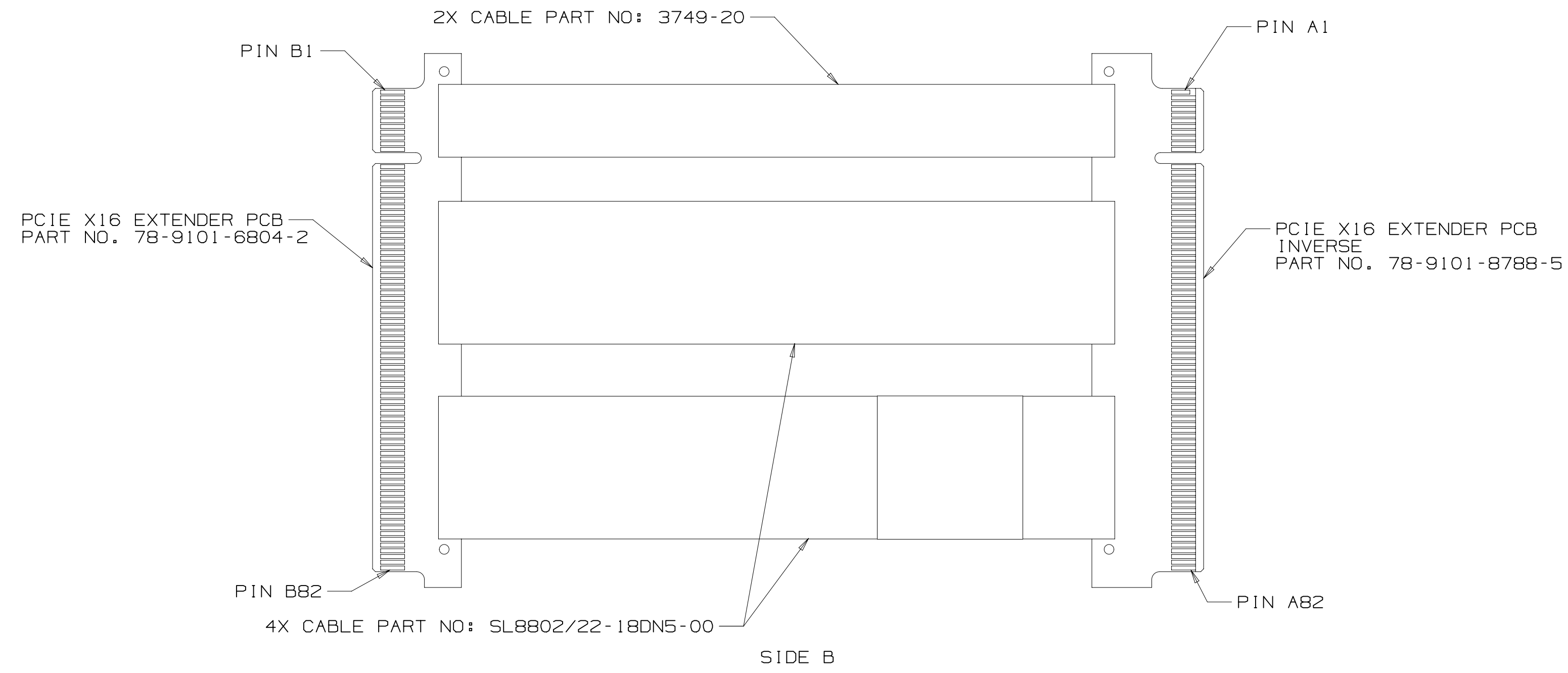

BILL OF MATERIALS			
ITEM	DESCRIPTION	QTY	
1.0	PCB PCIE X16 EXTENDER (164 POS) CARD-EDGE INVERSE 3M P/N: 78-9101-8788-5	1	
2.0	PCB PCIE X16 EXTENDER (164 POS) CARD-EDGE 3M P/N: 78-9101-6804-2	1	
3.0	CABLE RIBBON TWIN AX CABLE 3M P/N: SL8802/22-18DN5-00	4	
4.0	CABLE RIBBON CABLE, 20 POSITION 3M P/N: 3749-20	2	
5.0	STRAIN RELIEF ADHESIVE	AS REQUIRED	

- NOTES
- DIMENSIONS ARE IN MILLIMETERS.
 - 3M™ RIBBON TWINAX DESCRIPTION:
30 AWG, SILVER PLATED SIGNAL WIRE
IMPEDANCE: 85 ±5 OHM
OVERALL RIBBON WIDTH: 24.90 MM
OVERALL RIBBON THICKNESS: 0.75 MM
 - ROHS COMPLIANT. SEE REGULATORY INFORMATION APPENDIX IN "ROHS COMPLIANCE" SECTION AT WWW.3MCONNECTORS.COM (E1 & C1 APPLY)
 - THIS CABLE CONSTRUCTION HAS A THIN ALUMINUM LAYER AT EACH EDGE. USER SHOULD EVALUATE ITS USE IN THEIR APPLICATION AND, IF NECESSARY, INSULATING TAPE MAY BE APPLIED TO COVER THE ALUMINUM LAYER, AS USER DEEMS APPROPRIATE.
 - APPLICABLE SPECIFICATIONS:
PRODUCT SPECIFICATION NUMBER:
TWIN AX CABLE: PS-0106
CABLE ASSEMBLY: PS-0137
 - ORDER BY APPLICABLE 3M PART NUMBER:
8KC5-0742-XXXX
XXXX = DIM 'A' IN MILLIMETERS (1000 = 1 METER)

STANDARD LENGTH (DIM 'A')
8KC5-0742-0250 (250 MM)
8KC5-0742-0500 (500 MM)

NON-STANDARD LENGTHS AVAILABLE UPON SPECIAL REQUEST. MAY REQUIRE HIGHER MOQS AND LONGER LEAD TIMES.
 - FLAMMABILITY RATING:
TWIN AX CABLE: UL94 HB
PCBS: UL94V-0
 - PADDLECARD FINGER GOLD THICKNESS:
0.76 μm [30 μ"] MIN ELECTROLYTIC
HARD GOLD OVER 1.27 μm [50 μ"]
MIN ELECTROLYTIC NICKEL.

REV	ECO	ISSUE DATE AND DESCRIPTION	DRFT	CHKD
B	48418	JUN 19, 2013 ADDED SIDE A & SIDE B INDICATORS	LDS	TS
A	46893	MAR 27, 2013 WORK REQUEST 11618 INITIAL RELEASE	LDS	TS

DESIGN REFERENCE	NEXT ASSEMBLY	REV	ECO	ISSUE DATE AND DESCRIPTION	DRFT	CHKD
DO NOT SCALE DRAWING	SCALE 1/1	TOLERANCES EXCEPT AS NOTED				
THIRD ANGLE PROJECTION	INTERPRET PER ASME Y14.5 - 1994	MILLIMETERS 0 ± 1	TITLE 8KC5-0742-XXXX, CABLE ASSY, MALE PCIE X16 TO MALE PCIE X16			
MAX SURFACE ROUGHNESS 125	ALL SURFACES MARKED ONLY	INCHES .00 ± .0000	CAGE NUMBER	SIZE	DRAWING NO.	REV.
		ANGLES ± 1°	D	78-5100-2586-5	B	B

78-5100-2586-5 DRAWING NUMBER
 B REVISION
 A UTC-05:00
 6/19/2013 9:50 AM

3M 3749-20 Cable	
Wire #	Pin Attachment #
01	Ground Layer
02	B01 - B02
03	B01 - B02
04	B01 - B02
05	B01 - B02
06	B01 - B02
07	B01 - B02
08	Ground Layer
09	B05
10	B06
11	Ground Layer
12	B08
13	B08
14	B09
15	B10
16	B10
17	Ground Layer
18	B11
19	Ground Layer
20	B12

3M SL8802 Cable	
Wire #	Pin Attachment
GND	Ground Layer
pr_01	B14
pr_01	B15
pr_02	B17
pr_02	Ground Layer
pr_03	B19
pr_03	B20
pr_04	B23
pr_04	B24
GND	Ground Layer
pr_05	B27
pr_05	B28
pr_06	B30
pr_06	B31
pr_07	B33
pr_07	B34
GND	Ground Layer
pr_08	B37
pr_08	B38
pr_09	B41
pr_09	B42
pr_10	B45
pr_10	B46
pr_11	B48
pr_11	Ground Layer
GND	Ground Layer

3M SL8802 Cable	
Wire #	Pin Attachment #
GND	Ground Layer
pr_01	B50
pr_01	B51
pr_02	Ground Layer
pr_02	Ground Layer
pr_03	B54
pr_03	B55
pr_04	B58
pr_04	B59
GND	Ground Layer
pr_05	B62
pr_05	B63
pr_06	B66
pr_06	B67
pr_07	B70
pr_07	B71
GND	Ground Layer
pr_08	B74
pr_08	B75
pr_09	Ground Layer
pr_09	Ground Layer
pr_10	B78
pr_10	B79
pr_11	B81
pr_11	B82
GND	Ground Layer

PCI-Express X16 Pin-Out			
Pin #	Side B Description	Side A Description	Pin #
B01	+12 volt power	Hot plug presence detect	A01
B02	+12 volt power	+12 volt power	A02
B03	+12 volt power	+12 volt power	A03
B04	Ground	Ground	A04
B05	SMBus clock	TCK	A05
B06	SMBus data	TDI	A06
B07	Ground	TD0	A07
B08	+3.3 volt power	TMS	A08
B09	+TRST#	+3.3 volt power	A09
B10	3.3v volt power	+3.3 volt power	A10
B11	Link Reactivation	Power Good	A11
Mechanical Key			
B12	Reserved	Ground	A12
B13	Ground	Reference Clock	A13
B14	Transmitter Lane 0,	Differential pair	A14
B15	Differential pair	Ground	A15
B16	Ground	Receiver Lane 0,	A16
B17	Hotplug detect	Differential pair	A17
B18	Ground	Ground	A18
B19	Transmitter Lane 1,	Reserved	A19
B20	Differential pair	Ground	A20
B21	Ground	Receiver Lane 1,	A21
B22	Ground	Differential pair	A22
B23	Transmitter Lane 2,	Ground	A23
B24	Differential pair	Ground	A24
B25	Ground	Receiver Lane 2,	A25
B26	Ground	Differential pair	A26
B27	Transmitter Lane 3,	Ground	A27
B28	Differential pair	Ground	A28
B29	Ground	Receiver Lane 3,	A29
B30	Reserved	Differential pair	A30
B31	Hot plug detect	Ground	A31
B32	Ground	Reserved	A32
B33	Transmitter Lane 4,	Reserved	A33
B34	Differential pair	Ground	A34
B35	Ground	Receiver Lane 4,	A35
B36	Ground	Differential pair	A36
B37	Transmitter Lane 5,	Ground	A37
B38	Differential pair	Ground	A38
B39	Ground	Receiver Lane 5,	A39
B40	Ground	Differential pair	A40
B41	Transmitter Lane 6,	Ground	A41
B42	Differential pair	Ground	A42
B43	Ground	Receiver Lane 6,	A43
B44	Ground	Differential pair	A44
B45	Transmitter Lane 7,	Ground	A45
B46	Differential pair	Ground	A46
B47	Ground	Receiver Lane 7,	A47
B48	Hot plug detect	Differential pair	A48
B49	Ground	Ground	A49
B50	Transmitter Lane 8,	Reserved	A50
B51	Differential pair	Ground	A51
B52	Ground	Receiver Lane 8,	A52
B53	Ground	Differential pair	A53
B54	Transmitter Lane 9,	Ground	A54
B55	Differential pair	Ground	A55
B56	Ground	Receiver Lane 9,	A56
B57	Ground	Differential pair	A57
B58	Transmitter Lane 10,	Ground	A58
B59	Differential pair	Ground	A59
B60	Ground	Receiver Lane 10,	A60
B61	Ground	Differential pair	A61
B62	Transmitter Lane 11,	Ground	A62
B63	Differential pair	Ground	A63
B64	Ground	Receiver Lane 11,	A64
B65	Ground	Differential pair	A65
B66	Transmitter Lane 12,	Ground	A66
B67	Differential pair	Ground	A67
B68	Ground	Receiver Lane 12,	A68
B69	Ground	Differential pair	A69
B70	Transmitter Lane 13,	Ground	A70
B71	Differential pair	Ground	A71
B72	Ground	Receiver Lane 13,	A72
B73	Ground	Differential pair	A73
B74	Transmitter Lane 14,	Ground	A74
B75	Differential pair	Ground	A75
B76	Ground	Receiver Lane 14,	A76
B77	Ground	Differential pair	A77
B78	Transmitter Lane 15,	Ground	A78
B79	Differential pair	Ground	A79
B80	Ground	Receiver Lane 15,	A80
B81	Hot plug present detect	Differential pair	A81
B82	Hot Plug Detect	Ground	A82

3M 3749-20 Cable	
Pin Attachment #	Wire #
Ground Layer	01
A01	02
Ground Layer	03
A02 - A03	04
A02 - A03	05
A02 - A03	06
A02 - A03	07
Ground Layer	08
A05	09
A06	10
A07	11
A08	12
Ground Layer	13
A09 - A10	14
A09 - A10	15
A09 - A10	16
A09 - A10	17
Ground Layer	18
Ground Layer	19
A11	20

3M SL8802 Cable	
Pin Attachment #	Wire #
Ground Layer	GND
A13	pr_01
A14	pr_01
A16	pr_02
A17	pr_02
Ground Layer	pr_03
A19	pr_03
A21	pr_04
A22	pr_04
Ground Layer	GND
A25	pr_05
A26	pr_05
A29	pr_06
A30	pr_06
A32	pr_07
A33	pr_07
Ground Layer	GND
A35	pr_08
A36	pr_08
A39	pr_09
A40	pr_09
A43	pr_10
A44	pr_10
A47	pr_11
A48	pr_11
Ground Layer	GND

3M SL8802 Cable	
Pin Attachment #	Wire #
Ground Layer	GND
A33	pr_01
Ground Layer	pr_01
A52	pr_02
A53	pr_02
Ground Layer	pr_03
Ground Layer	pr_03
A56	pr_04
A57	pr_04
Ground Layer	GND
A60	pr_05
A61	pr_05
A64	pr_06
A65	pr_06
A68	pr_07
A69	pr_07
Ground Layer	GND
A72	pr_08
A73	pr_08
A76	pr_09
A77	pr_09
Ground Layer	pr_10
Ground Layer	pr_10
A80	pr_11
A81	pr_11
Ground Layer	GND

DESIGN REFERENCE	NEXT ASSEMBLY	REV	ECO	ISSUE DATE AND DESCRIPTION	DRFT	CHKD
DIVISION		DIVISION CODE		DATE		
				DATE		
DO NOT SCALE DRAWING		SCALE 1/1		TOLERANCES EXCEPT AS NOTED		
				INCHES		
				MILLIMETERS		
THIRD ANGLE PROJECTION				INTERPRET PER ASME Y14.5 - 1994		
				MAX SURFACE ROUGHNESS		
				ALL SURFACES		
				MARKED ONLY		
				ANGLES ±1°		

B 48418	JUN 19, 2013	LDS	TS	
ADDED SIDE A & SIDE B INDICATORS				
A 46893	MAR 27, 2013	LDS	TS	
WORK REQUEST 11618 INITIAL RELEASE				
REV	ECO	ISSUE DATE AND DESCRIPTION	DRFT	CHKD
1		MAR 27, 2013		
2		MAR 28, 2013		

© 3M COPYR[IGHT] 2013
 This document and the information it contains are 3M property and may not be reproduced or further distributed without 3M permission, or used or disclosed other than for 3M authorized purposes. All rights reserved.

TITLE	8KC5-0742-XXXX, CABLE ASSY, MALE PCIE X16 TO MALE PCIE X16
CAGE NUMBER	D 78-5100-2586-5
SIZE	B
DRAWING NO.	78-5100-2586-5
REV.	B
MODEL	IST1
YES	NO
SHT 2 OF 2	

B REVISION
 78-5100-2586-5 DRAWING NUMBER
 B
 A
 Imaged: B.1 6/19/2013 9:50 AM UTC-05:00