



Chipsmall Limited consists of a professional team with an average of over 10 year of expertise in the distribution of electronic components. Based in Hongkong, we have already established firm and mutual-benefit business relationships with customers from,Europe,America and south Asia,supplying obsolete and hard-to-find components to meet their specific needs.

With the principle of "Quality Parts,Customers Priority,Honest Operation,and Considerate Service",our business mainly focus on the distribution of electronic components. Line cards we deal with include Microchip,ALPS,ROHM,Xilinx,Pulse,ON,Everlight and Freescale. Main products comprise IC,Modules,Potentiometer,IC Socket,Relay,Connector.Our parts cover such applications as commercial,industrial, and automotives areas.

We are looking forward to setting up business relationship with you and hope to provide you with the best service and solution. Let us make a better world for our industry!



Contact us

Tel: +86-755-8981 8866 Fax: +86-755-8427 6832

Email & Skype: info@chipsmall.com Web: www.chipsmall.com

Address: A1208, Overseas Decoration Building, #122 Zhenhua RD., Futian, Shenzhen, China



LOC	DIST	REV	DATE	BY	CHK	APPV
GP	00					
		4	08DEC2010	WS	MH	
		5	10MAY2012	REH	DT	

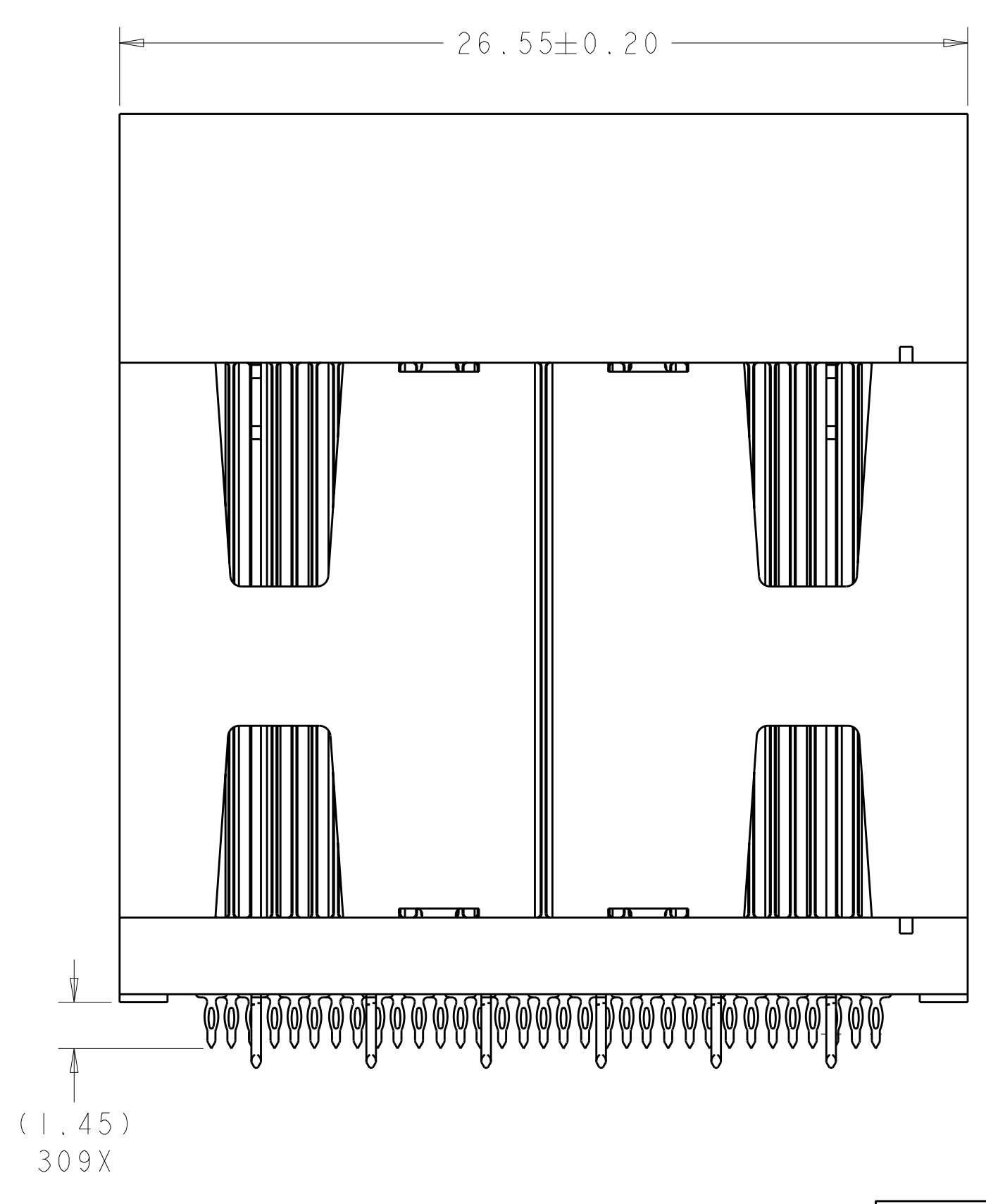
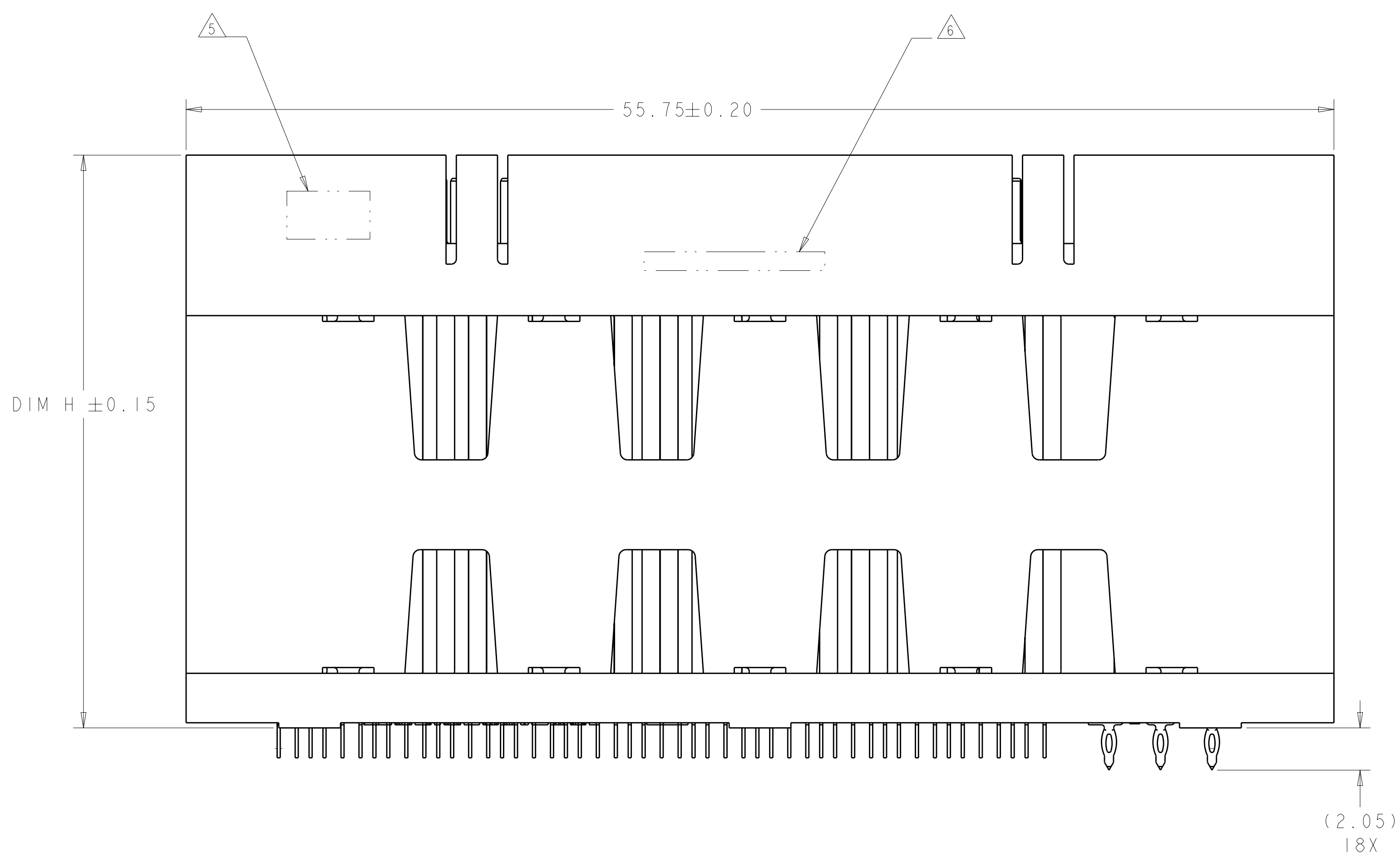
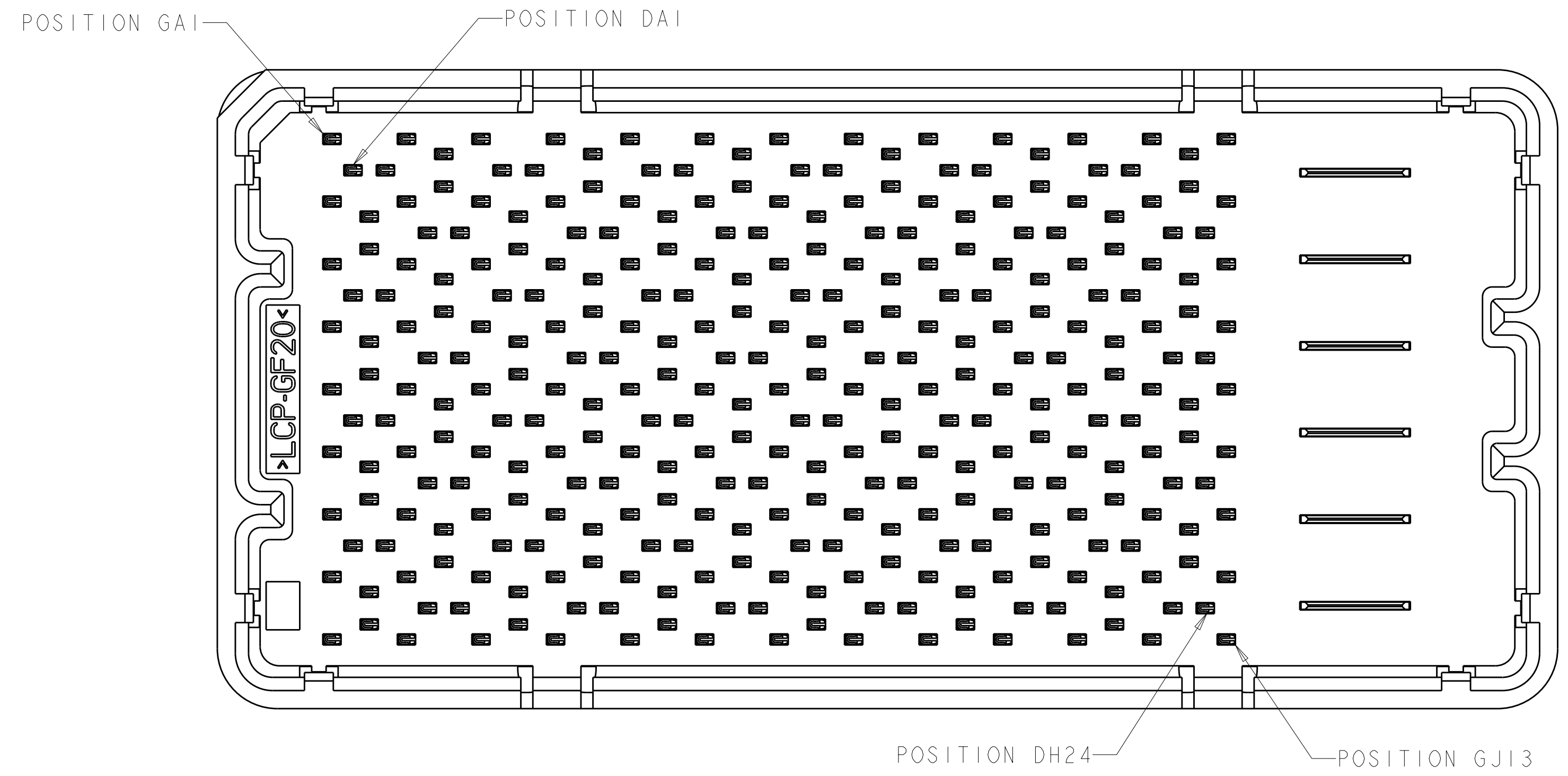

- 1. MATERIAL:
 BASE HOUSING, UPPER HOUSING, ORGANIZER, AND SPACER: THERMOPLASTIC, FLAMMABILITY RATING UL94-V0
 CONTACT: COPPER ALLOY
- 2. CONFORMS TO THE REQUIREMENTS OF TE PRODUCT SPECIFICATION, 108-2375; BASED ON TELCORDIA GR-1217-CORE FOR SYSTEM QUALITY LEVEL III, APPLICATIONS IN CONTROLLED ENVIRONMENTS (CENTRAL OFFICE). SEE TE PRODUCT SPECIFICATION 108-2375 FOR TEST SEQUENCES.
- 3. ROWS GA THRU GJ (SHOWN DARKENED) ARE TYPICALLY USED AS GROUNDS.
- 4. SPECIFIED POSITIONAL TOLERANCE DEFINES HOLE TO HOLE LOCATION WITHIN HOLE PATTERN. POSITIONAL TOLERANCE OF HOLE PATTERN TO FIDUCIAL MARKS OR PCB DATUMS SHALL BE DEFINED BY CUSTOMER.
- 5. AREA RESERVED FOR TE CONNECTIVITY LOGO.
- 6. AREA RESERVED FOR PART NUMBER (X-XXXXXX-X) AND DATE CODE (YYWW).
- 7. USE CENTERLINES INDICATED ON PCB HOLE PATTERN TO ESTABLISH ALIGNMENT BETWEEN HEADER AND RECEPTACLE BOARDS.
- 8. PLATED THROUGH HOLE REQUIREMENTS - SIGNAL:
 HOLE SIZE PRIOR TO PLATING = $\varnothing 0.420 \pm 0.013$
 COPPER PLATING THICKNESS = 0.038 ± 0.013
 CALCULATED FINISHED HOLE SIZE = $\varnothing 0.344 \pm 0.039$
 THESE DIMENSIONS APPLY TO THE TOP 1.25mm OF THE PCB THICKNESS FROM THE CONNECTOR MOUNTING SIDE.
- 9. PLATED THROUGH HOLE REQUIREMENTS - POWER:
 HOLE SIZE PRIOR TO PLATING = $\varnothing 0.700 \pm 0.025$
 COPPER PLATING THICKNESS = 0.038 ± 0.013
 CALCULATED FINISHED HOLE SIZE = $\varnothing 0.624 \pm 0.051$
 THESE DIMENSIONS APPLY TO THE TOP 1.50mm OF THE PCB THICKNESS FROM THE CONNECTOR MOUNTING SIDE.
- 10. CONTACT SALES FOR AVAILABILITY OF THIS STACK HEIGHT.

SIZE 3 HOUSING *
96 DIFFERENTIAL PAIRS
309 TOTAL SIGNAL CONTACTS
6 POWER CONTACTS

* SIZE 1 AND SIZE 2 ARE ALSO AVAILABLE

THIS PRODUCT HAS NOT COMPLETED VALIDATION AND QUALIFICATION TESTING

THIS DRAWING IS A CONTROLLED DOCUMENT.		OWN: D. RINGLER 08JUN2009	TE Connectivity	
DIMENSIONS: mm		CHK: D. TROUT 08JUN2009		
TOLERANCES UNLESS OTHERWISE SPECIFIED:		APPV: J. FEDDER 08JUN2009	NAME: HEADER ASSEMBLY 96/309/6P	
0 PLC ±	1 PLC ±0.13	PRODUCT SPEC: 108-2375	STRADA MESA MEZZANINE CONNECTOR	
2 PLC ±0.13	3 PLC ±0.013	APPLICATION SPEC: 114-13249	SIZE: CAGE CODE: DRAWING NO: RESTRICTED TO	
4 PLC ±	ANGLES ±#1	WEIGHT: -	A100779C=2110480	
MATERIAL: -		CUSTOMER DRAWING	SCALE: 6:1 SHEET 1 OF 4 REV 5	

LOC	DIST	REV	DATE	BY	APPD
GP	00				
DESCRIPTION			DATE	BY	APPD
SEE SHEET 1					

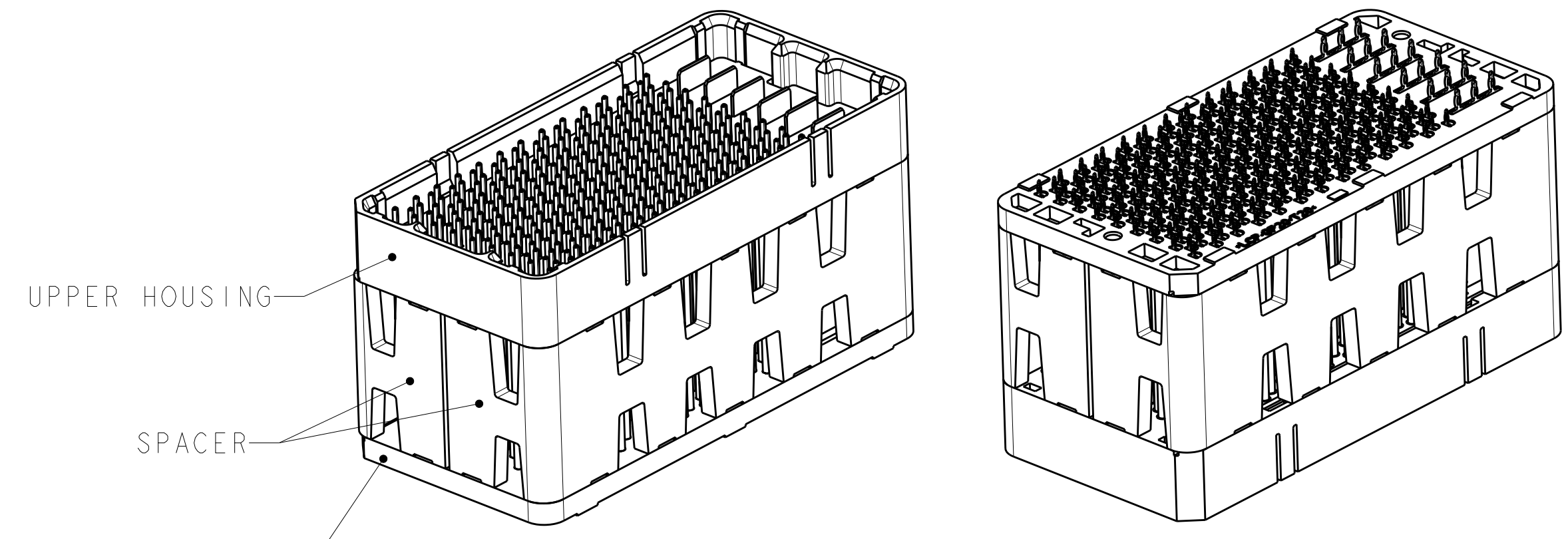

ISOMETRIC VIEW
 TYPICAL CONFIGURATION FOR 14mm THRU 42mm
 28mm SHOWN
 SCALE 2:1

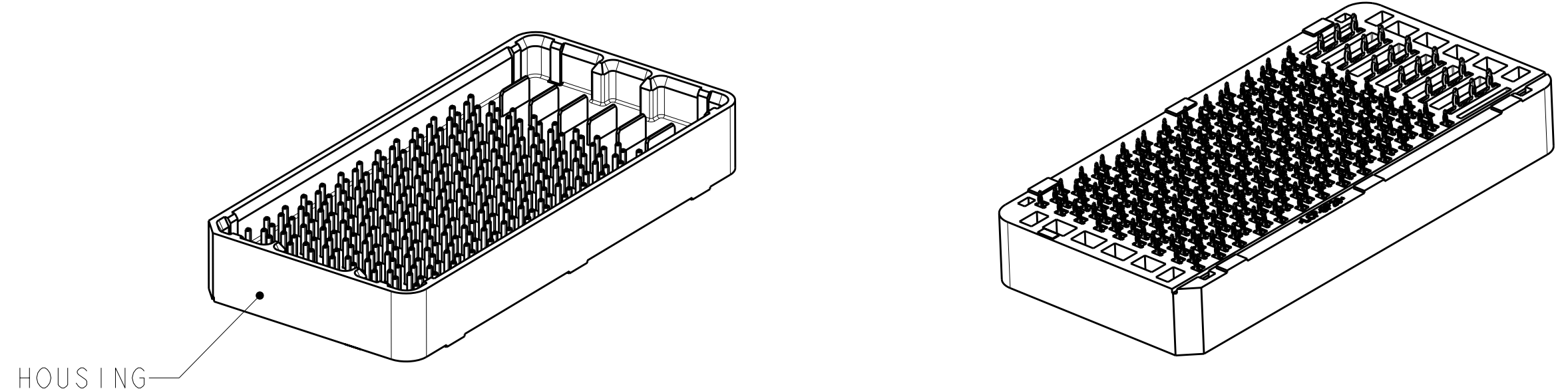

ISOMETRIC VIEWS
 TYPICAL CONFIGURATION FOR 8mm THRU 13mm
 8mm SHOWN
 SCALE 2:1

TOOLED	DIM H	STACK HEIGHT	CONTACT TAIL PLATING	PART NUMBER
△10	41.8	42mm	MATTE Sn	9-2110480-2
△10	40.8	41mm	MATTE Sn	9-2110480-1
YES	39.8	40mm	MATTE Sn	9-2110480-0
△10	38.8	39mm	MATTE Sn	8-2110480-9
△10	37.8	38mm	MATTE Sn	8-2110480-8
△10	36.8	37mm	MATTE Sn	8-2110480-7
△10	35.8	36mm	MATTE Sn	8-2110480-6
△10	34.8	35mm	MATTE Sn	8-2110480-5
△10	33.8	34mm	MATTE Sn	8-2110480-4
△10	32.8	33mm	MATTE Sn	8-2110480-3
△10	31.8	32mm	MATTE Sn	8-2110480-2
△10	30.8	31mm	MATTE Sn	8-2110480-1
△10	29.8	30mm	MATTE Sn	8-2110480-0
△10	28.8	29mm	MATTE Sn	7-2110480-9
YES	27.8	28mm	MATTE Sn	7-2110480-8
△10	26.8	27mm	MATTE Sn	7-2110480-7
△10	25.8	26mm	MATTE Sn	7-2110480-6
△10	24.8	25mm	MATTE Sn	7-2110480-5
△10	23.8	24mm	MATTE Sn	7-2110480-4
YES	22.8	23mm	MATTE Sn	7-2110480-3
△10	21.8	22mm	MATTE Sn	7-2110480-2
△10	20.8	21mm	MATTE Sn	7-2110480-1
△10	19.8	20mm	MATTE Sn	7-2110480-0
△10	18.8	19mm	MATTE Sn	6-2110480-9
△10	17.8	18mm	MATTE Sn	6-2110480-8
△10	16.8	17mm	MATTE Sn	6-2110480-7
△10	15.8	16mm	MATTE Sn	6-2110480-6
△10	14.8	15mm	MATTE Sn	6-2110480-5
△10	13.8	14mm	MATTE Sn	6-2110480-4
△10	12.8	13mm	MATTE Sn	6-2110480-3
△10	11.8	12mm	MATTE Sn	6-2110480-2
△10	10.8	11mm	MATTE Sn	6-2110480-1
YES	9.8	10mm	MATTE Sn	6-2110480-0
△10	8.8	9mm	MATTE Sn	5-2110480-9
△10	7.8	8mm	MATTE Sn	5-2110480-8

TOOLED	DIM H	STACK HEIGHT	CONTACT TAIL PLATING	PART NUMBER
△10	41.8	42mm	Sn/Pb	4-2110480-2
△10	40.8	41mm	Sn/Pb	4-2110480-1
YES	39.8	40mm	Sn/Pb	4-2110480-0
△10	38.8	39mm	Sn/Pb	3-2110480-9
△10	37.8	38mm	Sn/Pb	3-2110480-8
△10	36.8	37mm	Sn/Pb	3-2110480-7
△10	35.8	36mm	Sn/Pb	3-2110480-6
△10	34.8	35mm	Sn/Pb	3-2110480-5
△10	33.8	34mm	Sn/Pb	3-2110480-4
△10	32.8	33mm	Sn/Pb	3-2110480-3
△10	31.8	32mm	Sn/Pb	3-2110480-2
△10	30.8	31mm	Sn/Pb	3-2110480-1
△10	29.8	30mm	Sn/Pb	3-2110480-0
△10	28.8	29mm	Sn/Pb	2-2110480-9
YES	27.8	28mm	Sn/Pb	2-2110480-8
△10	26.8	27mm	Sn/Pb	2-2110480-7
△10	25.8	26mm	Sn/Pb	2-2110480-6
△10	24.8	25mm	Sn/Pb	2-2110480-5
△10	23.8	24mm	Sn/Pb	2-2110480-4
YES	22.8	23mm	Sn/Pb	2-2110480-3
△10	21.8	22mm	Sn/Pb	2-2110480-2
△10	20.8	21mm	Sn/Pb	2-2110480-1
△10	19.8	20mm	Sn/Pb	2-2110480-0
△10	18.8	19mm	Sn/Pb	1-2110480-9
△10	17.8	18mm	Sn/Pb	1-2110480-8
△10	16.8	17mm	Sn/Pb	1-2110480-7
△10	15.8	16mm	Sn/Pb	1-2110480-6
△10	14.8	15mm	Sn/Pb	1-2110480-5
△10	13.8	14mm	Sn/Pb	1-2110480-4
△10	12.8	13mm	Sn/Pb	1-2110480-3
△10	11.8	12mm	Sn/Pb	1-2110480-2
△10	10.8	11mm	Sn/Pb	1-2110480-1
YES	9.8	10mm	Sn/Pb	1-2110480-0
△10	8.8	9mm	Sn/Pb	2110480-9
△10	7.8	8mm	Sn/Pb	2110480-8

THIS DRAWING IS A CONTROLLED DOCUMENT. DWG: D. RINGLER 08JUN2009
 CHK: D. TROUT 08JUN2009
 APVD: J. FEDDER 08JUN2009

STE TE Connectivity

NAME: HEADER ASSEMBLY
 96/309/6P
 STRADA MESA MEZZANINE CONNECTOR

PRODUCT SPEC: 108-2375
 APPLICATION SPEC: 114-13249

SIZE: A100779C=2110480
 SCALE: 6:1 SHEET 2 OF 4 REV 5

LOC	DIST	REVISIONS			
GP	00	REV	DATE	BY	APPD
		1	SEE SHEET 1		

AI CORNER INDICATORS.

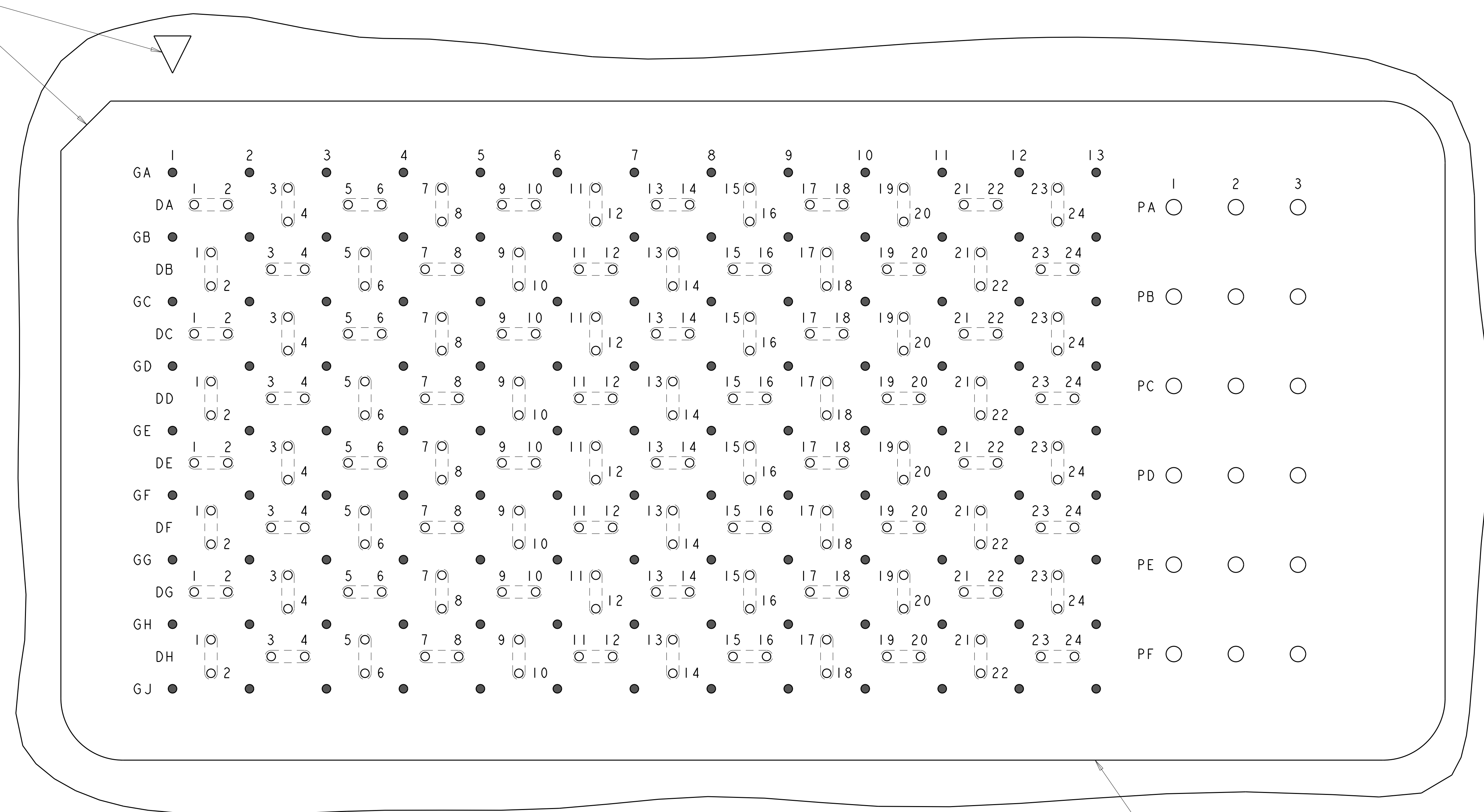

MATED CONNECTOR OUTLINE
 SEE SHEET 4 FOR LOCATION TO HOLES

PCB LAYOUT AND PIN IDENTIFICATION 
 SHOWN FROM CONNECTOR SIDE
 SCALE 10:1

THIS DRAWING IS A CONTROLLED DOCUMENT.		DWN D. RINGLER 08JUN2009	 TE Connectivity
DIMENSIONS: mm		CHK D. TROUT 08JUN2009	
TOLERANCES UNLESS OTHERWISE SPECIFIED:		APVD J. FEDDER 08JUN2009	NAME HEADER ASSEMBLY 96/309/6P
9 PLC ± 3 PLC ±0.13 5 PLC ±0.013 4 PLC ± ANGLES ±1		PRODUCT SPEC 108-2375	APPLICATION SPEC STRADA MESA MEZZANINE CONNECTOR
MATERIAL		114-13249	RESTRICTED TO
FINISH		WEIGHT	SIZE CAGE CODE DRAWING NO A100779C=2110480
		CUSTOMER DRAWING	SCALE 6:1 SHEET 3 OF 4 REV 5

LOC	DIST	REV	DATE	BY	APPD
GP	00				

REVISIONS		DATE	BY	APPD
1	SEE SHEET 1			

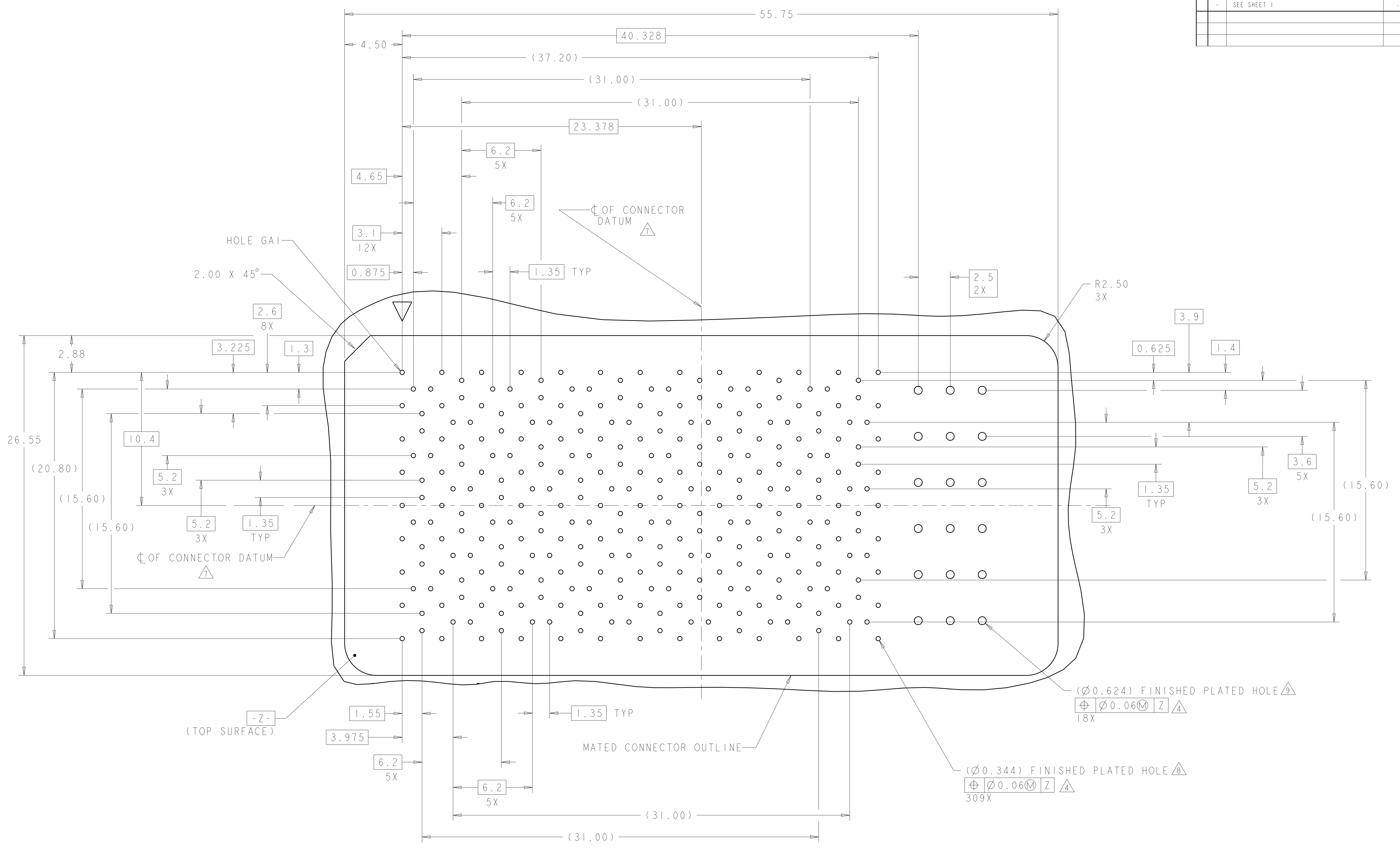

THIS DRAWING IS A CONTROLLED DOCUMENT.		DWN D. RINGLER 08JUN2009	TE Connectivity
DIMENSIONS: mm		CHK D. TROUT 08JUN2009	
TOLERANCES UNLESS OTHERWISE SPECIFIED:		APVD J. FEDDER 08JUN2009	NAME HEADER ASSEMBLY 96/309/6P
0 PLC ± 1 PLC ±0.13 3 PLC ±0.013 4 PLC ± ANGLES ±1		PRODUCT SPEC 108-2375	APPLICATION SPEC STRADA MESA MEZZANINE CONNECTOR
MATERIAL: -		114-13249	RESTRICTED TO
FINISH: -		WEIGHT: -	SIZE CAGE CODE DRAWING NO A100779C=2110480
		CUSTOMER DRAWING	SCALE 6:1 SHEET 4 OF 4 REV 5