



Chipsmall Limited consists of a professional team with an average of over 10 year of expertise in the distribution of electronic components. Based in Hongkong, we have already established firm and mutual-benefit business relationships with customers from,Europe,America and south Asia,supplying obsolete and hard-to-find components to meet their specific needs.

With the principle of “Quality Parts,Customers Priority,Honest Operation,and Considerate Service”,our business mainly focus on the distribution of electronic components. Line cards we deal with include Microchip,ALPS,ROHM,Xilinx,Pulse,ON,Everlight and Freescale. Main products comprise IC,Modules,Potentiometer,IC Socket,Relay,Connector.Our parts cover such applications as commercial,industrial, and automotives areas.

We are looking forward to setting up business relationship with you and hope to provide you with the best service and solution. Let us make a better world for our industry!



## Contact us

Tel: +86-755-8981 8866 Fax: +86-755-8427 6832

Email & Skype: info@chipsmall.com Web: www.chipsmall.com

Address: A1208, Overseas Decoration Building, #122 Zhenhua RD., Futian, Shenzhen, China





MAKER WORKS TECHNOLOGY INC

Technical support: [support@makeblock.cc](mailto:support@makeblock.cc)

[www.makeblock.cc](http://www.makeblock.cc)



:@Makeblock



: @Makeblock



: +Makeblock



# Starter Robot Kit **IR Version**

Robot Tank

Three-Wheeled Robot Car

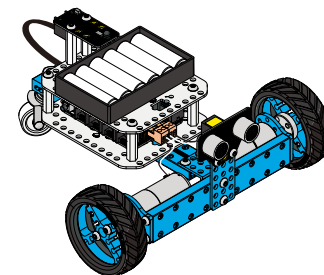
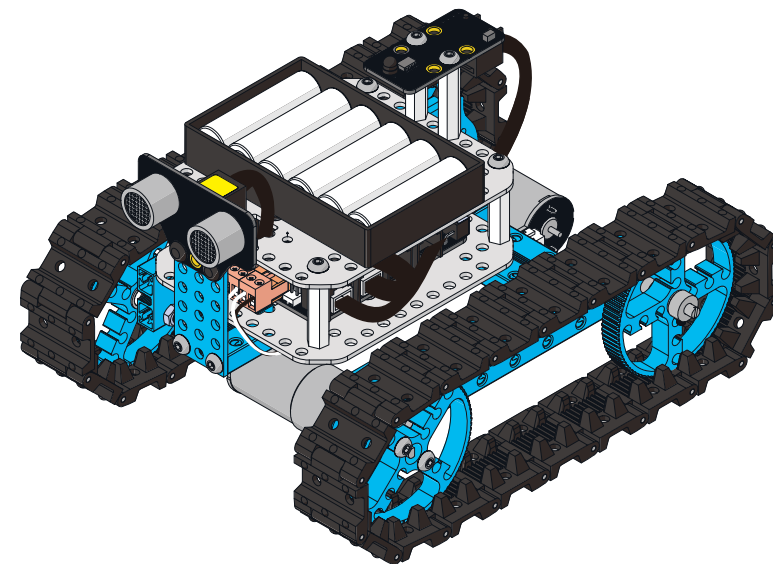

# Quick Guide

Warning: Keep this kit out of the reach of small children or animals. Small parts may cause choking or serious injury if swallowed.

Makeblock Starter Robot Kit contains mechanical parts and electronic modules for you to start exploring the robot world which can be used to build a robot tank or a three-wheel robot car. It is also a great tool to learn mBlock and Scratch programming.



Please visit

<http://learn.makeblock.cc/starter-robot-kit/>

to view the build and programming guide.



Parts List



Check all components in parts list, please contact Makeblock or the distributor if any component lacked.

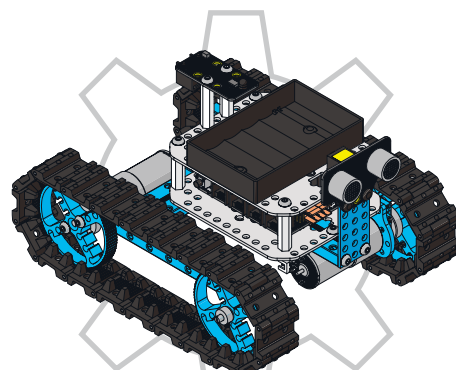

Build the Robot Tank



Follow our manual to build the Robot Tank.

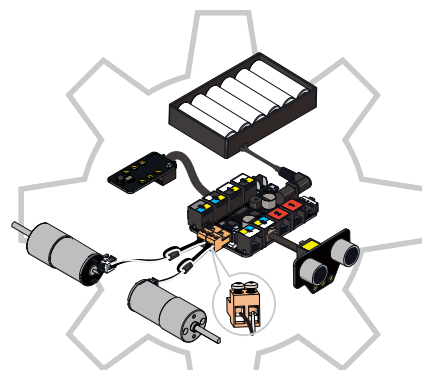

Wiring



Do wiring. Install batteries for your robot and remote control.

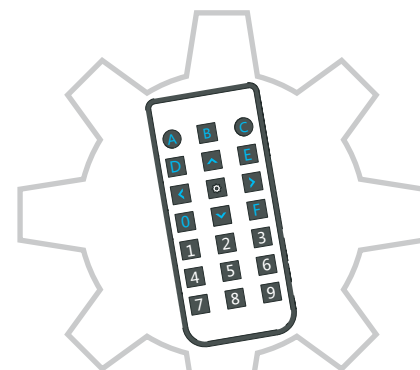

Remote control



Turn on the power of your robot, control your robot with remote control. **Now it's time to play your robot!**

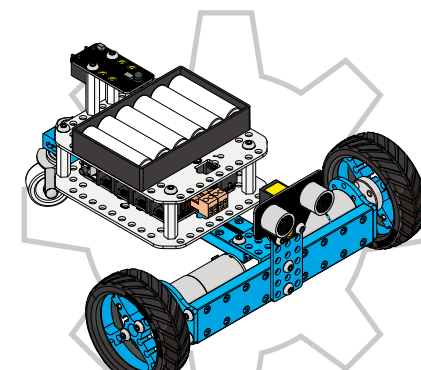

Build three-wheeled Robot Car



Try another style: Follow our manual to build the Three-wheeled Robot Car.



Programming Guide—Further exploration



Advanced player can re-program to the robot by mBlock or Arduino to explore the wonderful robotic world.

# Parts List

Pictures for reference only

1× Beam 0824-96



1× Beam 0824-128



2× Beam 0824-144



1× Bracket 3×3



1× Plate 3×6



1× Bracket P3



1× Caster Wheel



1× Nut M8



2× DC Motor-25 Bracket



2× Shaft Connector 4mm



4× Timing Pulley 90T



2× Tire 68.5×22mm



36× Track



36× Track Axle



2× Threaded Shaft 4×39mm



2× Shaft Collar 4mm



4× Flange Bearing 4×8×3mm



1× Hex Screwdriver



1× Cross Screwdriver



1× Hex Allen Key 2.5mm



2× Hex Allen Key 1.5mm



1× Wrench



20× Screw M4×8



12× Screw M4×14



4× Screw M4×22



12× Nut M4



4× Headless Set Screw M3×5



4× Screw M3×8



6× Plastic Ring 4×7×2mm



6× Nylon Stud M4×30



2× BaseBracket



1× Battery Holder for (6) AA



2× DC Motor-25



2× Terminal Block



2× Motor Cable



2× Ferrite Ring



1× Makeblock Orion



1× Me Ultrasonic Sensor



1× Me Infrared Receiver Sensor



1× Me IR Remote Controller



1× Micro USB cable



1× 6P6C RJ25 Cable-20cm



1× 6P6C RJ25 Cable-35cm



# Tool Tips

Hex Screwdriver



Hex Allen Key 2.5mm



Screw M4×8



Screw M4×14



Screw M4×22



Cross Screwdriver



Screw M3×8



Terminal Block

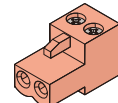

Hex Allen Key 1.5mm

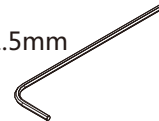

Headless Set Screw M3×5



Wrench

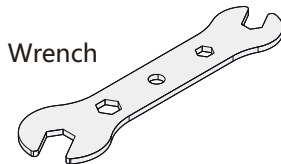

Nut M4



# Build the Robot Tank

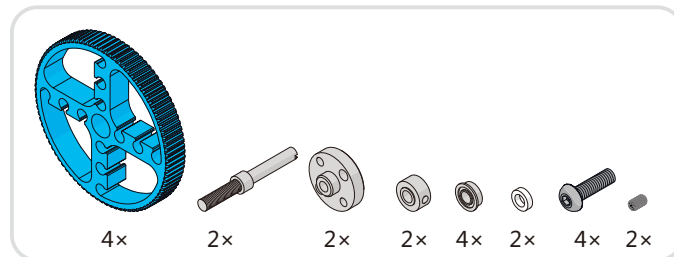
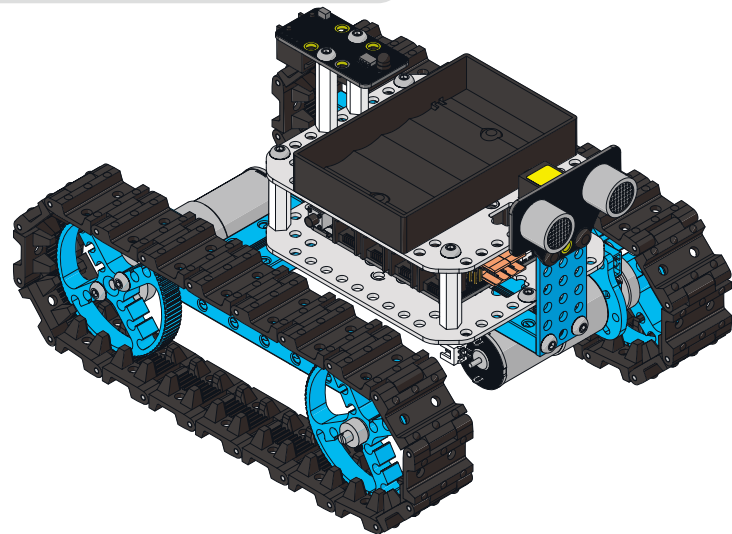
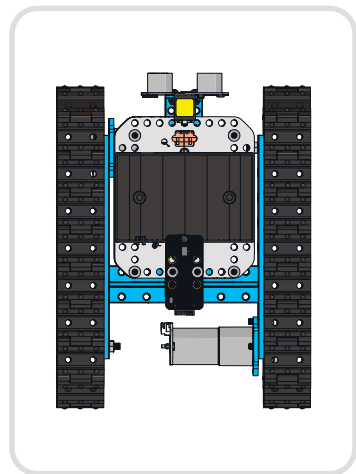
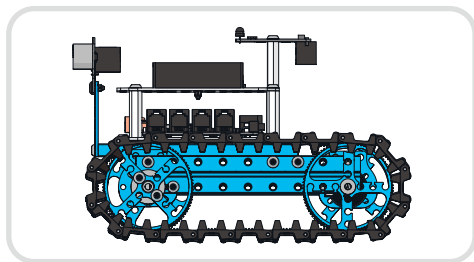
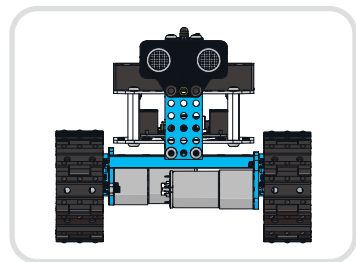

1

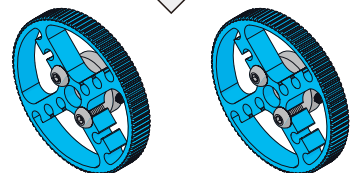
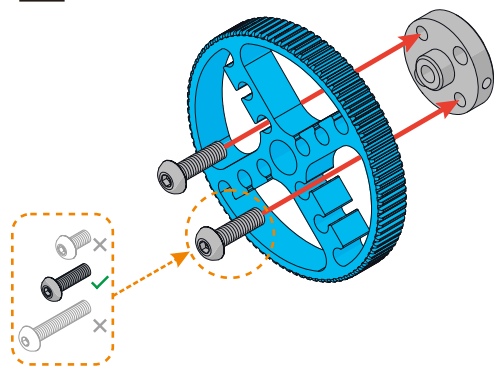

2

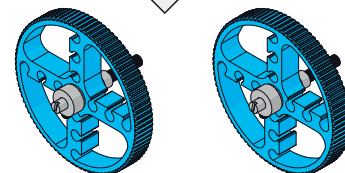
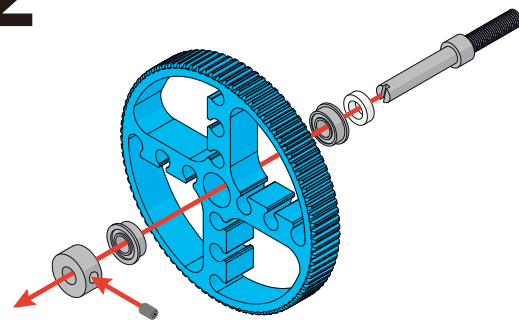

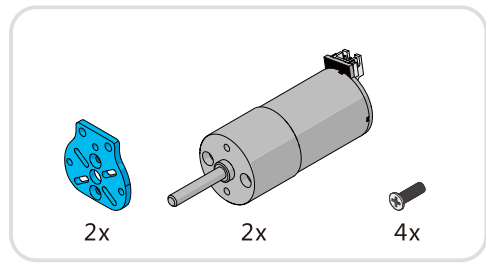

3

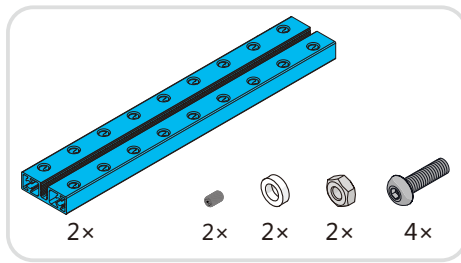
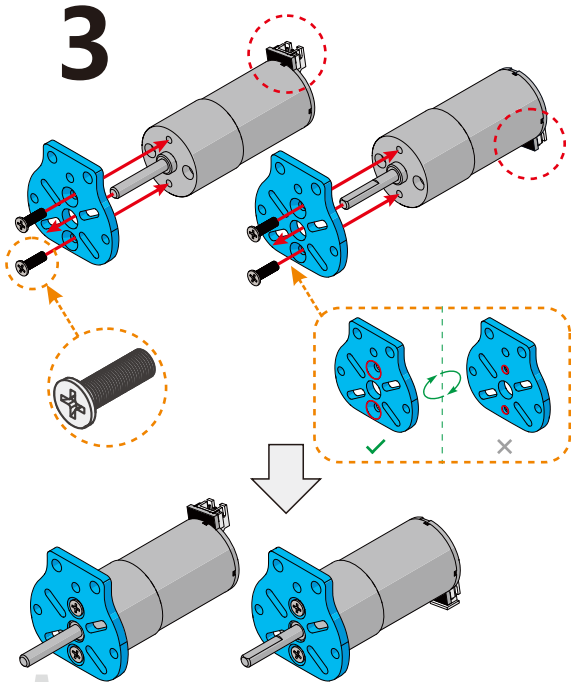

Tips: Identify the right mechanical parts from similar ones with different hole quantity included.

4

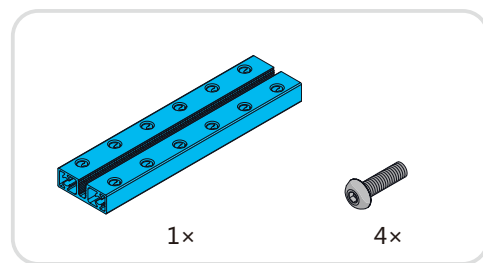
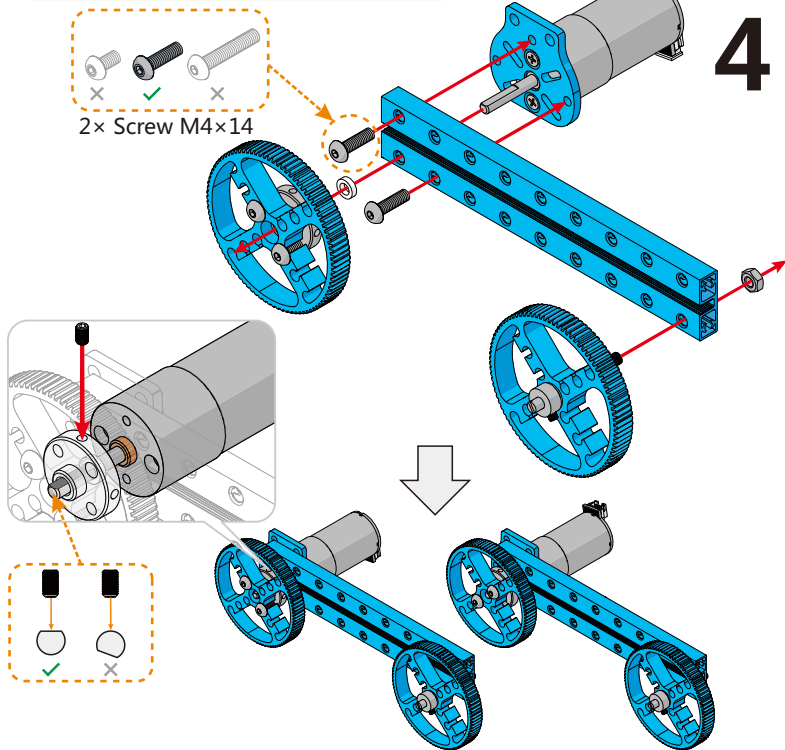

5

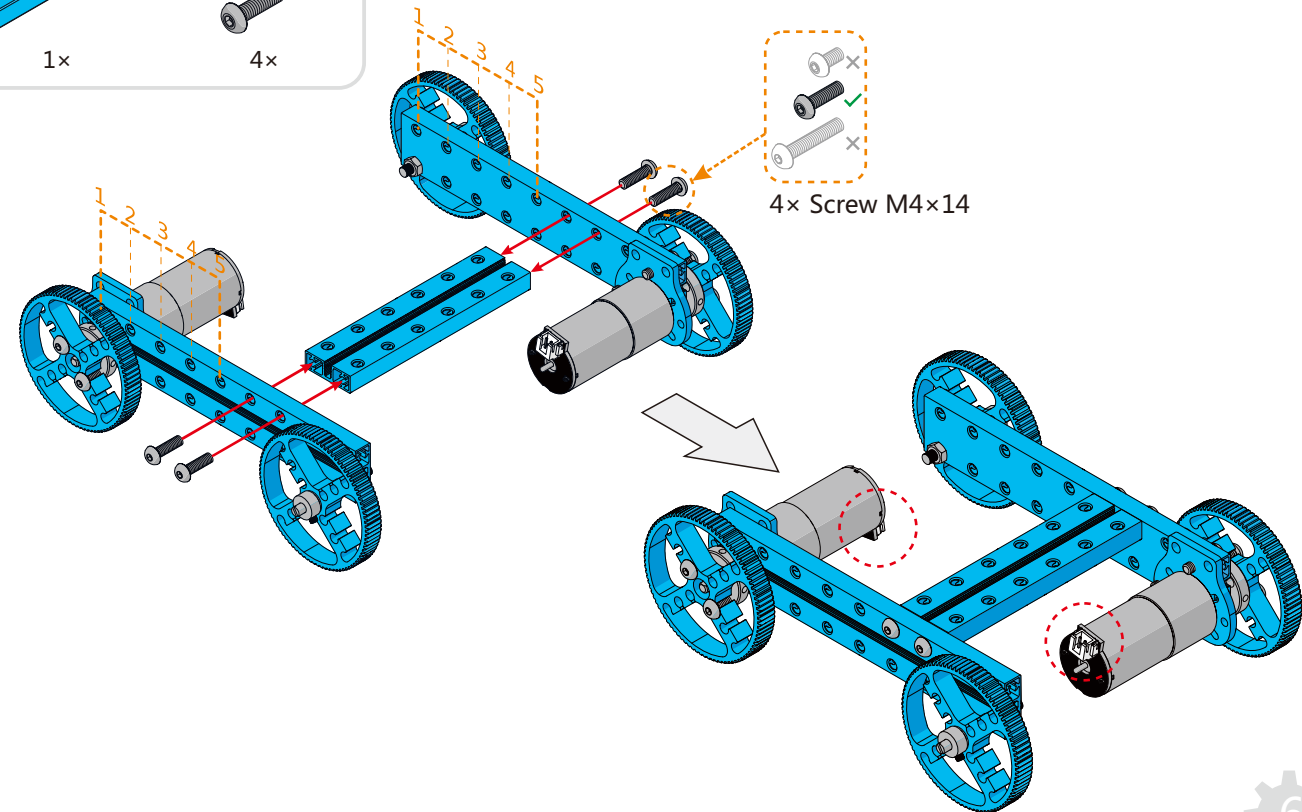

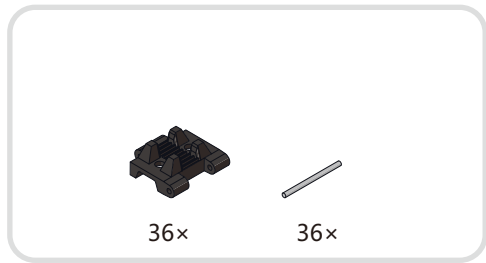

6

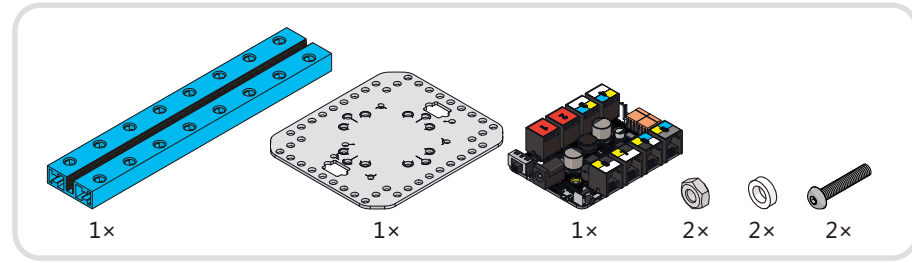
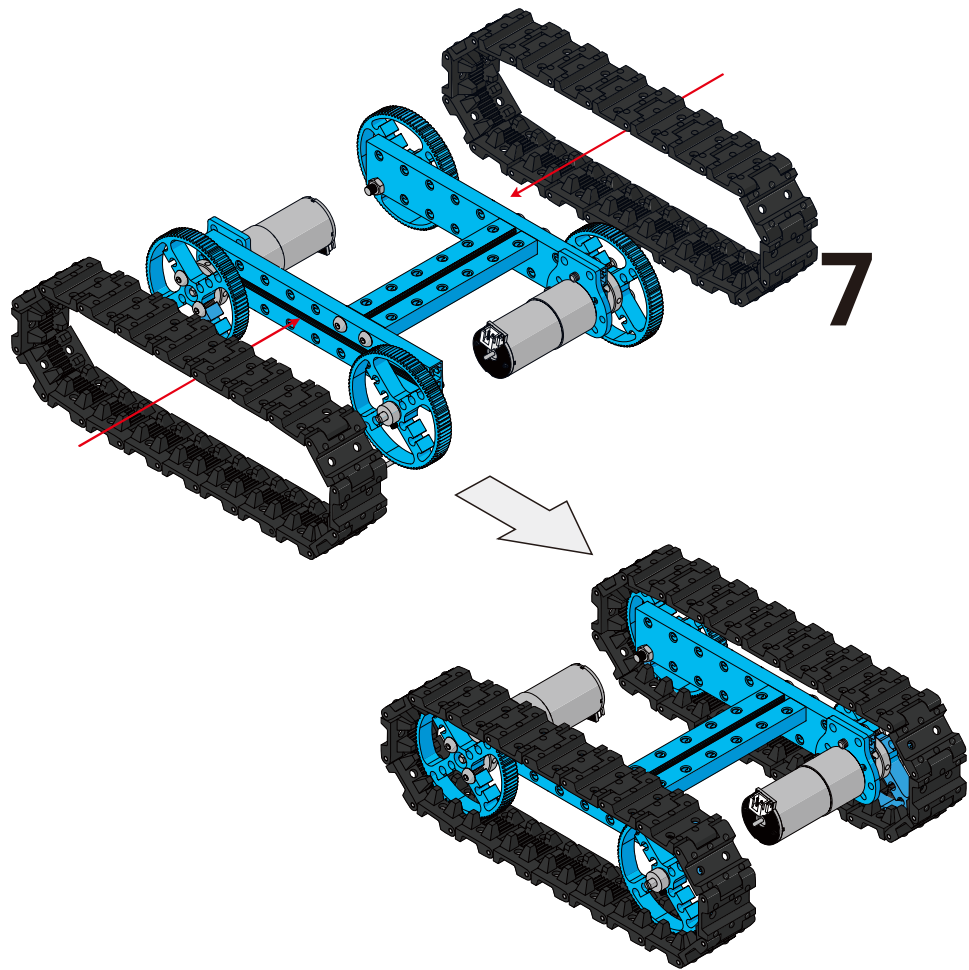
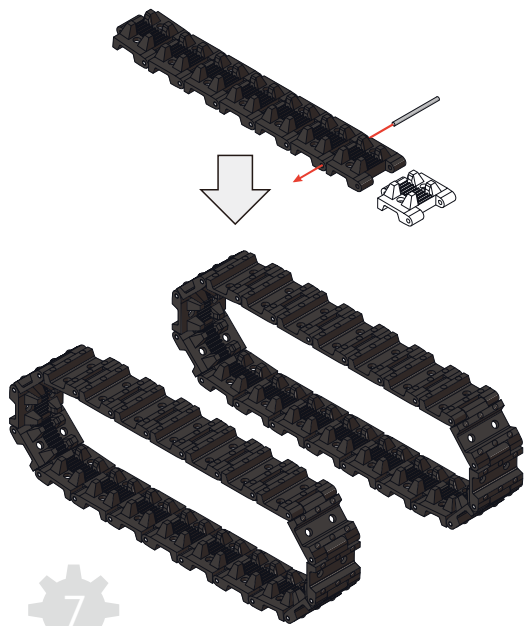

8

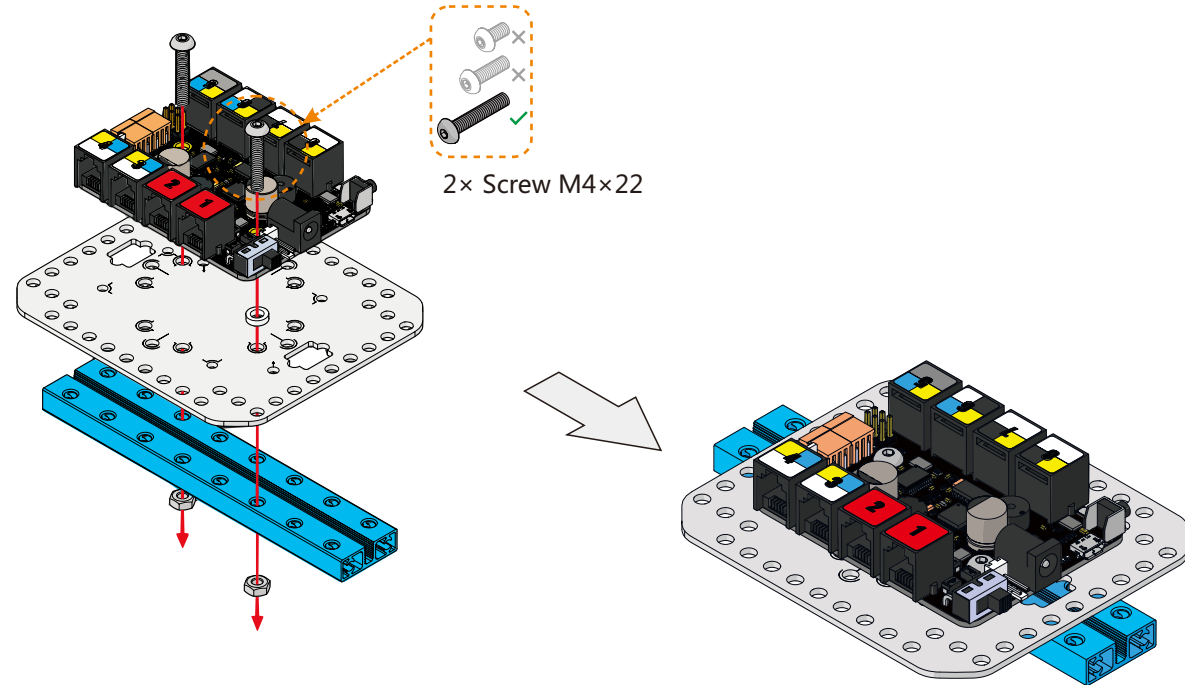

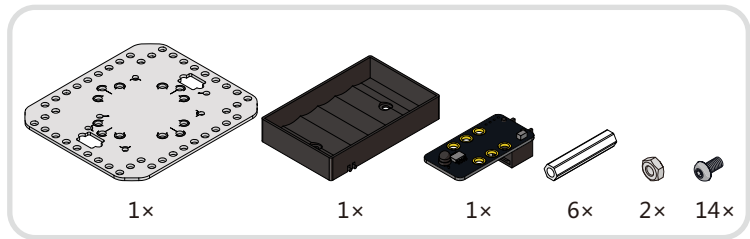

9

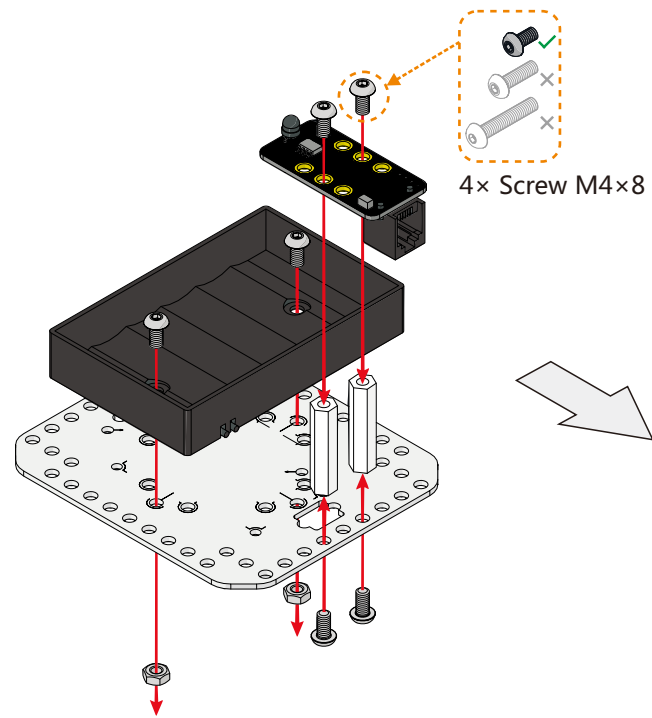

10

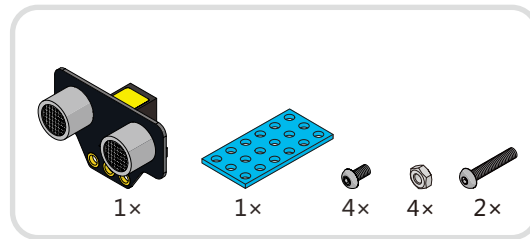
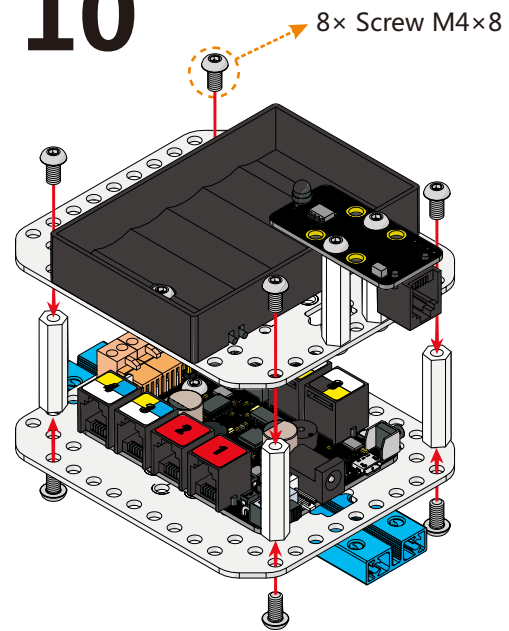

11

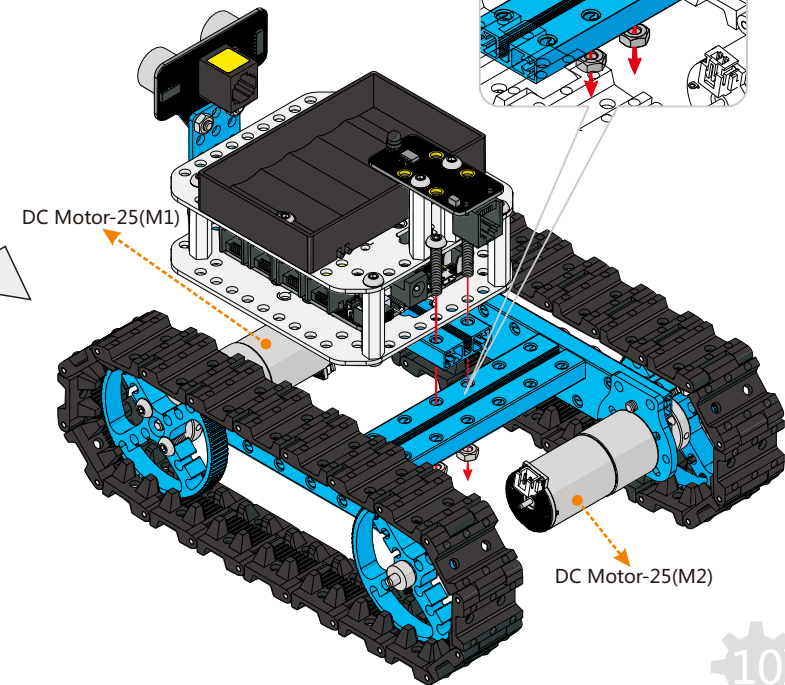
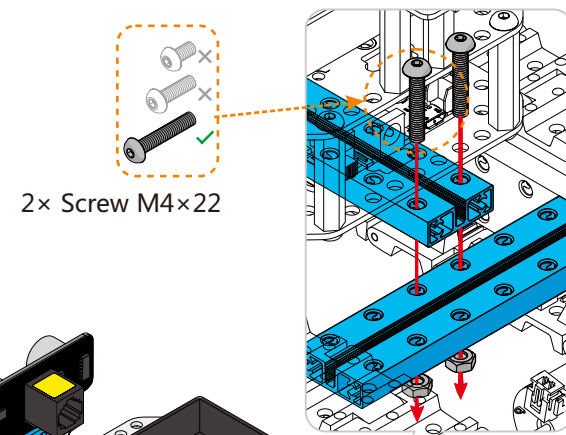
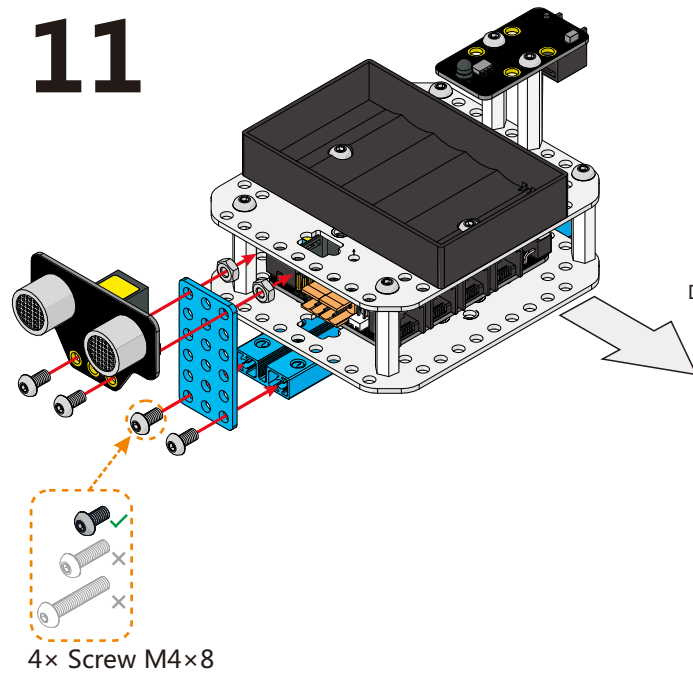



# Wiring

Me IR Remote Control(CR2025 battery,**not included**)

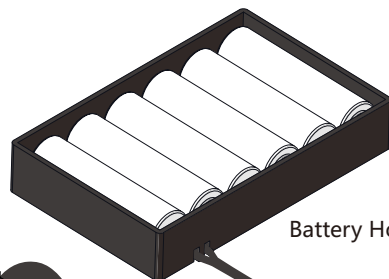
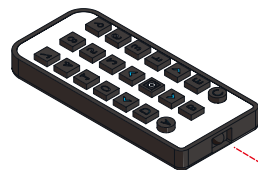

Battery Holder( 6 x AA batteries , **not included** )

Me Infrared Receiver Sensor

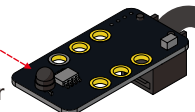

To reduce the electromagnetic interference, please add ferrite ring for the wires which connected to motors.

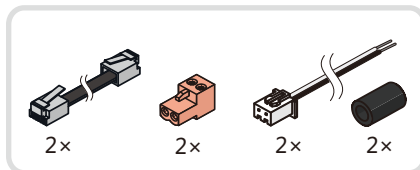

2x

2x

2x

2x

Makeblock Orion

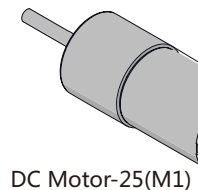
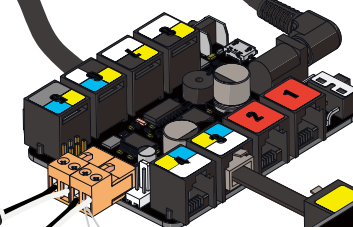

DC Motor-25(M1)

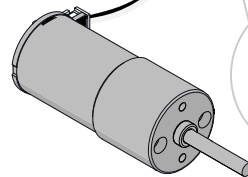

DC Motor-25(M2)



You may need to switch the order of two wires to correct the rotation direction.



# Working with remote control

—Construct It Once, Control It Everywhere

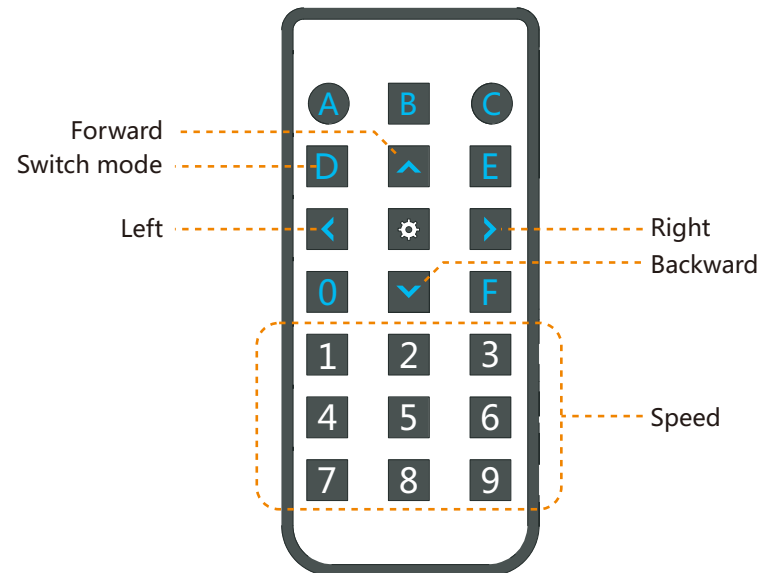

**Remote control :**  
Press key D to switch modes

**Manual mode :**  
Press direction keys for car direction and number keys for speed.

**Ultrasonic obstacle avoidance mode:**  
The car will run and avoid obstacle automatically. No response when press any keys until you switch mode.

Now it's time to play your robot!

# Build three-wheeled Robot Car

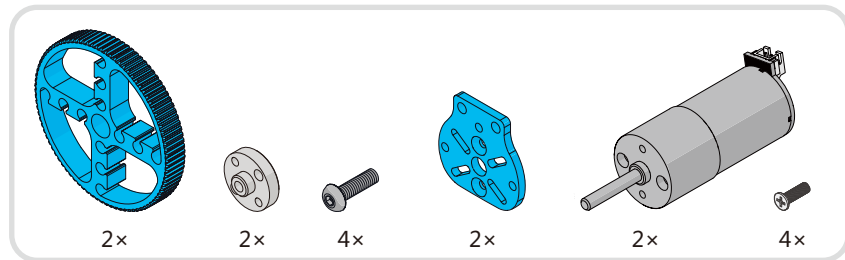
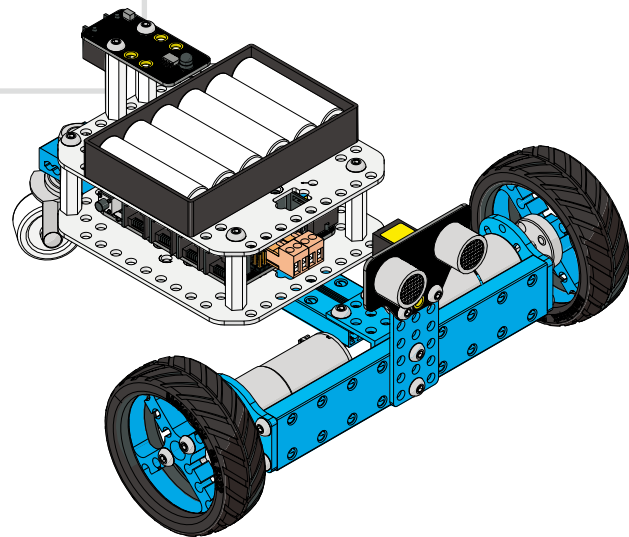
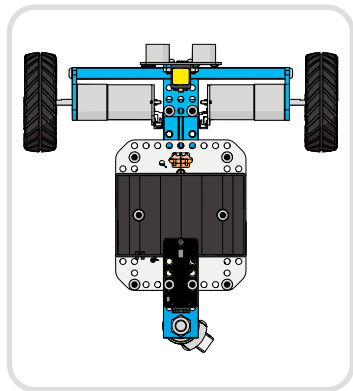
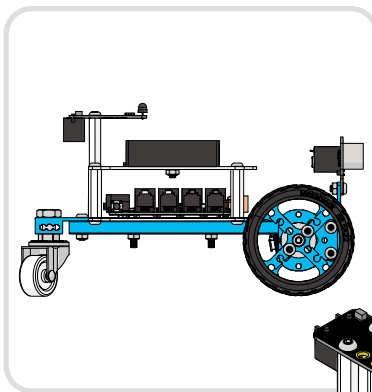
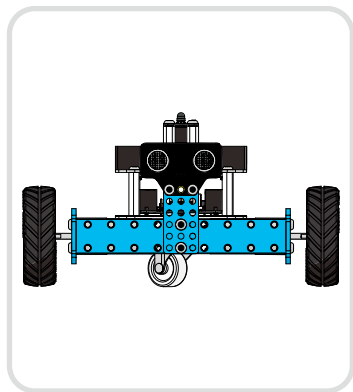

1

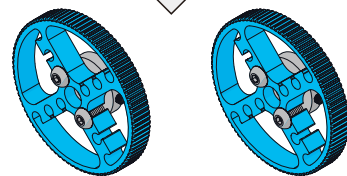
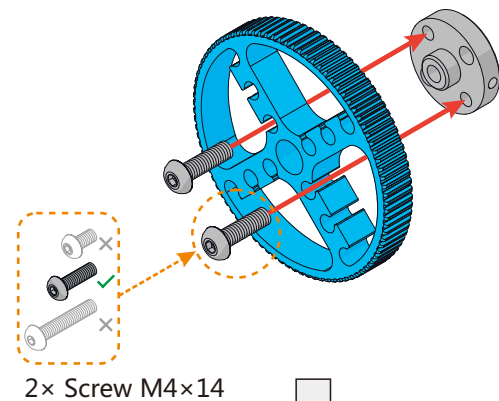

2

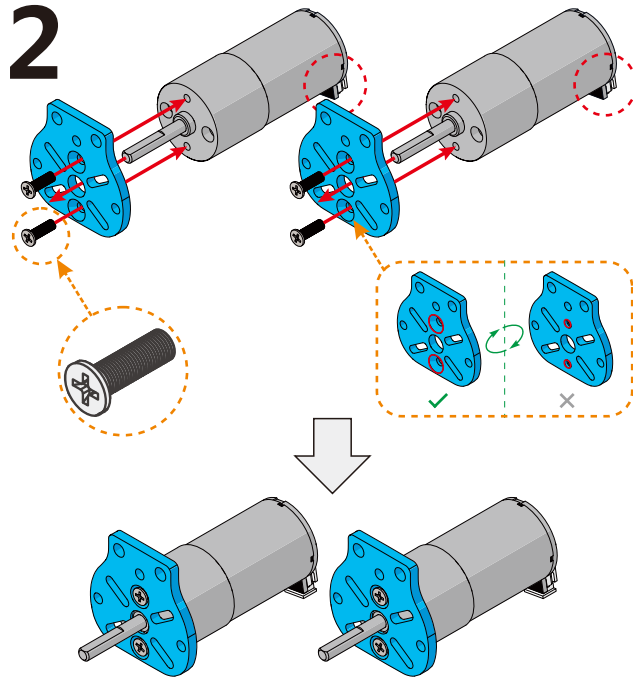

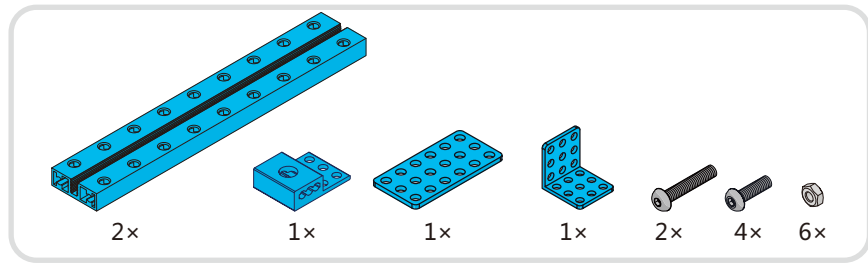

3

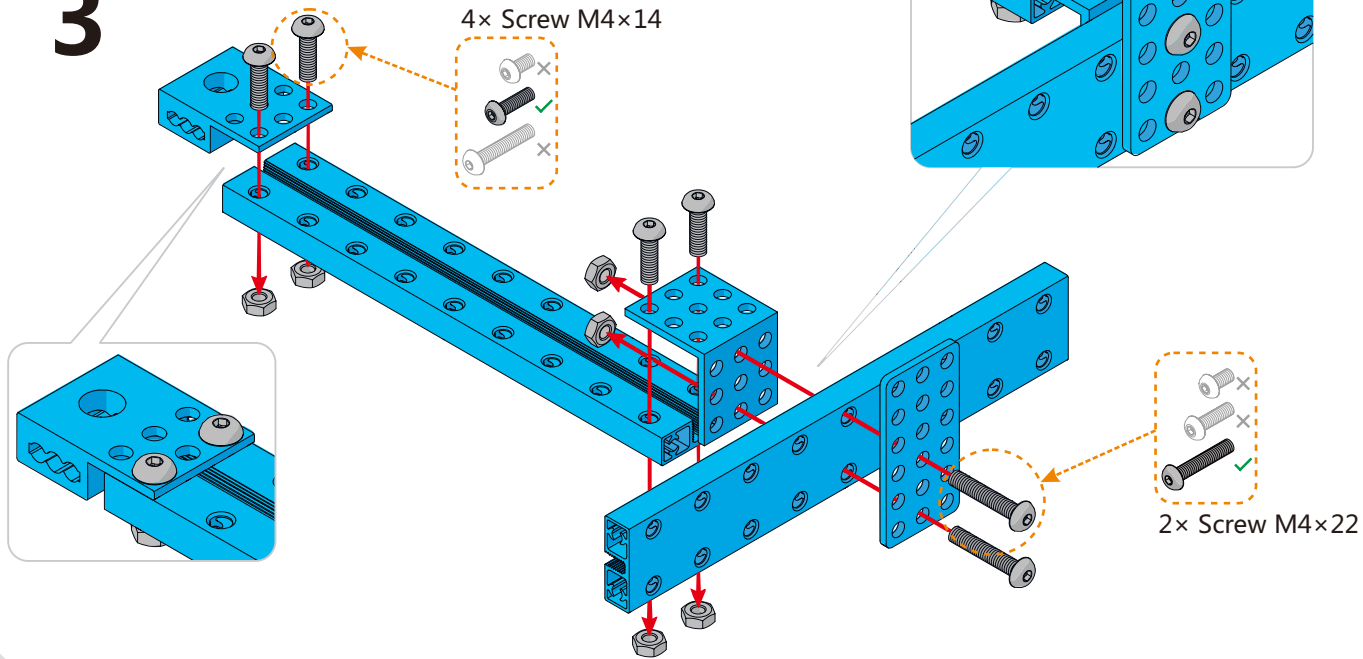

4

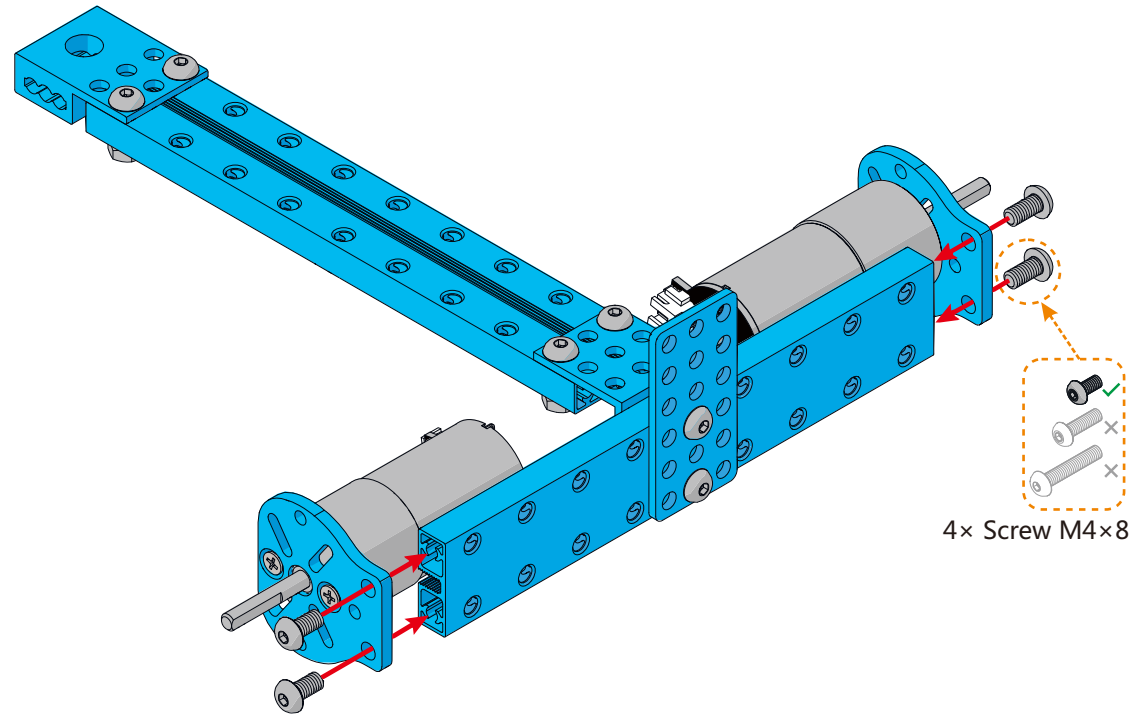

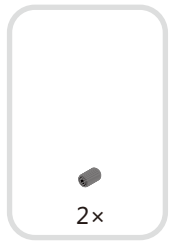

5

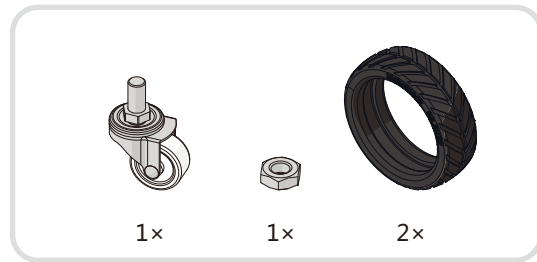
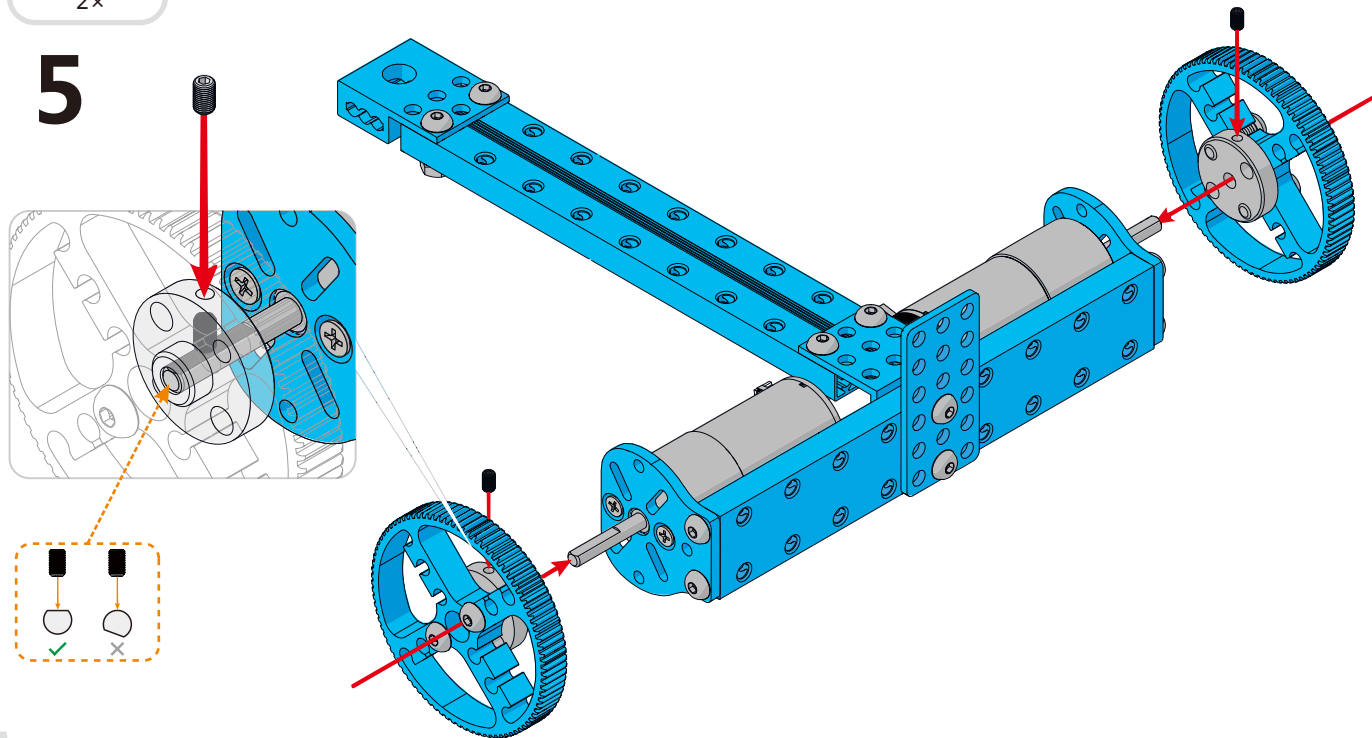

6

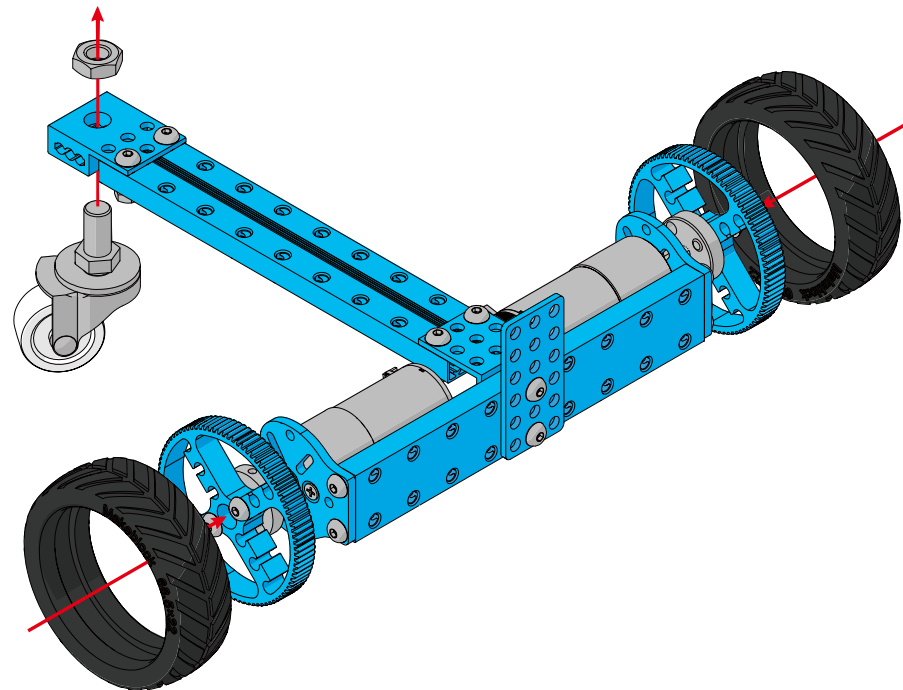

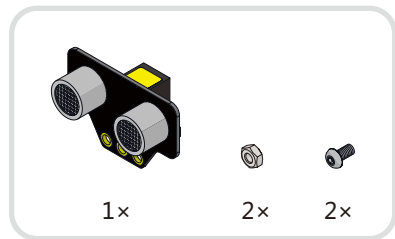

7

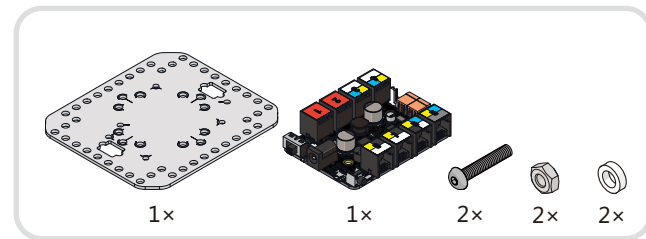
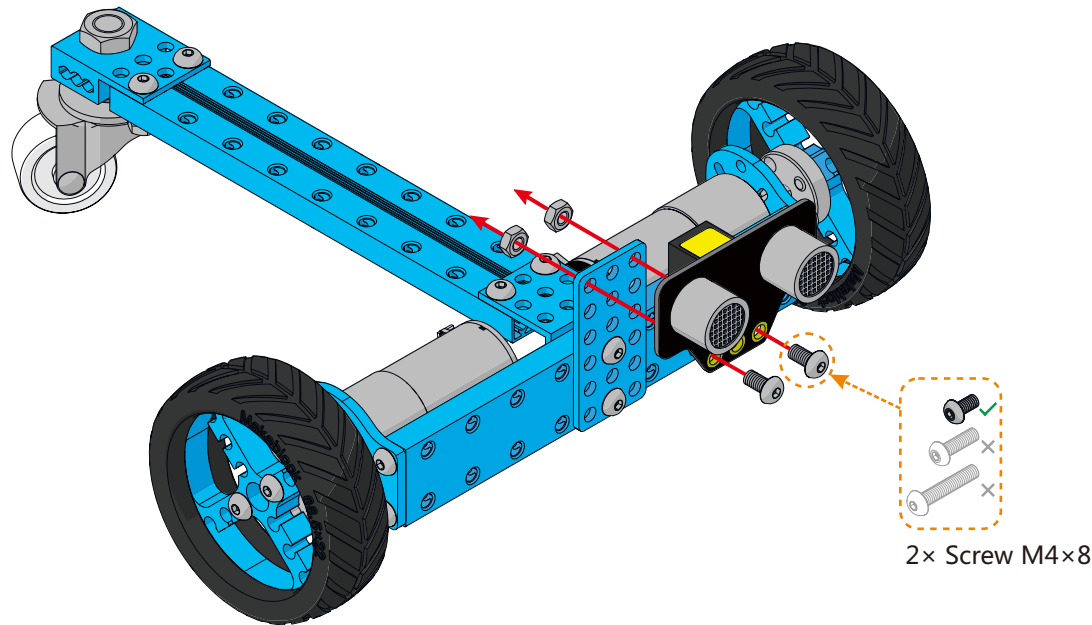

8

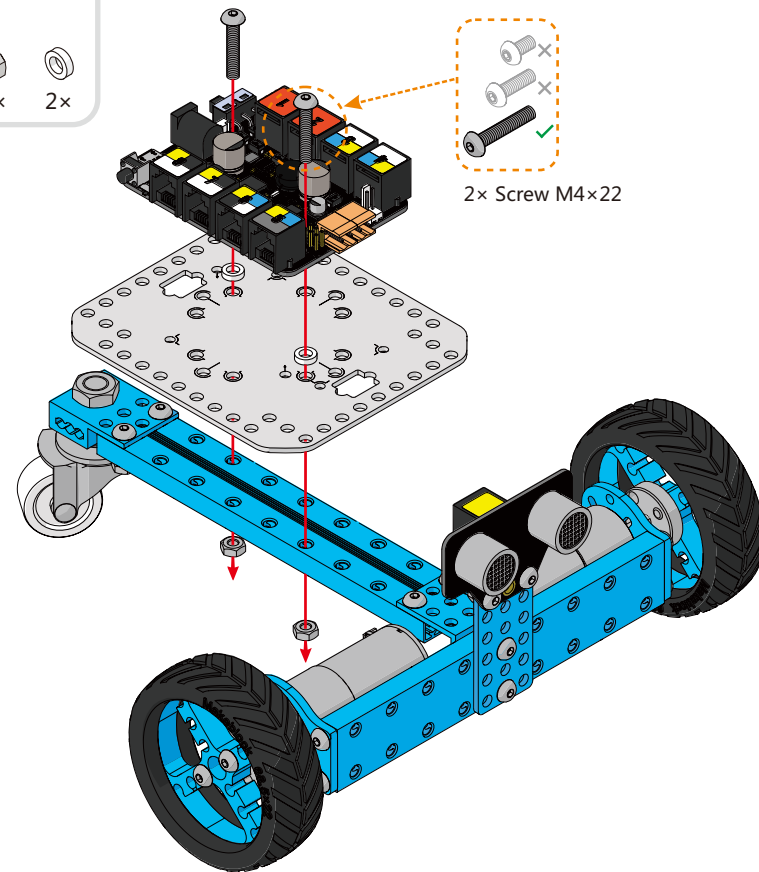

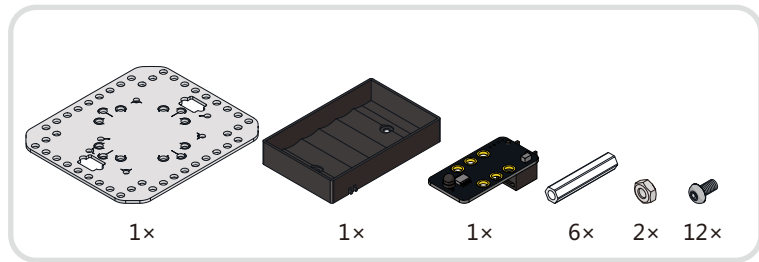

Please follow page 11 for wiring and remote control.

9

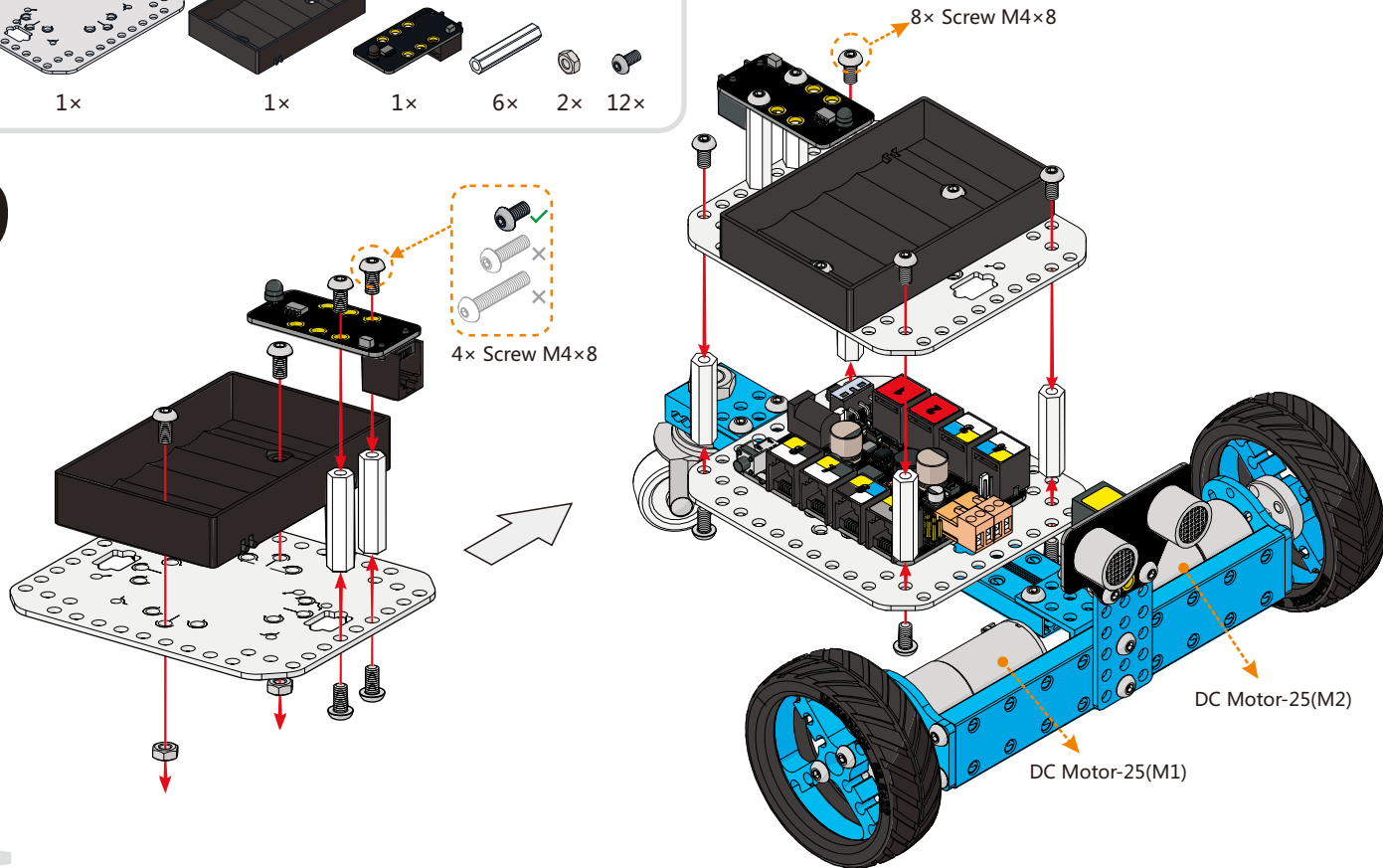

# Programming--Further exploration

## Working with mBlock--Hack the Physical World

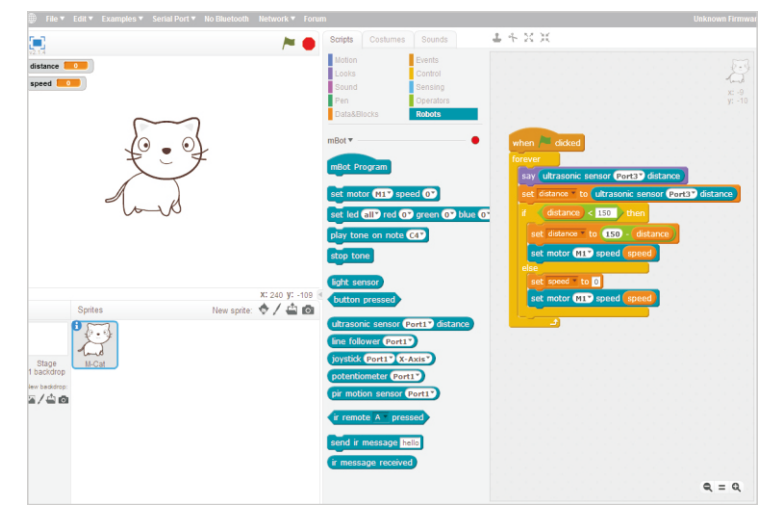

The Starter Robot Kit support mBlock perfectly which allow you re-programming your robot by simply drag and joint the blocks of mBlock. No more difficult coding.

mBlock is a free modified version of Scratch 2.0 developed by MIT Media Lab, mBlock add some hardware-related blocks in the original Scratch, with these blocks, users can read sensors, control motors and even a whole robot.

Besides blocks for the basic microcontroller functionalities, analog and digital writes and reads, PWM outputs. There are also blocks for each specific electronic modules, such as ultrasonic sensor, temperature sensor, light sensor, DC motor driver, stepper driver, etc. With these blocks, it's simple to interact with many kinds of electronic modules.







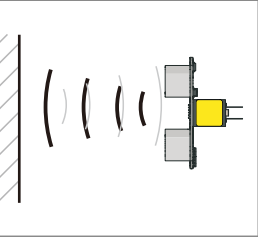
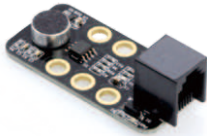
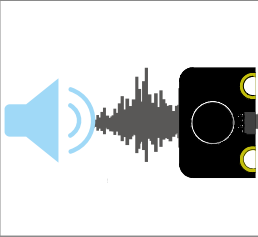

Visit the following URL for more details:  
<http://learn.makeblock.cc/learning-scratch>

## Working with Arduino IDE --Learn Programming the Fun Way

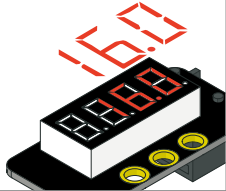
Arduino is an open-source electronics prototyping platform based on flexible , easy-to-use hardware and software.The Arduino software consists of a development environment (IDE) and the core libraries. The IDE is written in Java and based on the Processing development environment.

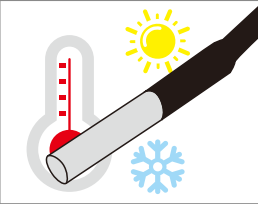
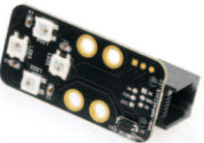
Visit the following URL for more details: <http://learn.makeblock.cc/learning-Arduino>  
 Download the library zip package: <https://github.com/Makeblock-official/Makeblock-Library/archive/master.zip>

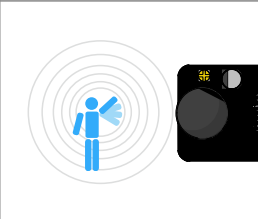
## Electronic modules on makeblock--Further exploration

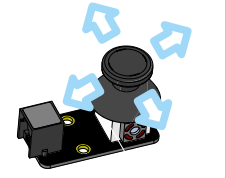
	<p><b>Ultrasonic module</b> works for measuring distance from 3cm to 400cm.</p>			<p><b>Me Sound Sensor</b> can measure the volume. It can be used in some sound interactive projects, such as a voice operated switch.</p>	
	<p><b>Me 7-Segment Display</b> is a display module with four digit tube which can show some data, such as speed, time, score etc.</p>			<p><b>Me Temperature Sensor</b> is a stainless steel tube sensor which is used for measuring temperature.</p>	
	<p><b>Me RGB LED</b> module contains four programmable RGB LEDs. Color of each LED can be set by editing components of red, green, and blue.</p>			<p><b>Me PIR Motion Sensor</b> can detect infrared ray which derives from animals/humans in less than 6 meters.</p>	
	<p><b>Me Joystick</b> is normally used to control the move direction of object.</p>		<p>see more on makeblock platform</p>		

## Kits on Makeblock--Further exploration

Add-on Pack for Starter Kit

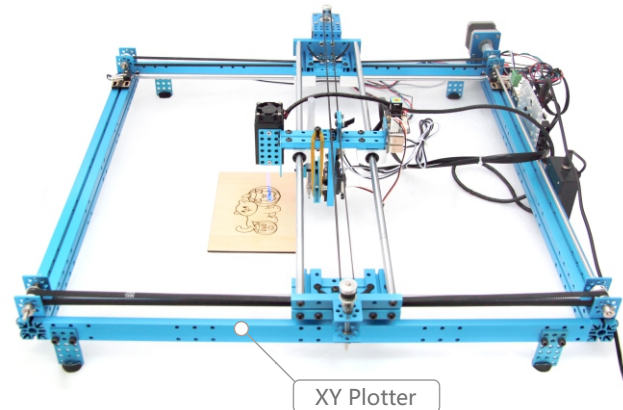
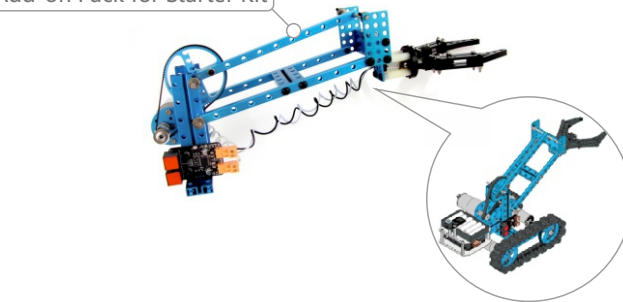

XY Plotter

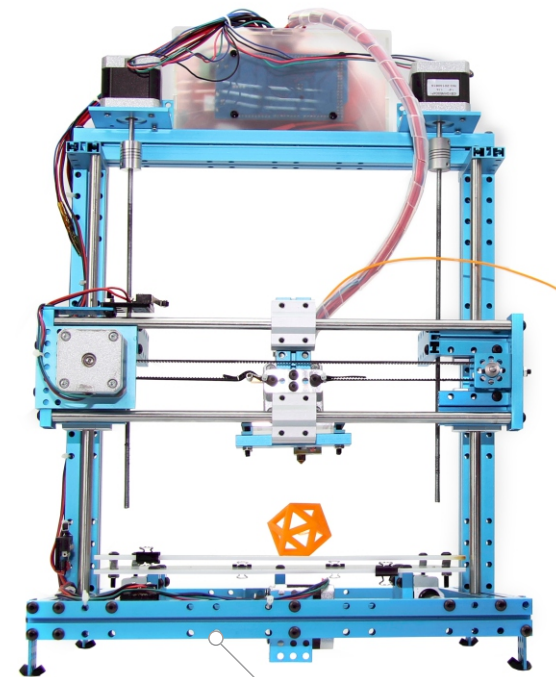

3D Printer