



Chipsmall Limited consists of a professional team with an average of over 10 year of expertise in the distribution of electronic components. Based in Hongkong, we have already established firm and mutual-benefit business relationships with customers from,Europe,America and south Asia,supplying obsolete and hard-to-find components to meet their specific needs.

With the principle of “Quality Parts,Customers Priority,Honest Operation,and Considerate Service”,our business mainly focus on the distribution of electronic components. Line cards we deal with include Microchip,ALPS,ROHM,Xilinx,Pulse,ON,Everlight and Freescale. Main products comprise IC,Modules,Potentiometer,IC Socket,Relay,Connector.Our parts cover such applications as commercial,industrial, and automotives areas.

We are looking forward to setting up business relationship with you and hope to provide you with the best service and solution. Let us make a better world for our industry!



Contact us

Tel: +86-755-8981 8866 Fax: +86-755-8427 6832

Email & Skype: info@chipsmall.com Web: www.chipsmall.com

Address: A1208, Overseas Decoration Building, #122 Zhenhua RD., Futian, Shenzhen, China



BATTERY "FUEL" GAGE



CURTIS

MODEL 900R

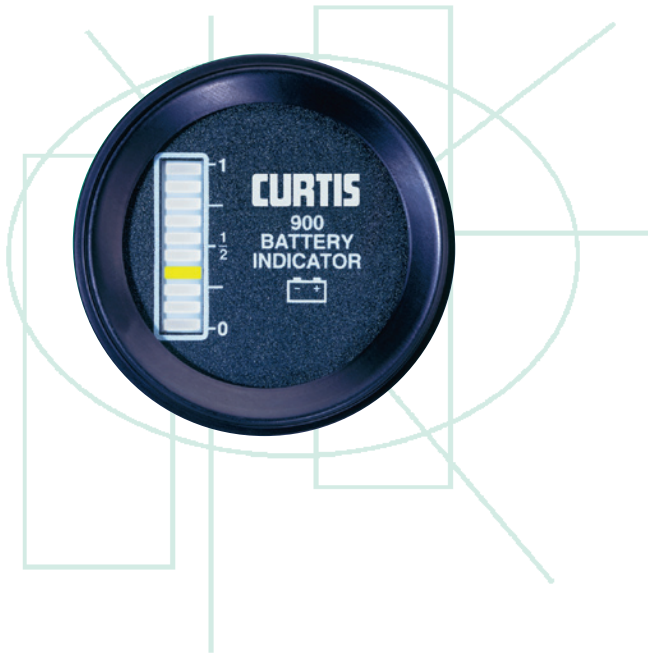

DESCRIPTION

The Curtis Model 900R battery "fuel" gauge is inexpensive and easy to install. It is a single piece package and installs via a simple 2 wire connection.

APPLICATION

Model 900R is ideally suited for lead acid battery-powered vehicles that require a display of state-of-charge only. The H reset profile is recommended for industrial/recreational vehicles that remain connected to their batteries during the charge cycle. The B reset profile is recommended for electric fork lift trucks and electric vehicles that can be disconnected from or remain connected to their batteries during the charge cycle. Units so configured have an undefeatable memory that holds the state of charge of the battery when disconnected.

FEATURES

- Multicolored 10-bar (5 green, 3 yellow, 2 red) LED displays state of charge.
- The top LED illuminates only when the battery is properly charged.
- Double flashing red LEDs signal "empty" alarm at 80% discharge.
- Recognizes improperly charged battery.
- Both fixed and adjustable discharge profiles are available.
- Easy to install.

SYSTEM VOLTAGES

- Available in single voltages from 12, 24, 36, 48, 72 and 80 VDC.

SPECIFICATIONS

- Operating Temperature:
-40 to +80° C
- Humidity:
95% RH (non-condensing) at 38° C
- Storage temperature:
-50 to +90° C
- Vibration:
Meets SAE J1378
- Shock & Vibration:
Meets SAE J1378

MODEL 900R

DIMENSIONS mm

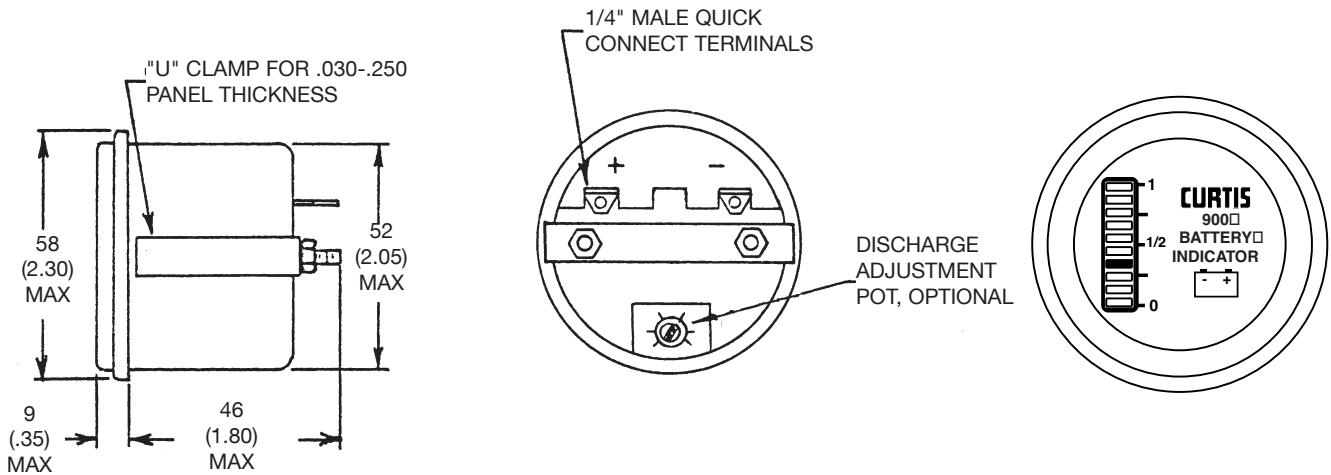

INSTALLATION

CURTIS 900R "Fuel" Gauge positive (+) terminal to battery positive (+) bus; gauge negative (-) terminal to battery negative (-) bus.

MODEL ENCODEMENT

900R	B	24	B	N	A	A	O
	Bezel B=Black No B=Stainless	VOLTAGE 12, 24, 36, 48 72, 80 VDC	MEMORY/RESET LEVEL B - with memory, HVR* & OCR** H - no memory, HVR* only	DISCHARGE PROFILE Full (v/c) Empty (v/c) G = 1.97 1.75 N = 2.04 1.73 W = 2.02 1.85 A = Adjustable; range of 1.56 to 1.82 v/c at empty B = Light duty adjustable; range of 1.71 to 1.93 v/c at empty	OPTION A = no option	OPTION A = no option	OEM CODE O = CURTIS logo

- * HVR: High Voltage Reset – Battery is connected to gauge while recharging. The gauge resets to Full when the battery is above the HVR level for 6 minutes. With B or H, HVR = 2.35v/c.
- **OCR: Open Circuit Reset – 2.09 v/c – Only available on units with Memory – Battery is disconnected from gauge while recharging. The gauge will reset to Full if the reconnected battery is above the OCR level. The gauge will display its stored state-of-charge if the battery is below this level. With B,, OCR = 2.09 v/c.

WARRANTY Two year limited warranty from time of delivery.

