



Chipsmall Limited consists of a professional team with an average of over 10 year of expertise in the distribution of electronic components. Based in Hongkong, we have already established firm and mutual-benefit business relationships with customers from,Europe,America and south Asia,supplying obsolete and hard-to-find components to meet their specific needs.

With the principle of “Quality Parts,Customers Priority,Honest Operation,and Considerate Service”,our business mainly focus on the distribution of electronic components. Line cards we deal with include Microchip,ALPS,ROHM,Xilinx,Pulse,ON,Everlight and Freescale. Main products comprise IC,Modules,Potentiometer,IC Socket,Relay,Connector.Our parts cover such applications as commercial,industrial, and automotives areas.

We are looking forward to setting up business relationship with you and hope to provide you with the best service and solution. Let us make a better world for our industry!



Contact us

Tel: +86-755-8981 8866 Fax: +86-755-8427 6832

Email & Skype: info@chipsmall.com Web: www.chipsmall.com

Address: A1208, Overseas Decoration Building, #122 Zhenhua RD., Futian, Shenzhen, China



NOTES:

1. MATERIALS AND FINISHES:
 BODY, COUPLING NUT, CAP, RETAINING RING-STAINLESS STEEL, PASSIVATED
 CONTACT-BERYLLIUM COPPER, GOLD PLATING
 INSULATOR- PTFE
 GASKET-SILICONE

2. ELECTRICAL:

- A. IMPEDANCE: 50 OHMS
- B. FREQUENCY RANGE: DC-12 GHz
- C. DIELECTRIC WITHSTANDING VOLTAGE: 750 VRMS, MIN,

3. MECHANICAL

- A. DURABILITY: 500 CYCLES MIN.
- B. TEMPERATURE RANGE: -65°C TO +165°C
- C. COUPLING NUT MUST BE FREE TURNING AND MUST BE CAPABLE OF WITHSTANDING A PULL-OFF FORCE 100 LBS AND A COUPLING PROOF TORQUE OF 15 IN-LBS

4. PACKAGING

- A. QUANTITY: SINGLE PACK
- B. MARKING: BAG TO BE MARKED
- C. "AMPHENOL, 901-9219-ASF AND DATE CODE"

901-9219-ASF		REVISIONS			
DRAWING NO.	REV	DESCRIPTION	DATE	ECO	APPR
THIRD ANGLE PROJ.	--	RELEASE TO MFG.	-----	-----	-----
	L	REDRAWN IN PRO-E, ADDED COD	1/14/13	48616	HR
	M	ADD STAMP TO COD	3/6/13	49452	CPM
	N	SEE SHEET 1	8/28/13	49727	RV

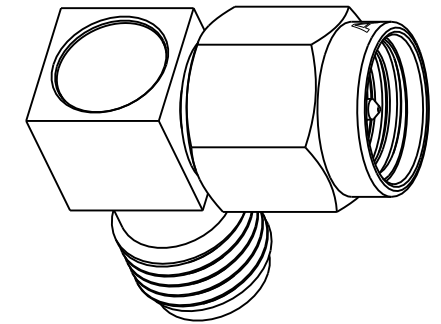
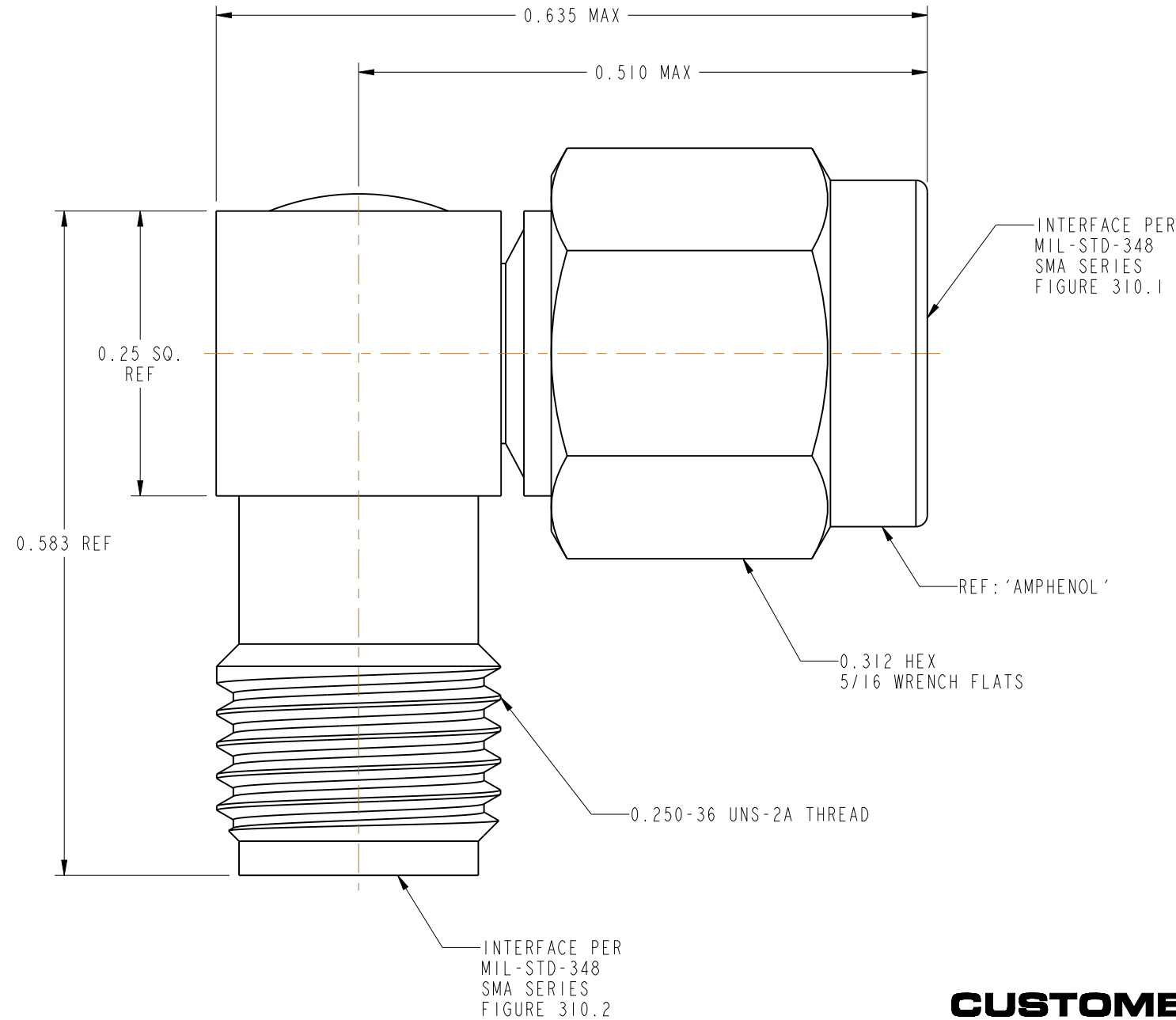

CUSTOMER OUTLINE DRAWING

ALL OTHER SHEETS ARE FOR INTERNAL USE ONLY

UNLESS OTHERWISE SPECIFIED, DIMENSIONS ARE IN INCHES AND TOLERANCES ARE: 2 PLACE DECIMAL ±.015 (0,381 mm) 3 PLACE DECIMAL ±.005 (0,127 mm) ANGLES ± 1°	MATERIAL	DRAWN HARI R	DATE 01-Jun-11	TITLE SMA ADAPTER RIGHT ANGLE PLUG-JACK	Amphenol Amphenol Corporation Communication and Network Products Division Danbury, CT U.S.A. 06810
	REFERENCE DOR 42-901-315877 SIMILAR TO 901-125-11SF	ENGINEER HARI R	DATE 01-Jun-11		
NOTICE - These drawings, specifications, or other data (1) are, and remain the property of Amphenol Corp. (2) must be returned upon request; and (3) are confidential and not to be disclosed to any person other than those to whom they are given by Amphenol Corp. The furnishing of these drawings, specifications, or other data by Amphenol Corp., or to any other person to anyone for any purpose is not to be regarded by implication or otherwise in any manner licensing, granting rights or permitting such holder or any other person to manufacture, use or sell any product, process or design, patented or otherwise, that may in any way be related to or disclosed by said drawings, specifications, or other data.		APPROVED K. CAPOZZI	DATE 1/14/13		SCALE: 3.0:1
		CAD FILE			CODE ID 74868
				DRAWING NO. 901-9219-ASF	SHEET 2 OF 2
					REV N