



Chipsmall Limited consists of a professional team with an average of over 10 year of expertise in the distribution of electronic components. Based in Hongkong, we have already established firm and mutual-benefit business relationships with customers from,Europe,America and south Asia,supplying obsolete and hard-to-find components to meet their specific needs.

With the principle of “Quality Parts,Customers Priority,Honest Operation,and Considerate Service”,our business mainly focus on the distribution of electronic components. Line cards we deal with include Microchip,ALPS,ROHM,Xilinx,Pulse,ON,Everlight and Freescale. Main products comprise IC,Modules,Potentiometer,IC Socket,Relay,Connector.Our parts cover such applications as commercial,industrial, and automotives areas.

We are looking forward to setting up business relationship with you and hope to provide you with the best service and solution. Let us make a better world for our industry!



Contact us

Tel: +86-755-8981 8866 Fax: +86-755-8427 6832

Email & Skype: info@chipsmall.com Web: www.chipsmall.com

Address: A1208, Overseas Decoration Building, #122 Zhenhua RD., Futian, Shenzhen, China



90112-AS

PIN-IN-PASTE/FLEX PCB SPRING LOADED CONTACT

Visit us at WWW.PRECI-DIP.COM



preci-dip

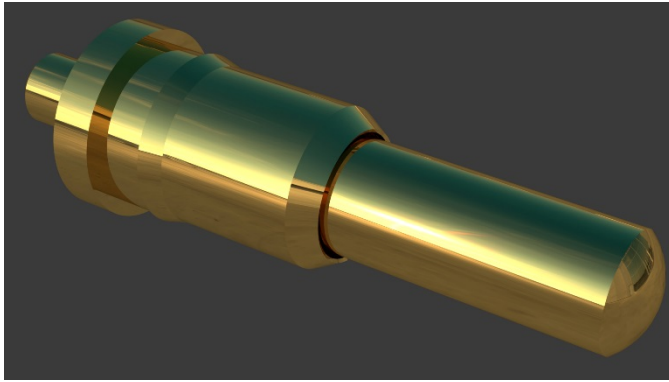

Engineered for Success

Assembly: Stub Tail

Overall Length:

6.5mm (.256")

Above Board Height:

5.5mm (.217")

Stroke: 1.4mm (.055")

ORDER AS:

90112-AS

APPLICATION NOTES:

PRODUCT DESCRIPTION:

Preci-Dip Spring Loaded contact stub-tail termination for soldering to thin PCBs, flex or pin-in-paste soldering to PCBs. Every Preci-Dip spring contact is Swiss precision machined and assembled for highest quality, performance and long product life.

PRODUCT PACKAGING:

This product is sold in bulk. It can be supplied on tape and reel. It can be supplied assembled in an insulator. Let us help you with your custom packaging request.

HOW TO USE THIS PRODUCT:

This product is ideal for PCB applications on 2.54mm (.100") grid. With solid one-piece body construction, These spring loaded contacts are typically used in docking stations, recharging stations, module stacking and pluggable SLC requirements.

CAN I CUSTOMIZE THIS PRODUCT?

Preci-Dip welcomes custom design requests. Please provide us your spring force and packaging requirements. Call today to discuss your application.

Temperature rise [°C]

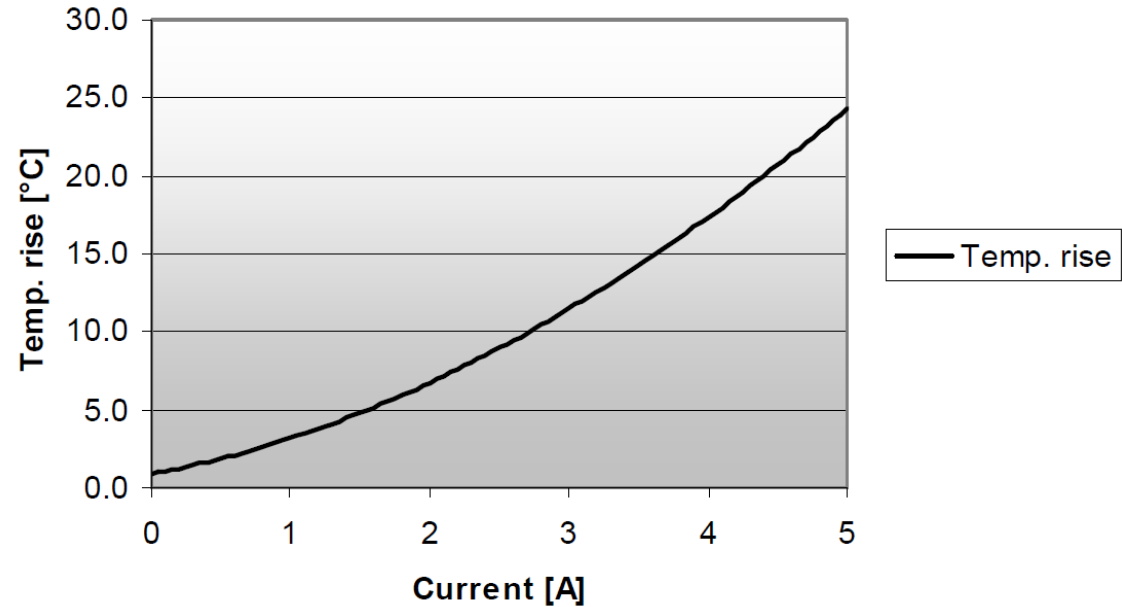

Current: 3A continuous @ 10 ° C rise

Stub tail

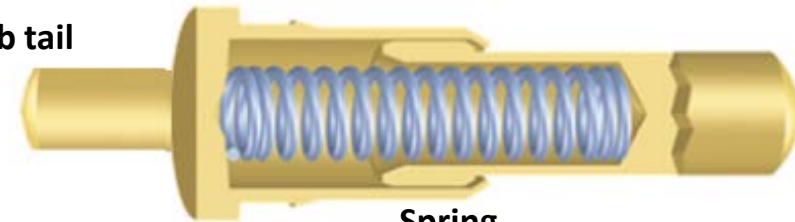

Piston

Spring

HOW IT WORKS:

Strong, secure and featuring one piece solid body construction, there are no capped components at the bottom of this spring contact. No seams for solder to wick inside the shell.



90112-AS

PIN-IN-PASTE/FLEX PCB SPRING LOADED CONTACT

Visit us at WWW.PRECI-DIP.COM



preci-dip

SPECIFICATIONS:

MATERIAL:

Piston: Brass Alloy, plated 0.5um (20μ") Gold
Barrel: Brass Alloy, plated 0.5um (20μ") Gold
Spring: Stainless Steel

Engineered for Success

ELECTRICAL:

Current: 3A continuous @ @ 10 ° C rise. 5A Peak.
Rated Voltage: 100Vrms 150Vdc
Contact Resistance: 20mΩ max..

ENVIRONMENTAL

Operating Temperature: -55 to 125° C
Passed Vibration Test Sinusoidal per IEC 512.6d / IEC 68-2-6
Passed Shock Test per IEC 512.6d / IEC 68-2-27
No electrical discontinuity greater than 1μs.

SPRING CONTACT FEATURES:

- * Swiss Experience
- * Swiss Quality
- * Swiss precision machined components
- * Seamless shell construction
- * Press-fit barb on barrel for packaging
- * Gold plating for corrosion resistance.
- * Smooth piston travel
- * High quality, smooth surface finish on tip of piston.
- * Strong and durable construction
- * RoHs

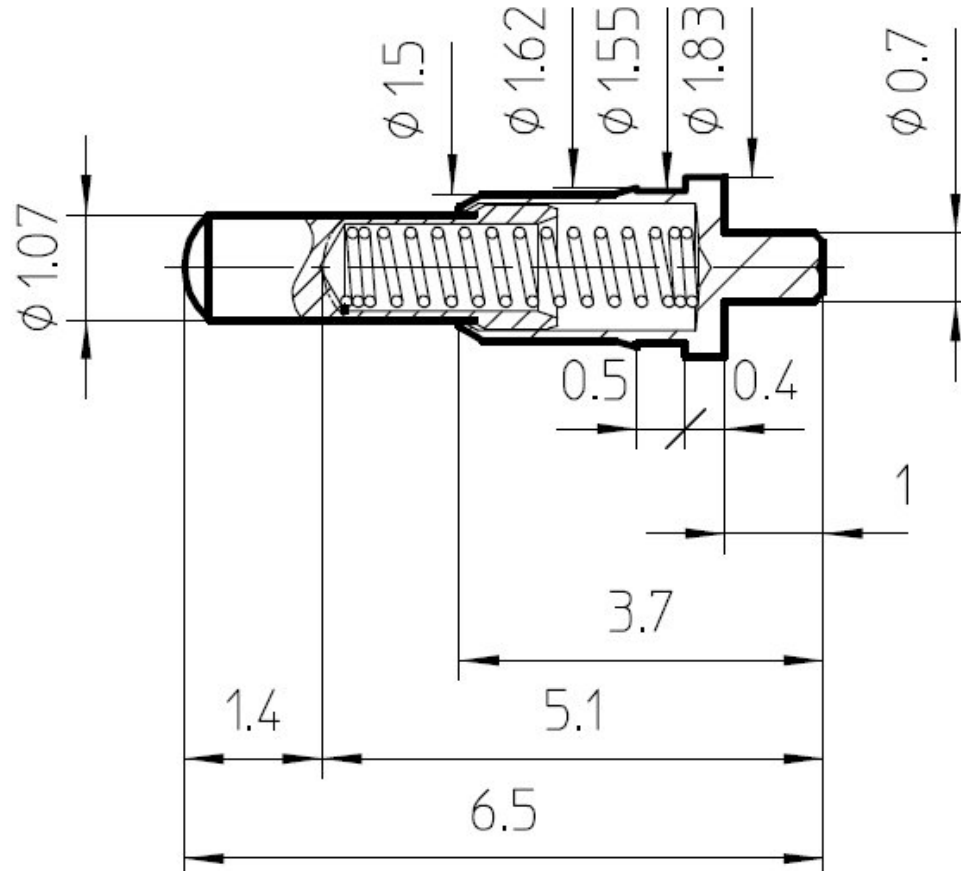

MECHANICAL

Durability: Minimum 40,000 cycles.
Stroke: 1.4mm (.055")
Working Travel: 5.5-4.15mm
(.217-.163")
Force: Initial .25N
Half-Stroke .6N

HOW TO CUSTOMIZE A SPRING CONTACT

Specify:

1. Stacking distance between boards
2. Desired piston stroke
3. Desired spring force
4. Desired current rating.
5. Termination style SMT, Solder tail, Wire
6. Desired Cycle life

This product can be assembled in SIP or STRIP, and provided on Tape and Reel. Please inquire if interested.

