



Chipsmall Limited consists of a professional team with an average of over 10 year of expertise in the distribution of electronic components. Based in Hongkong, we have already established firm and mutual-benefit business relationships with customers from,Europe,America and south Asia,supplying obsolete and hard-to-find components to meet their specific needs.

With the principle of “Quality Parts,Customers Priority,Honest Operation,and Considerate Service”,our business mainly focus on the distribution of electronic components. Line cards we deal with include Microchip,ALPS,ROHM,Xilinx,Pulse,ON,Everlight and Freescale. Main products comprise IC,Modules,Potentiometer,IC Socket,Relay,Connector.Our parts cover such applications as commercial,industrial, and automotives areas.

We are looking forward to setting up business relationship with you and hope to provide you with the best service and solution. Let us make a better world for our industry!



## Contact us

Tel: +86-755-8981 8866 Fax: +86-755-8427 6832

Email & Skype: info@chipsmall.com Web: www.chipsmall.com

Address: A1208, Overseas Decoration Building, #122 Zhenhua RD., Futian, Shenzhen, China



## INSULATED PC SPACERS/SUPPORTS

- Board will be electrically insulated, eliminates need for insulating washers
- No tool required for installation • Easy snap-in assembly

### ADHESIVE LOCK-IN RELEASE SUPPORTS

- One end attaches to chassis with self adhesive pads
- No drilling to chassis required leaving outside in perfect condition
- Other end snap into .062 (1.57) board
- Board is easily releasable for repair or upgrade

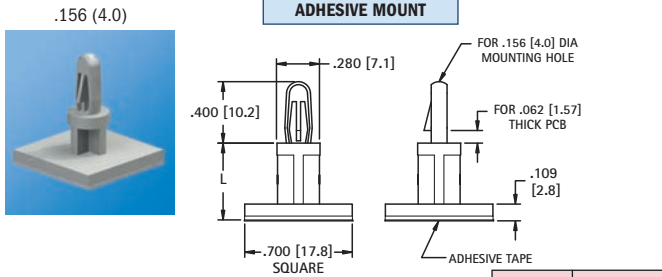

CAT. NO.	L LENGTH
9080	.187 (4.7)
9081	.250 (6.4)
9082	.375 (9.5)
9083	.500 (12.7)
9084	.625 (15.9)

**Material:** Nylon 6/6, UL Rated 94V-0

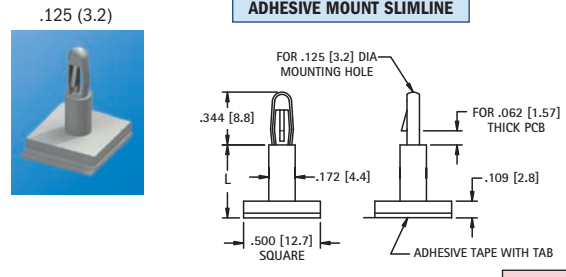

CAT. NO.	L LENGTH
9070	.187 (4.7)
9071	.250 (6.4)
9072	.375 (9.5)
9073	.500 (12.7)
9074	.625 (15.9)

**Material:** Nylon 6/6, UL Rated 94V-0

### PC SPACER SUPPORTS

- One end locks into chassis • Other end supports the PC Board
- Ideal for mid supports of large boards
- Simplifies assembly for multiple support applications • Reduces the amount of holes required in PC board

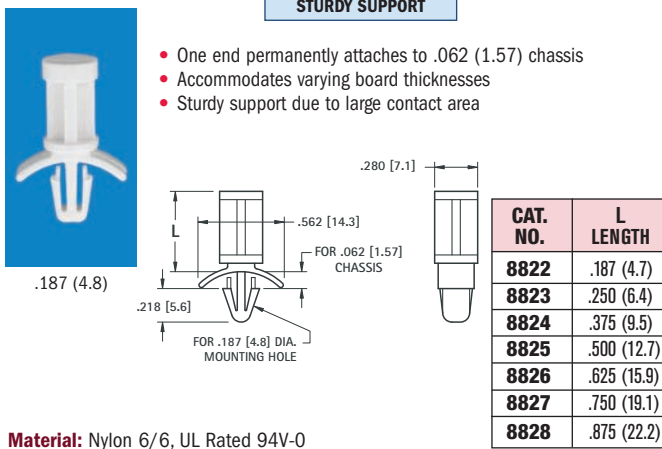

CAT. NO.	L LENGTH
8823	.187 (4.7)
8823	.250 (6.4)
8824	.375 (9.5)
8825	.500 (12.7)
8826	.625 (15.9)
8827	.750 (19.1)
8828	.875 (22.2)

**Material:** Nylon 6/6, UL Rated 94V-0

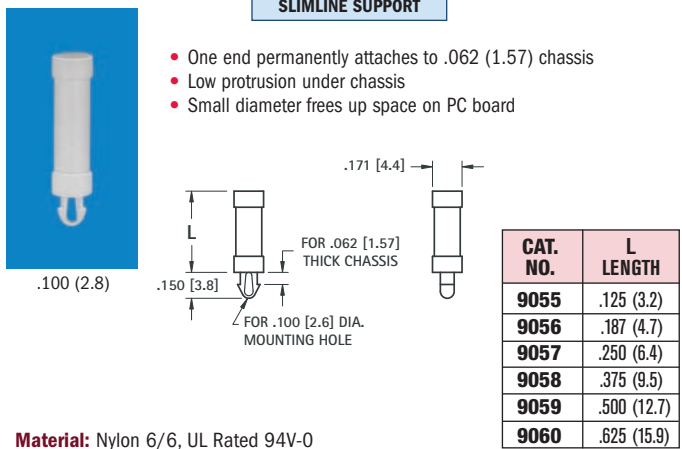

CAT. NO.	L LENGTH
9055	.125 (3.2)
9056	.187 (4.7)
9057	.250 (6.4)
9058	.375 (9.5)
9059	.500 (12.7)
9060	.625 (15.9)

**Material:** Nylon 6/6, UL Rated 94V-0

### REVERSE CHASSIS MOUNT SUPPORTS

- Permanently attaches to .059 (1.51) - .065 (1.65) thick case from outside
- Provides flat clean cosmetic appearance • Ideal for low clearance applications or for mounting directly to case walls

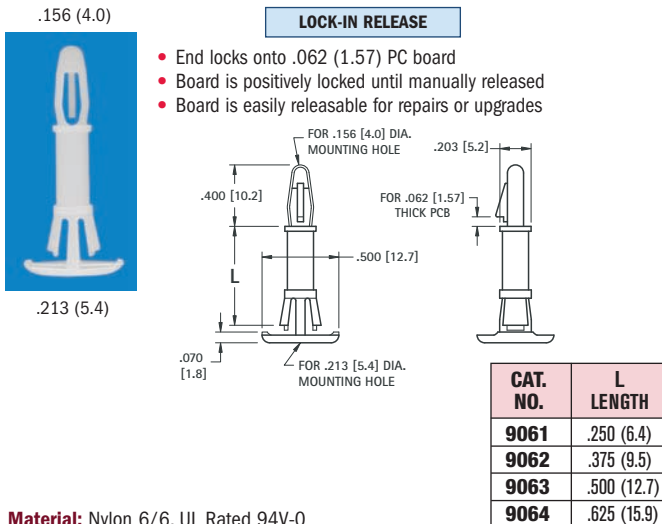

CAT. NO.	L LENGTH
9061	.250 (6.4)
9062	.375 (9.5)
9063	.500 (12.7)
9064	.625 (15.9)

**Material:** Nylon 6/6, UL Rated 94V-0

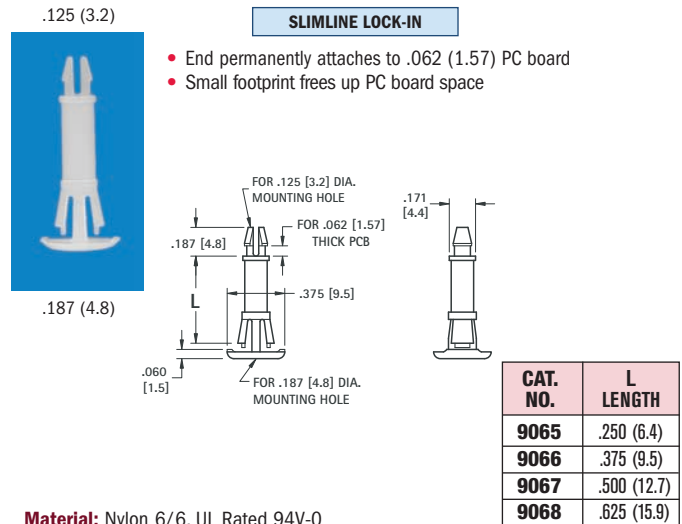

CAT. NO.	L LENGTH
9065	.250 (6.4)
9066	.375 (9.5)
9067	.500 (12.7)
9068	.625 (15.9)

**Material:** Nylon 6/6, UL Rated 94V-0