



Chipsmall Limited consists of a professional team with an average of over 10 year of expertise in the distribution of electronic components. Based in Hongkong, we have already established firm and mutual-benefit business relationships with customers from,Europe,America and south Asia,supplying obsolete and hard-to-find components to meet their specific needs.

With the principle of “Quality Parts,Customers Priority,Honest Operation,and Considerate Service”,our business mainly focus on the distribution of electronic components. Line cards we deal with include Microchip,ALPS,ROHM,Xilinx,Pulse,ON,Everlight and Freescale. Main products comprise IC,Modules,Potentiometer,IC Socket,Relay,Connector.Our parts cover such applications as commercial,industrial, and automotives areas.

We are looking forward to setting up business relationship with you and hope to provide you with the best service and solution. Let us make a better world for our industry!



Contact us

Tel: +86-755-8981 8866 Fax: +86-755-8427 6832

Email & Skype: info@chipsmall.com Web: www.chipsmall.com

Address: A1208, Overseas Decoration Building, #122 Zhenhua RD., Futian, Shenzhen, China



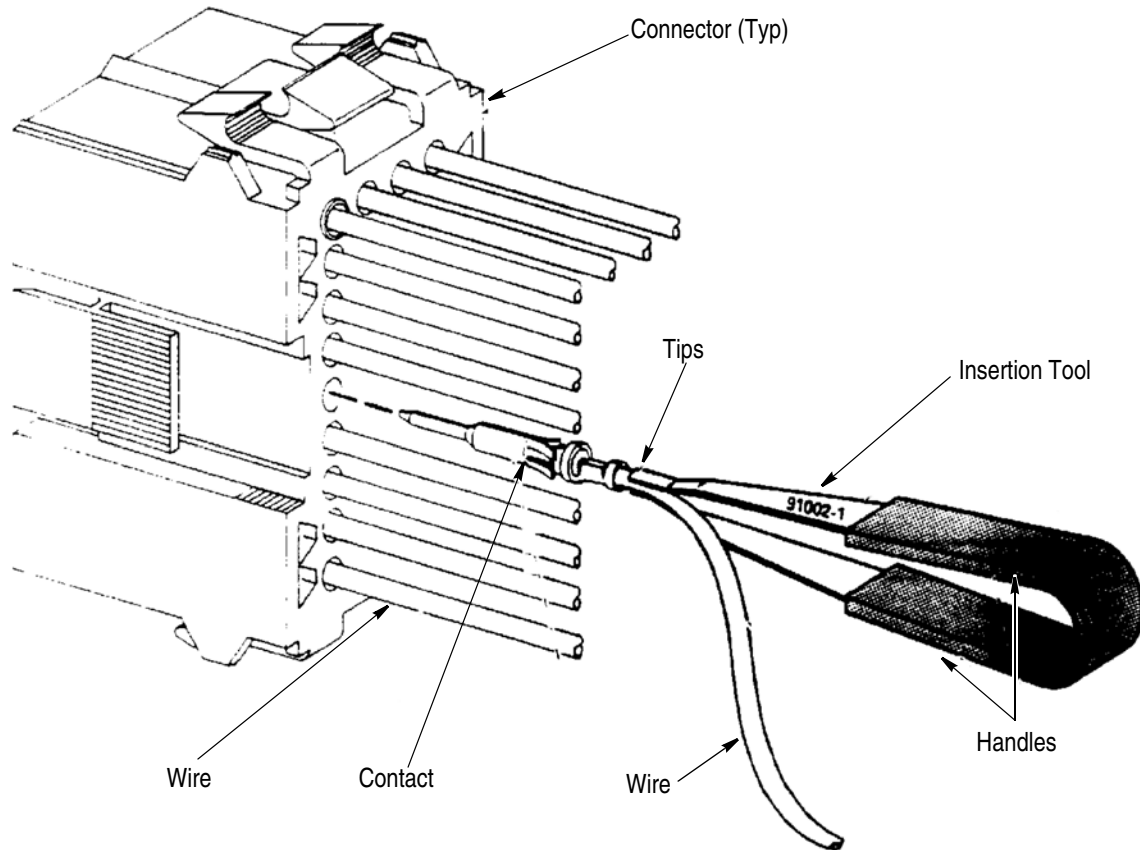

Figure 1

1. INTRODUCTION

This instruction sheet covers the use of insertion tools 91002-1 and 91002-2 which are designed to insert pin and socket contacts (which are crimped to small, fragile wires) into connectors.

Read these instructions thoroughly before inserting any contacts.



All dimensions on this instruction sheet are in millimeters [with inch equivalents in brackets.]

2. DESCRIPTION (Figure 1)

This tweezer-shaped tool features two grooved insertion tips for grasping the wire connected to the contact and tool handles which assist in applying even pressure to the insertion tips.

The tool is designed for 2.286 mm [.090-in.] maximum diameter insulation. but the tool can also be used with other types of wire if caution is used during insertion.



To determine whether the insertion tool is needed in an application, refer to the instruction sheet packaged with the product or check with your local TE representative.

3. INSERTION PROCEDURES (Figure 1)

Insert the contact as follows:

1. Place the insertion tool over the wire, with tool insertion tips behind the contact.
2. Squeeze tips together to hold the wire and contact in position.
3. Align the contact with back of contact cavity in the housing, and insert the contact into housing until it is fully seated.

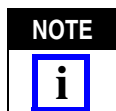

Some contact cavities will not permit entry of the tool tips. If the contact is not fully inserted, grasp the wire further back from the contact and push the contact in again until it is fully seated.

4. Release pressure on tool tips and remove tool.

5. Pull back lightly on wire to make sure the contact is locked in place.

We recommend that you inspect the tool immediately upon arrival in your factory and at regularly scheduled intervals to ensure that the tooling has not been damaged.

4. TOOL INSPECTION

The tool listed in this instruction sheet should be inspected with the information provided in Figure 2.

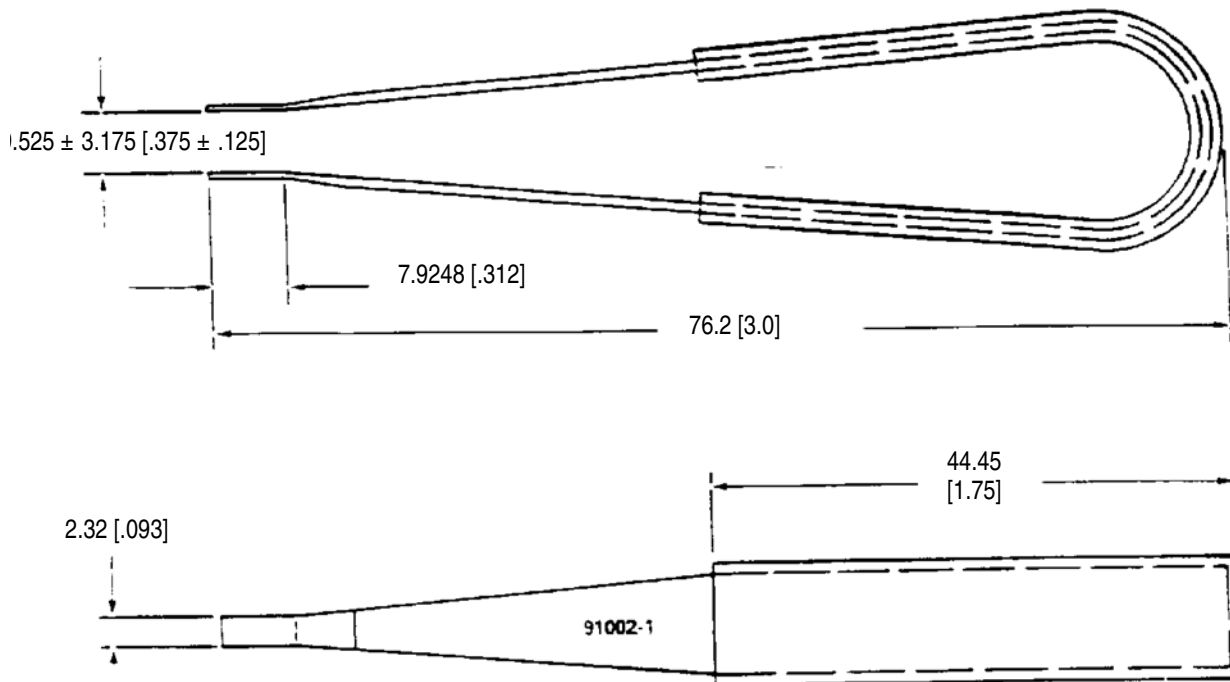

Figure 2

5. REVISION SUMMARY

Revisions to this instruction sheet include:

- Changed company name and logo