



Chipsmall Limited consists of a professional team with an average of over 10 year of expertise in the distribution of electronic components. Based in Hongkong, we have already established firm and mutual-benefit business relationships with customers from,Europe,America and south Asia,supplying obsolete and hard-to-find components to meet their specific needs.

With the principle of “Quality Parts,Customers Priority,Honest Operation,and Considerate Service”,our business mainly focus on the distribution of electronic components. Line cards we deal with include Microchip,ALPS,ROHM,Xilinx,Pulse,ON,Everlight and Freescale. Main products comprise IC,Modules,Potentiometer,IC Socket,Relay,Connector.Our parts cover such applications as commercial,industrial, and automotives areas.

We are looking forward to setting up business relationship with you and hope to provide you with the best service and solution. Let us make a better world for our industry!



Contact us

Tel: +86-755-8981 8866 Fax: +86-755-8427 6832

Email & Skype: info@chipsmall.com Web: www.chipsmall.com

Address: A1208, Overseas Decoration Building, #122 Zhenhua RD., Futian, Shenzhen, China



AMPAMP INCORPORATED
HARRISBURG, PA 17105AMP* INSERTION/EXTRACTION
TOOL 91232-1

REDUCED FOR PACKAGING

IS 6631

CUSTOMER HOTLINE

1 800 722-1111

RELEASED

12-15-88

INSERTING CONTACTS

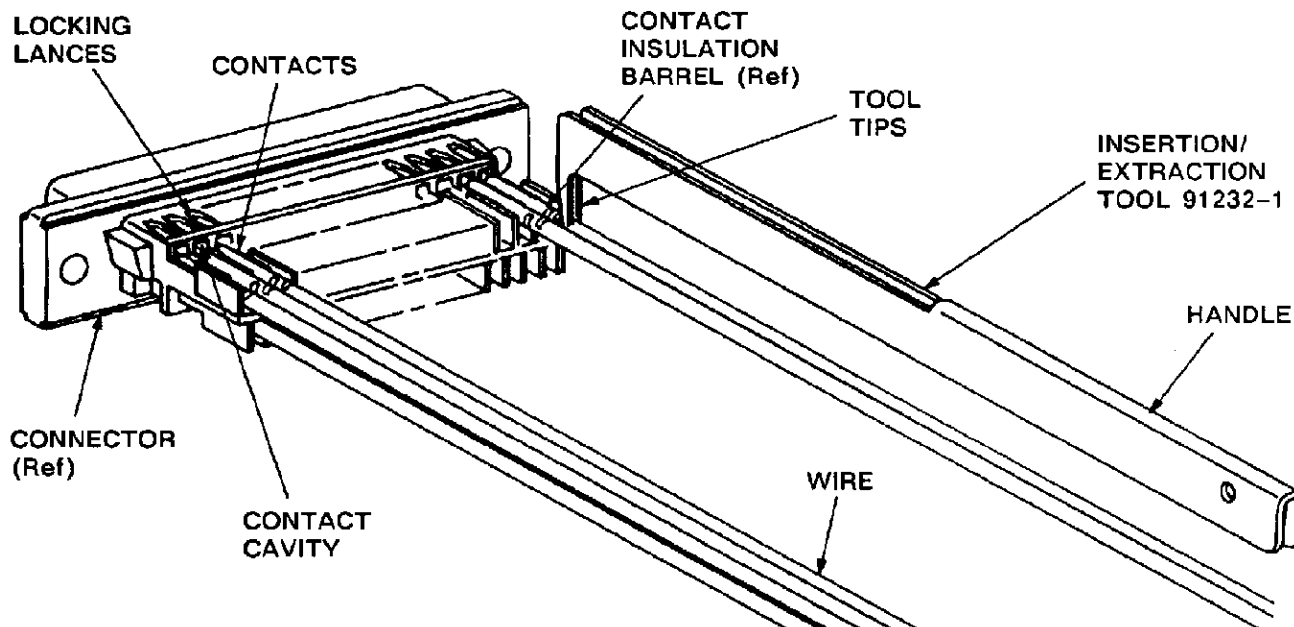

CONTACTS		CONNECTORS						
745266	745888	745201	745211	745493	745498	747532	747943	747948
745267	745889	745203	745213	745494	745664	747547	747944	747949
745269	745890	745205	745215	745495	747515	747548	747945	747950
745270	745930	745207	745491	745496	747516	747563	747946	—
745887	745931	745209	745492	745497	747531	747564	747947	—

Fig. 1

1. INTRODUCTION

AMP Insertion/Extraction Tool 91232-1 is designed to insert or extract AMPLIMITE* HDE pin and socket contacts into or from HDE connectors. The tweezer-shaped tool features two tips for grasping the contact lances which lock the contact into the housing, and a handle which assists in applying even pressure to the tool tips. Refer to Figure 1 for the selection of HDE contacts and connectors.

Read these instructions thoroughly before using the tool.

NOTE

All dimensions on this instruction sheet are in inches.

2. INSERTION PROCEDURE (Figure 1)

1. Grasp wire with tool tips at the rear of the contact insulation barrel.
2. Insert contact into contact cavity until the contact locking lances engage.
3. Remove the tool. Pull back lightly on the wire to make certain contact is locked in the contact cavity.

3. EXTRACTION PROCEDURE (Figure 2)

1. Insert tool tips into front of contact cavity over the tapered points of contact locking lances.
2. Keeping tool tips bottomed, slightly squeeze tips together and pull back on the tool. The tips will depress locking lances and start contact out of the cavity.
3. Remove tool from the contact cavity.
4. Grasp wire and pull contact out of cavity.

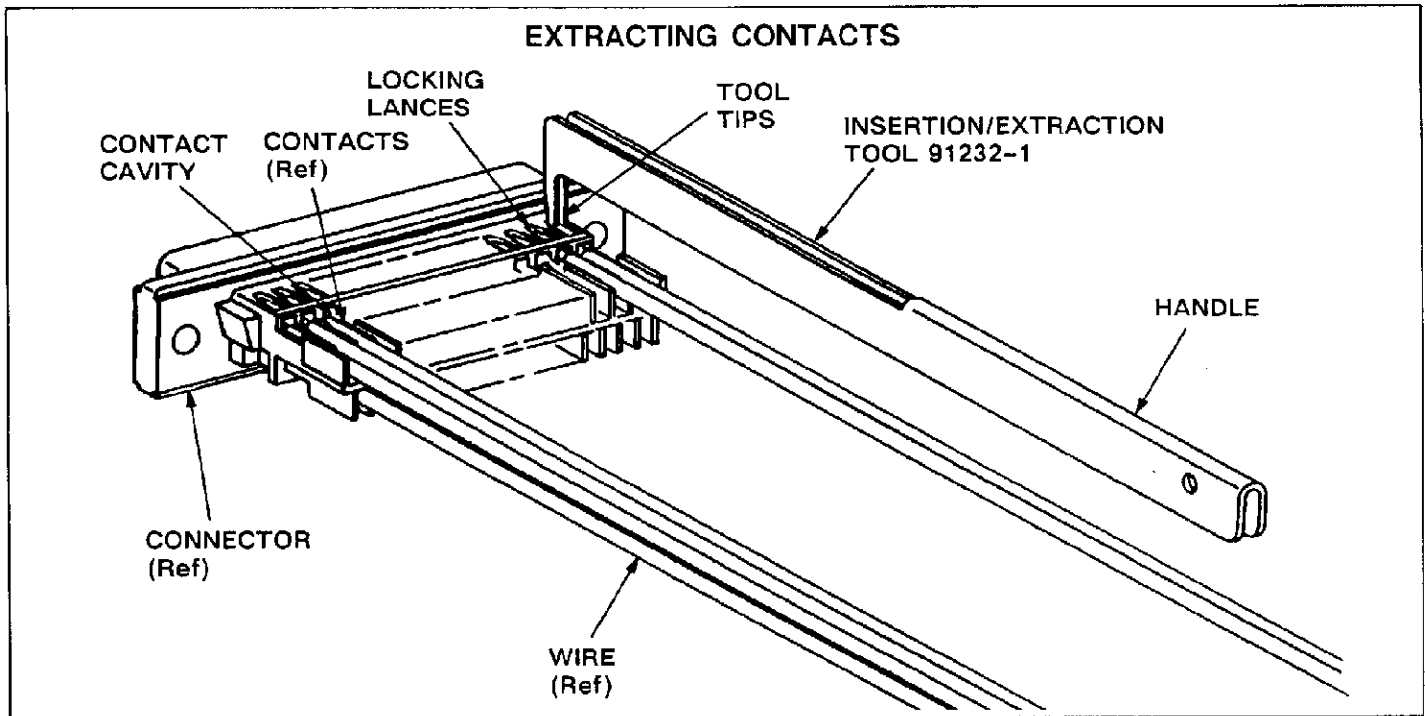

Fig. 2

4. TOOL INSPECTION

AMP Insertion/Extraction Tool 91232-1 is inspected before shipment. AMP recommends that the tool be inspected immediately upon arrival in your facility to ensure that the tool has not been damaged during shipment, and that the tool conforms to the dimensions provided in Figure 3.

Additional tools can be purchased by contacting:

AMP Incorporated
 P.O. Box 3608
 Harrisburg, PA 17105-3608

or a wholly owned subsidiary of AMP Incorporated.

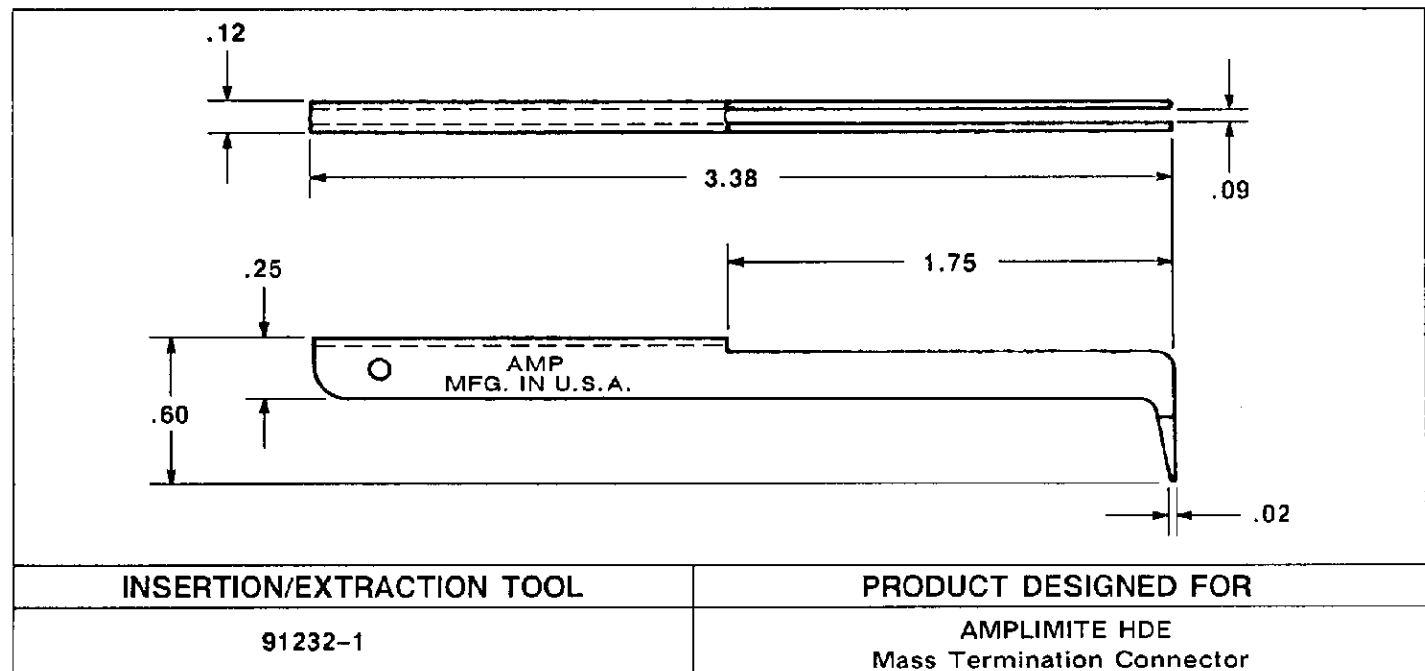

Fig. 3