



Chipsmall Limited consists of a professional team with an average of over 10 year of expertise in the distribution of electronic components. Based in Hongkong, we have already established firm and mutual-benefit business relationships with customers from,Europe,America and south Asia,supplying obsolete and hard-to-find components to meet their specific needs.

With the principle of “Quality Parts,Customers Priority,Honest Operation,and Considerate Service”,our business mainly focus on the distribution of electronic components. Line cards we deal with include Microchip,ALPS,ROHM,Xilinx,Pulse,ON,Everlight and Freescale. Main products comprise IC,Modules,Potentiometer,IC Socket,Relay,Connector.Our parts cover such applications as commercial,industrial, and automotives areas.

We are looking forward to setting up business relationship with you and hope to provide you with the best service and solution. Let us make a better world for our industry!



## Contact us

Tel: +86-755-8981 8866 Fax: +86-755-8427 6832

Email & Skype: info@chipsmall.com Web: www.chipsmall.com

Address: A1208, Overseas Decoration Building, #122 Zhenhua RD., Futian, Shenzhen, China



Tous droits strictement réservés. Reproduction ou communication à des tiers interdite sous quelque forme que ce soit sans autorisation écrite du propriétaire. © FCI b.v.



Reproduction or issue to third parties in any form, whatever is not permitted without written authority from the proprietor. © FCI b.v.

All rights strictly reserved. Reproduction or issue to third parties in any form, whatever is not permitted without written authority from the proprietor. © FCI b.v.

form: A3

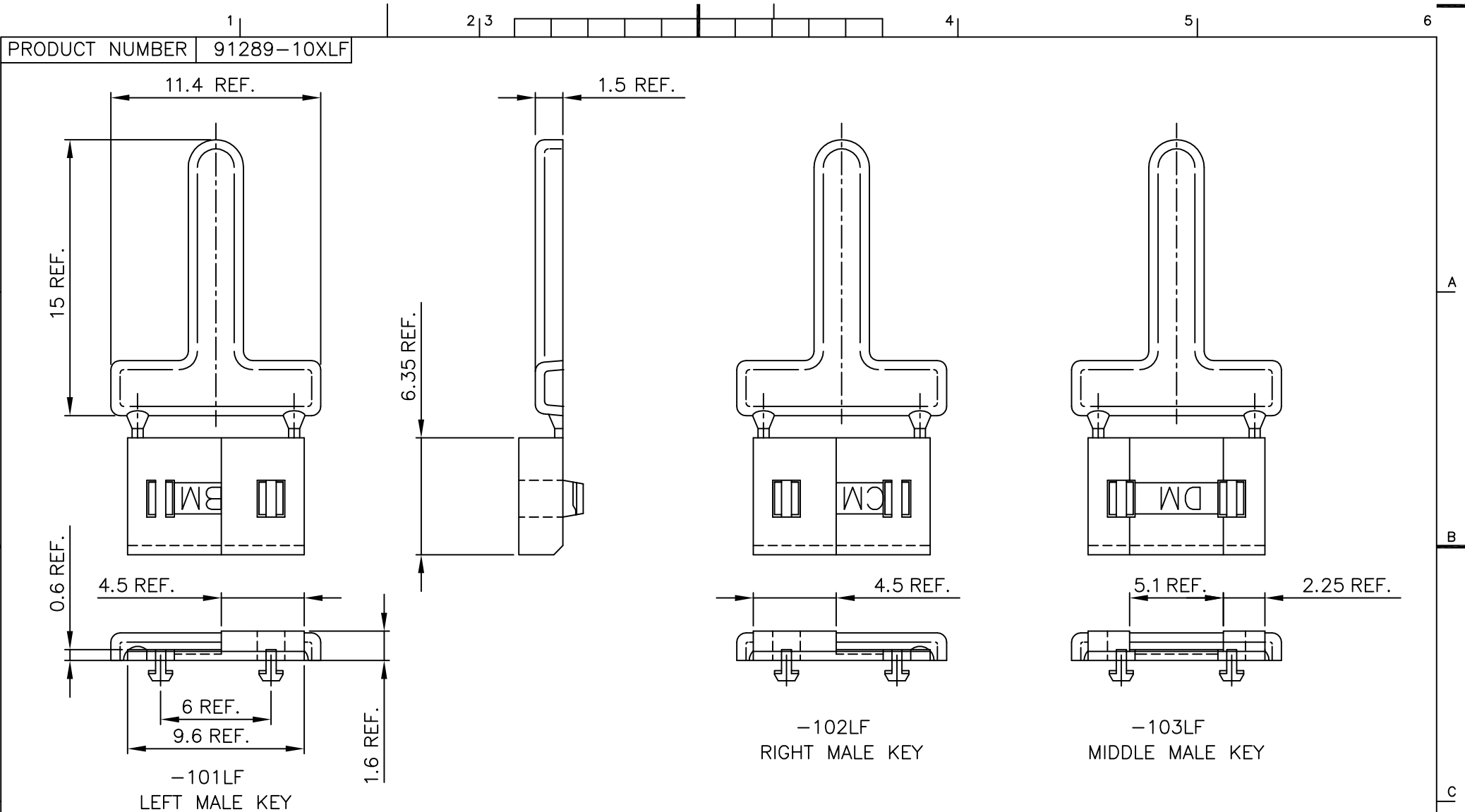

NOTES:

- MATERIAL: LIQUID CRYSTAL POLYMER. FLAME RETARDANT ACC. UL 94-V0 30% GLASS FILLED, COLOR: SEE TABLE.
- PRODUCT TO BE DELIVERED TO THE CUSTOMER WITH THE RUNNER ATTACHED
- THIS PRODUCT WITH "LF" SUFFIX MEETS EUROPEAN UNION DIRECTIVES AND OTHER COUNTRY REGULATIONS AS DESCRIBED IN GS -22-008.
- THE PRODUCT IS NOT INTENDED TO BE EXPOSED TO A MANUFACTURING SOLDER PROCESS.

PRODUCT NUMBER	COLOR
91289-101LF	BLUE
91289-102LF	PINK
91289-103LF	BROWN

mat'l. code SEE NOTE 1		tolerances unless otherwise specified		CUSTOMER COPY		<b>ELECTRONICS</b> www.fciconnect.com	
ltr	ecn no	dr	date	linear	projection	title	
A	V41309	RDO	940729			MALE HALF KEYS	
B	H40388	RV	940810	angles		product family	
C	H40583	DDB	940916			CENTRAL (tm)	
D	bg05-0382	Clu	051011	dr	D. de Bil	940609	code
				engr	E. Feijen	940729	213
				chr	G.S. Lee	940609	sheet
				appd	G.S. Lee	940609	1 of 1
sheet index	revision	D					
	sheet	1					