



Chipsmall Limited consists of a professional team with an average of over 10 year of expertise in the distribution of electronic components. Based in Hongkong, we have already established firm and mutual-benefit business relationships with customers from,Europe,America and south Asia,supplying obsolete and hard-to-find components to meet their specific needs.

With the principle of "Quality Parts,Customers Priority,Honest Operation,and Considerate Service",our business mainly focus on the distribution of electronic components. Line cards we deal with include Microchip,ALPS,ROHM,Xilinx,Pulse,ON,Everlight and Freescale. Main products comprise IC,Modules,Potentiometer,IC Socket,Relay,Connector.Our parts cover such applications as commercial,industrial, and automotives areas.

We are looking forward to setting up business relationship with you and hope to provide you with the best service and solution. Let us make a better world for our industry!



## Contact us

Tel: +86-755-8981 8866 Fax: +86-755-8427 6832

Email & Skype: info@chipsmall.com Web: www.chipsmall.com

Address: A1208, Overseas Decoration Building, #122 Zhenhua RD., Futian, Shenzhen, China



**Keying Tool 91417-1**

Figure 1

**1. INTRODUCTION**

Keying Tool 91417-1 shown in Figure 1 is designed to remove 0.64-mm [.025-in.] square contact pins without shoulders from AMPMODU\* MTE pin headers (reference base part numbers 87215, 102570, and 103169). The pin header is keyed by removing the contact pin that align with keying plugs in the mating connector. The pin header can be keyed before or after the connector is attached to a printed circuit (pc) board.

Read this instruction sheet thoroughly before using the keying tool.

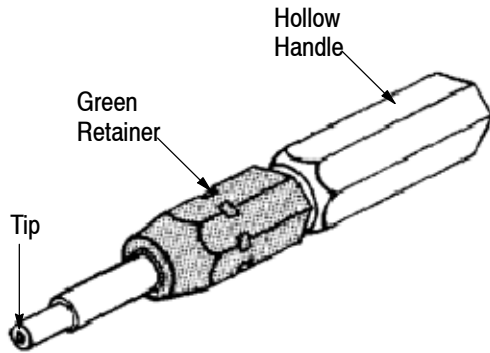
**NOTE**

Dimensions in this instruction sheet are in millimeters [with inches in brackets]. Figures are not drawn to scale.

**CAUTION**

DO NOT use this tool for headers having contact pins with shoulders. Use Keying Tool 843853-1 according to Instruction Sheet 408-9454.

Reasons for reissue of this instruction sheet are provided in Section 6, REVISION SUMMARY.

**2. DESCRIPTION**

The keying tool features a tip, hollow handle, retainer (green), and gage bushing (inside the retainer).

**3. USING THE KEYING TOOL**

1. Determine which contact pin(s) will align with a keying plug in the mating connector. See Figure 2.
2. From the mating face of the pin header, align the tip of the tool with the contact pin to be removed as shown in Figure 3.

3. Place the tool tip over the contact pin until it bottoms on the mating face of the pin header; make sure the contact pin has seated in the tool tip.
4. Keeping the tool tip seated on the mating face, twist the tool handle — in either direction — until the contact pin snaps off.
5. Extract the tool. It is not necessary to remove the contact pin from the tip of the tool since it will push through the hollow handle when the tool tip is placed over the next contact pin.
6. Repeat Steps 1 through 5 until all of the applicable contact pins have been twisted off.

**NOTE**

Before mating the pin header with the connector, align the pin header with the connector and check to be sure all contact pins that align with keying plugs have been removed.

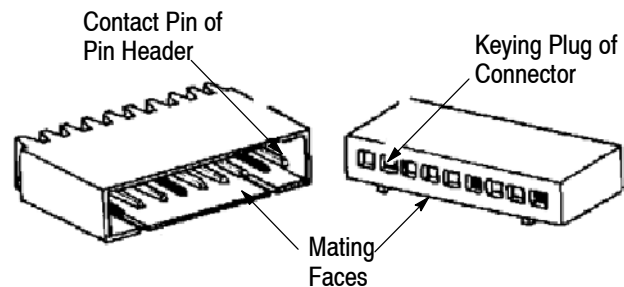

**Note:** For Clarity, Contact Pins and Keying Plugs that Must be Removed are Shown Darkened

Figure 2

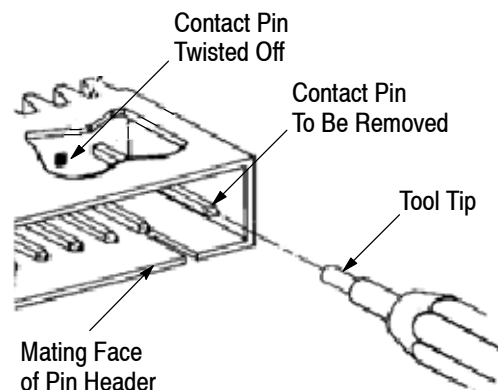

Figure 3

#### 4. MAINTENANCE AND INSPECTION

The keying tool should conform to the dimensions provided in Figure 4. It is recommended that each tool be inspected upon arrival to be sure it has not been damaged in transit, and at regularly scheduled intervals to be sure it remains functional.

#### 5. REPLACEMENT AND REPAIR

Order replacement keying tools through your representative, or call 1-800-526-5142, or send a facsimile of your purchase order to 717-986-7605, or write to:

CUSTOMER SERVICE (038-035)  
 TYCO ELECTRONICS CORPORATION  
 PO BOX 3608  
 HARRISBURG PA 17105-3608

#### 6. REVISION SUMMARY

Revisions to this instruction sheet include:

- Updated instruction sheet to corporate requirements

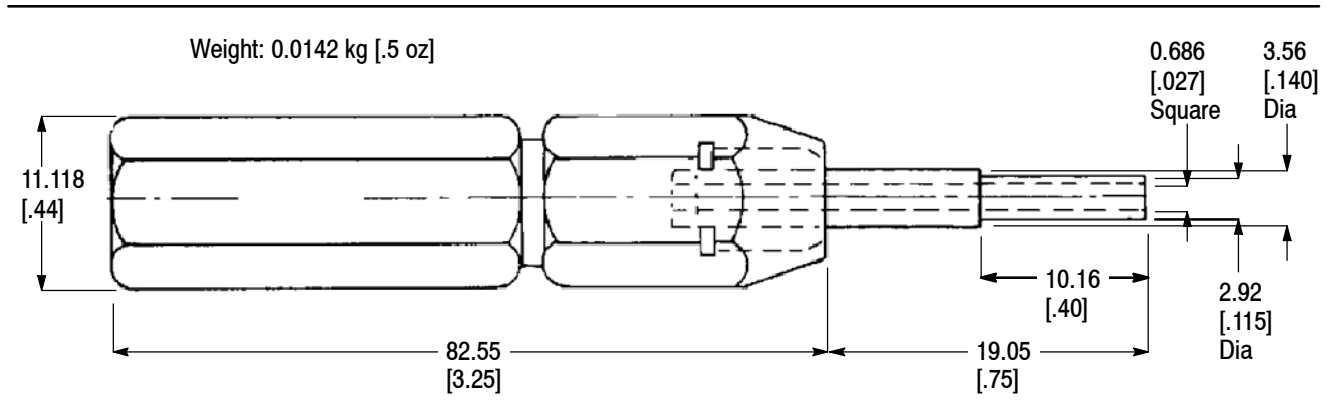

Figure 4