



Chipsmall Limited consists of a professional team with an average of over 10 year of expertise in the distribution of electronic components. Based in Hongkong, we have already established firm and mutual-benefit business relationships with customers from,Europe,America and south Asia,supplying obsolete and hard-to-find components to meet their specific needs.

With the principle of “Quality Parts,Customers Priority,Honest Operation,and Considerate Service”,our business mainly focus on the distribution of electronic components. Line cards we deal with include Microchip,ALPS,ROHM,Xilinx,Pulse,ON,Everlight and Freescale. Main products comprise IC,Modules,Potentiometer,IC Socket,Relay,Connector.Our parts cover such applications as commercial,industrial, and automotives areas.

We are looking forward to setting up business relationship with you and hope to provide you with the best service and solution. Let us make a better world for our industry!



Contact us

Tel: +86-755-8981 8866 Fax: +86-755-8427 6832

Email & Skype: info@chipsmall.com Web: www.chipsmall.com

Address: A1208, Overseas Decoration Building, #122 Zhenhua RD., Futian, Shenzhen, China



PRODUCT NO	NUMBER OF POS.	LOADED POSITION	LEAD FREE OPTION	COLOR
92250-X88	8	ALL POS.	NOTE 6 & 8	BLACK
92250-X86		2,3,4,5,6,7		
92250-X84		3,4,5,6		
92250-X88G		ALL POS.		GRAY

NOTE: PLEASE CHECK FOR AVAILABILITY, NOT ALL OPTIONS AVAILABLE.

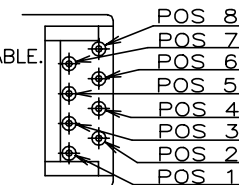

POS. NO. CONFIGURATION

PLATING CODE X	PLATING
0	5u" Au + high performance lubricant
1	15u" GXT
3	5u" Au + high performance lubricant
5	50u" GXT

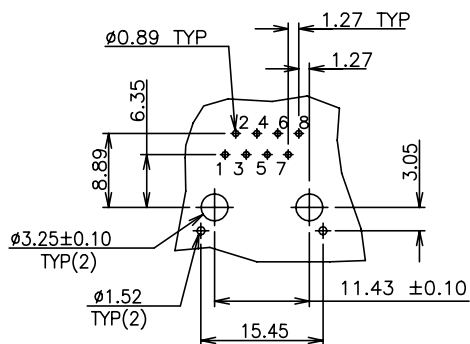
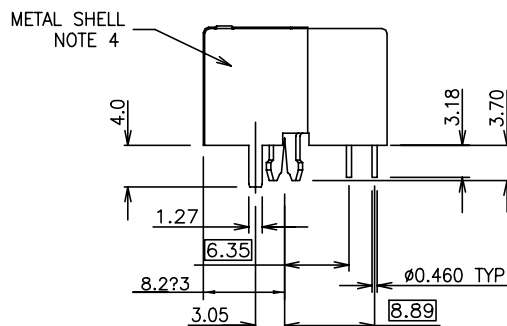
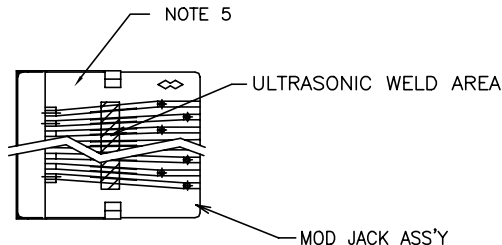
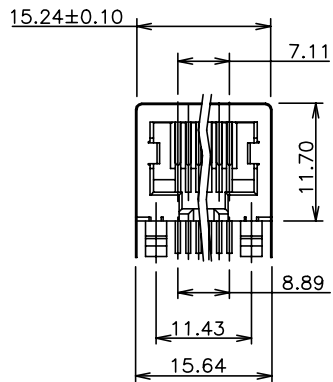

P.C.B. HOLE PATTERN VIEWED FROM TOP.

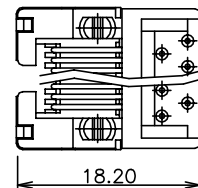

NOTE: PLEASE CHECK FOR AVAILABILITY, NOT ALL OPTIONS AVAILABLE.

NOTES:

- RECOMMENDED P.C.B THICKNESS 1.60 MM
- HOUSING MAT'L: NYLON 6/6, 25% GLASS REINFORCED,
- CONTACTS: PHOS BRONZE ALLOY UNS-C51000, Ø 0.460 ROUND WIRE, PLATING SEE TABLE.
- SHIELDING MATERIAL:
0.25 [0.010] THICK BRASS ALLOY 2.54µ/100?
TIN-LEAD PLATED, OVER 1.02µ/40? MIN NICKEL UNDERPLATING
PER BUS-15-002/M.
LEAD FREE OPTION:
0.25 [0.010] THICK BRASS ALLOY 2.03µ/80?
TIN PLATED, OVER 1.02µ/40? MIN NICKEL UNDERPLATING
PER BUS-15-002/M.
- COMPANY LOGO LOCATED IN THIS AREA.
- ADD LF SUFFIX AT THE END OF PART NUMBER FOR LEAD FREE OPTION.
- THE HOUSING WILL WITHSTAND EXPOSURE TO 260°C PEAK TEMPERATURE FOR 15 SECONDS IN A WAVE SOLDER APPLICATION WITH A 1.5mm MINIMUM THICK CIRCUIT BOARD. SEE APPLICATION NOTES/PROCEDURES IF THEY ARE AVAILABLE.
- THIS PRODUCT MEETS EUROPEAN UNION DIRECTIVES AND OTHER COUNTRY REGULATION AS DESCRIBED IN GS-22-008.
- PLATING OPTIONS:
MAY BE EITHER GOLD OR GXT PLATED AT MANUFACTURER'S OPTION.
- EQUIVALENT THICKNESS Au AND GXT PLATING HAVE SAME FUNCTION AND THEY ARE ALTERNATIVE BY THE CUSTOMER.

mat'l. code	surface ISO1302 ✓	tolerance ISO1101 ISO406	projection mm	product family MOD JACK
l t r e c n n o d r	date	tolerances unless otherwise specified	scale 1.0	title
K N06-256 WG	12/05/06	0.X±0.3	mm	LOW PROFILE PCB III
L N08-0097 SH	09/24/08	0.XX±0.15		8 POS SHIELDED M/J
M ELX-N-010688 SH MM0	3/14/12	0.XXX±0.05		
dr	K.CHEN	6/27/92		dwg no
engr	TONY CHEN	6/27/92		sheet 1 of 1
chr	TONY CHEN	6/27/92		size
appd	JENN TSAO	6/27/92		92250
sheet index	revision sheet 1			A4
				type Product Customer Drawing