



Chipsmall Limited consists of a professional team with an average of over 10 year of expertise in the distribution of electronic components. Based in Hongkong, we have already established firm and mutual-benefit business relationships with customers from,Europe,America and south Asia,supplying obsolete and hard-to-find components to meet their specific needs.

With the principle of “Quality Parts,Customers Priority,Honest Operation,and Considerate Service”,our business mainly focus on the distribution of electronic components. Line cards we deal with include Microchip,ALPS,ROHM,Xilinx,Pulse,ON,Everlight and Freescale. Main products comprise IC,Modules,Potentiometer,IC Socket,Relay,Connector.Our parts cover such applications as commercial,industrial, and automotives areas.

We are looking forward to setting up business relationship with you and hope to provide you with the best service and solution. Let us make a better world for our industry!



Contact us

Tel: +86-755-8981 8866 Fax: +86-755-8427 6832

Email & Skype: info@chipsmall.com Web: www.chipsmall.com

Address: A1208, Overseas Decoration Building, #122 Zhenhua RD., Futian, Shenzhen, China



ZEICHNUNG GESCHÜTZT DURCH
 © COPYRIGHT 1980
 AMP DEUTSCHLAND GMBH
 ALLE RECHTE VORBEHALTEN

ÄNDERUNGEN, DIE DEM
 TECHNISCHEN FORT-
 SCHRITT DIENEN, BE-
 HALTEN WIR UNS VOR

REV.	ÄNDERUNG	DATUM	NAME
A	DESIGN-ÄNDERUNG	15.1.80	PEINZE
B	ZEICHN. NEU ERST.	22.8.88	A.HO
C	MAßLINIE BEI 5.5 KORRIGIERT	27.06.91	A.HO
D	-2 HINZU	18.12.91	CH.SCH

NUMMER 926 329

VERWENDET FÜR _

WAR NR. -

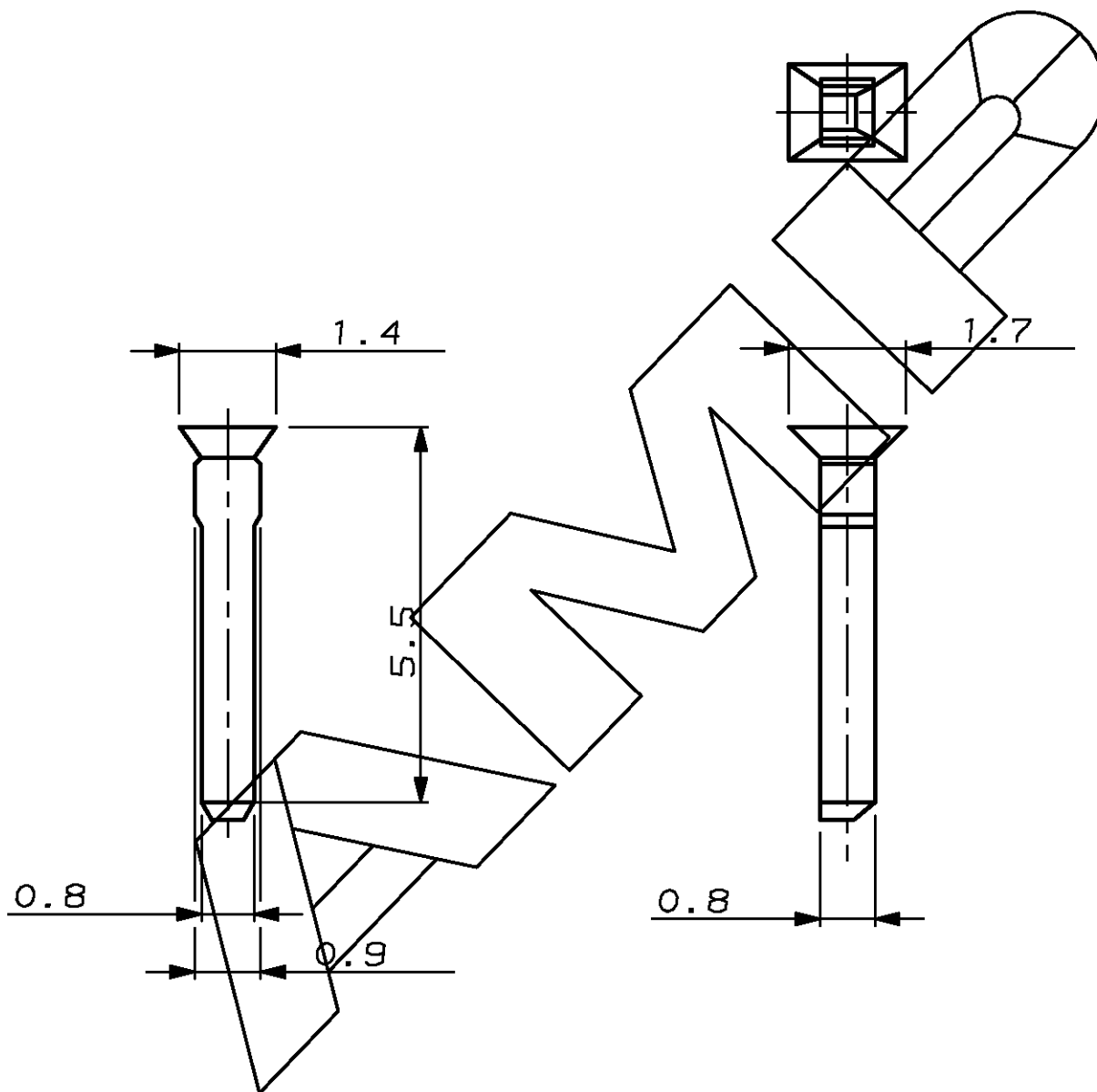

CAD-ORIGINAL
 ZEICHNUNG NICHT ÄNDERN

ZEICHNUNG GÜLTIG AB 51/91.

AMP AMP DEUTSCHLAND G.m.b.H.
 Langen b.Ffm., West Germany

Benennung
KODIERSTIFT **K**

926 329-2	PA 6.6 GV30	SCHWARZ
926 329-1	PA 6.6	NATUR

BESTELL-NR.	WERKSTOFF	OBERFLÄCHE	
		FARBE	
GEZ. 16.1.80	GEPR. 16.1.80	GEPR.	
PEINZE	MORITZ		

NICHT TOLERIERTE MASSE ± 0.2 ± -	FORMAT A4	ZEICHNUNGS-NR. 926329
MASSTAB -	BLATT 1 von 1	REV. D