



Chipsmall Limited consists of a professional team with an average of over 10 year of expertise in the distribution of electronic components. Based in Hongkong, we have already established firm and mutual-benefit business relationships with customers from,Europe,America and south Asia,supplying obsolete and hard-to-find components to meet their specific needs.

With the principle of “Quality Parts,Customers Priority,Honest Operation,and Considerate Service”,our business mainly focus on the distribution of electronic components. Line cards we deal with include Microchip,ALPS,ROHM,Xilinx,Pulse,ON,Everlight and Freescale. Main products comprise IC,Modules,Potentiometer,IC Socket,Relay,Connector.Our parts cover such applications as commercial,industrial, and automotives areas.

We are looking forward to setting up business relationship with you and hope to provide you with the best service and solution. Let us make a better world for our industry!



Contact us

Tel: +86-755-8981 8866 Fax: +86-755-8427 6832

Email & Skype: info@chipsmall.com Web: www.chipsmall.com

Address: A1208, Overseas Decoration Building, #122 Zhenhua RD., Futian, Shenzhen, China



PRODUCT NUMBER
95615-XXXXLF

PLATING

- 0 = 0.20µm GOLD/GXT ON CONTACT AREA
2µm MIN MATTE TIN ON TAIL
 - 1 = 0.76µm GOLD/GXT ON CONTACT AREA
2µm MIN MATTE TIN ON TAIL
 - 3 = 0.38µm GOLD/GXT ON CONTACT AREA
2µm MIN MATTE TIN ON TAIL
 - 5 = 0.38µm GXT FULL PLATED
 - 6 = 0.76µm GXT FULL PLATED
 - 7 = 0.76µm GOLD/GXT FULL PLATED
 - 9 = 0.20µm GOLD/GXT FULL PLATED
- 1.27µm Ni MIN UNDERPLATING

- RoHS COMPATIBLE, SEE NOTE 6
- PACKAGING, SEE NOTE 5
- TOTAL NB OF POSITIONS, 08 TO 34

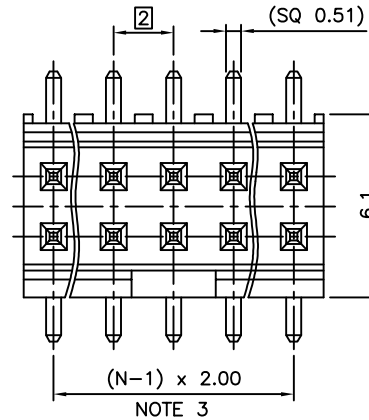

STANDARD PICK-UP CAP

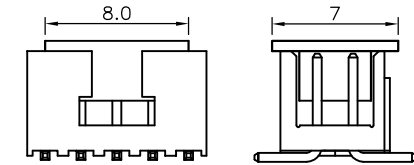
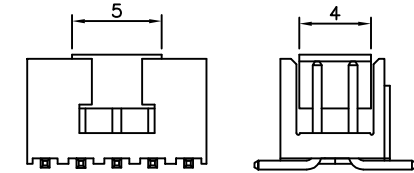

LARGE PICK-UP CAP NOTE 5
NOT AVAILABLE FOR 2X2

NOTES:

1. MATERIAL HOUSING: HIGH TEMP. THERMOPLASTIC
UL 94V-0, COLOR CREAM
2. MATERIAL TERMINAL: COPPER ALLOY
3. TO DETERMINE DIMENSIONS:
N = NUMBER OF POSITIONS PER ROW
4. 7N MIN. PIN RETENTION IN EITHER DIRECTION.
5. PACKAGING:

- = POLYBAGS
- T = TUBE AVAILABILITY : FROM 2x5 UP TO 2x 17
- B = TUBE WITH PICK UP CAP AVAILABLE FROM 2x5 UP TO 2x 17
- K = TAPE AND REEL WITHOUT PICK-UP CAP, AS AVAILABLE
- A = TAPE AND REEL WITH LARGE PICK-UP CAP, AS AVAILABLE
- TR = TAPE AND REEL WITH PICK-UP CAP, AS AVAILABLE.

6. RoHS COMPATIBLE PRODUCT SPECIFICATIONS

- a - PLATING:
 - "LF" MEANS THE PRODUCT IS LEAD-FREE,
2µm MINIMUM MATTE TIN OVER 1.27µm
MINIMUM NICKEL UNDERPLATE.
- b - MANUFACTURING PROCESS COMPATIBILITY
 - THE HOUSING WILL WITHSTAND EXPOSURE TO
260°C PEAK TEMPERATURE FOR 30 SECONDES
MAX IN A CONVECTION, INFRA-RED OR VAPOR
PHASE OR REFLOW OVEN.
- c - LABELLING:
 - MEETS PACKAGING SPECS AS PER GS-14-920
- d - THIS PRODUCT MEETS EUROPEAN DIRECTIVES
AND OTHER COUNTRY REGULATIONS AS DISCRIBED
IN GS-47-0004.

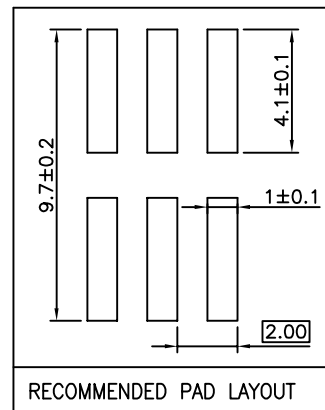
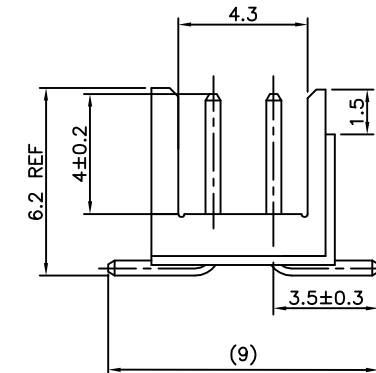
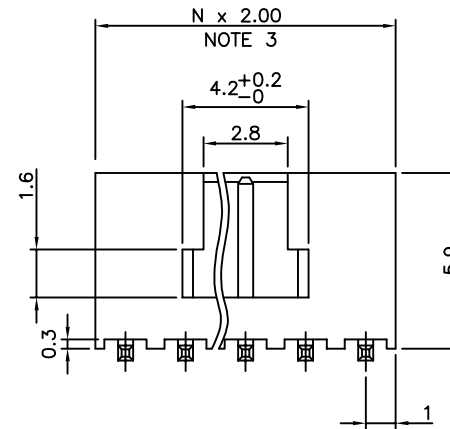

mat'l. code SEE NOTES		surface ISO 1302	tolerance ISO 406 ISO	projection 101	product family MINITEK HEADER
ltr	ecn no	dr	date	tolerances unless otherwise specified	title
T	F-23051	AMA	16.01.15	linear .X ±0.3 angles .XX ±0.13 .XXX ±0.05	SHR HEADER 2.00mm SMT
M	F07-0191	J.CO	07.09.05	±2'	scale 7:1
N	F08-0145	ELA	08.04.15	dr	JL.CORDIER 97.07.26
P	F11-0071	JCO	11.06.17	engr	J.COMPAGNON 97.07.26
R	F11-0339	JCO	11.12.06	chr	JL.CORDIER 97.07.26
S	B-19190	LMU	14.10.24	appo	J.COMPAGNON 97.07.26
sheet index	revision sheet				dwg no 95615
					sheet 1 of 1 size A3
					type CUSTOMER Drawing