



Chipsmall Limited consists of a professional team with an average of over 10 year of expertise in the distribution of electronic components. Based in Hongkong, we have already established firm and mutual-benefit business relationships with customers from,Europe,America and south Asia,supplying obsolete and hard-to-find components to meet their specific needs.

With the principle of “Quality Parts,Customers Priority,Honest Operation,and Considerate Service”,our business mainly focus on the distribution of electronic components. Line cards we deal with include Microchip,ALPS,ROHM,Xilinx,Pulse,ON,Everlight and Freescale. Main products comprise IC,Modules,Potentiometer,IC Socket,Relay,Connector.Our parts cover such applications as commercial,industrial, and automotives areas.

We are looking forward to setting up business relationship with you and hope to provide you with the best service and solution. Let us make a better world for our industry!



Contact us

Tel: +86-755-8981 8866 Fax: +86-755-8427 6832

Email & Skype: info@chipsmall.com Web: www.chipsmall.com

Address: A1208, Overseas Decoration Building, #122 Zhenhua RD., Futian, Shenzhen, China



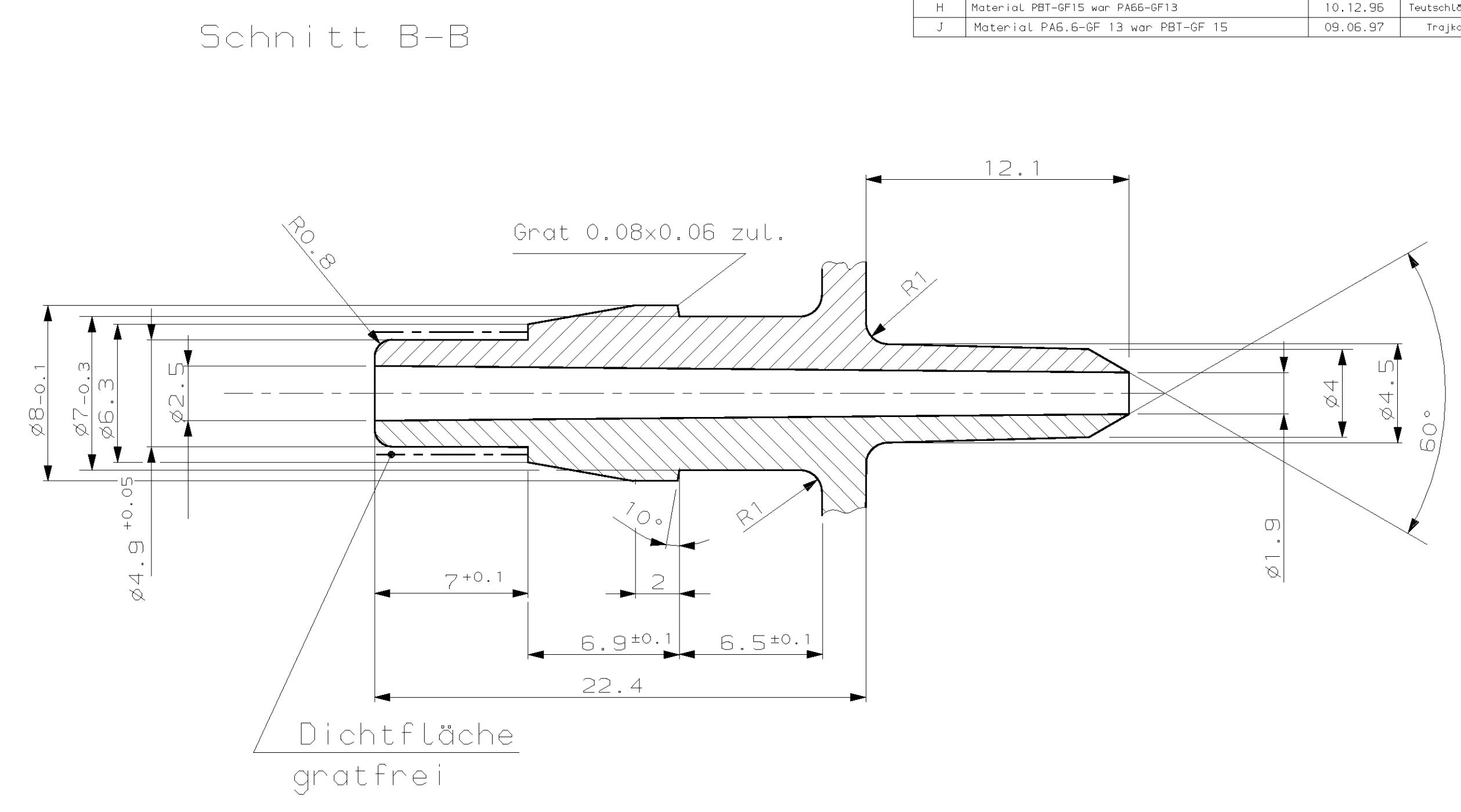
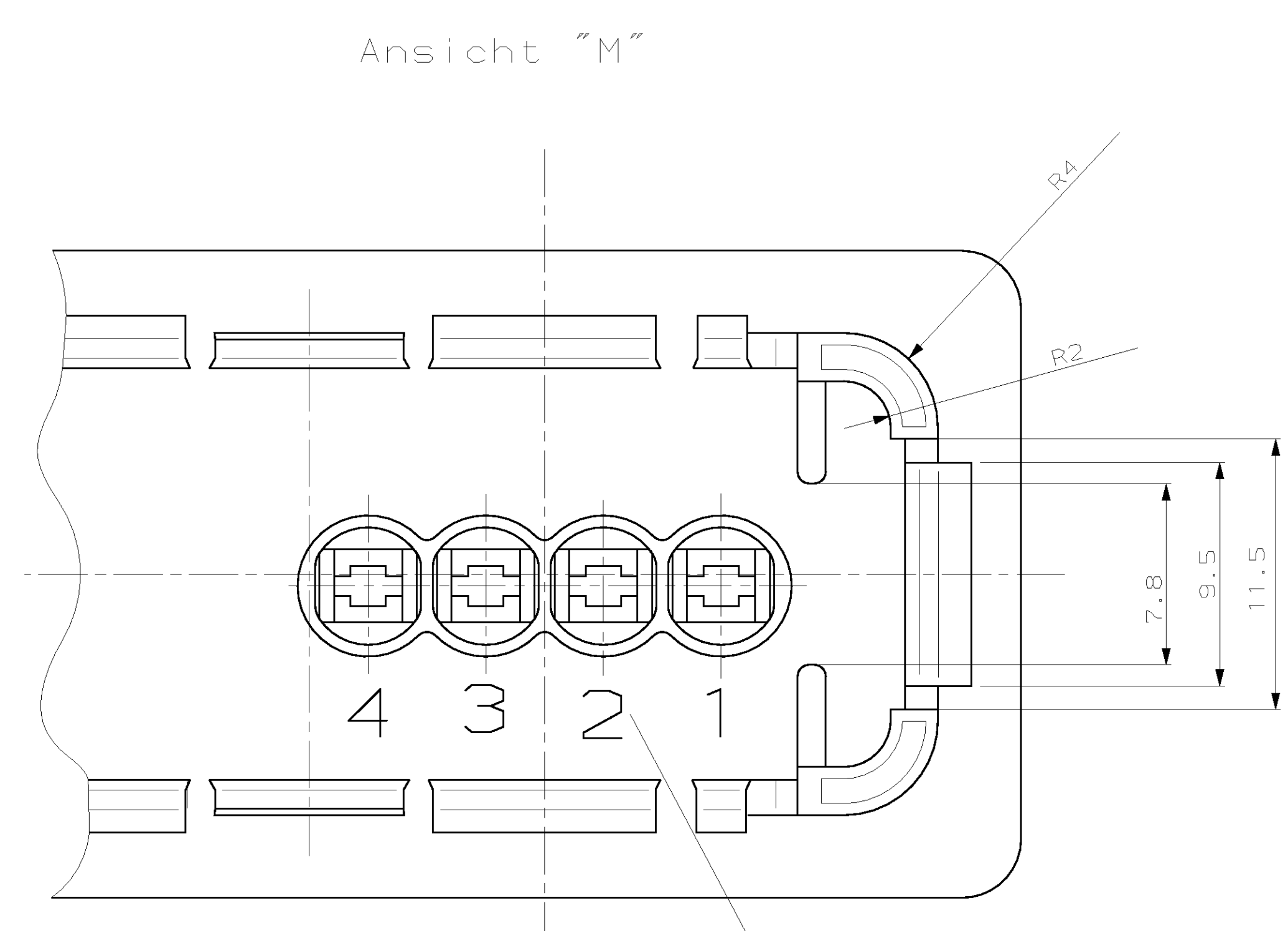
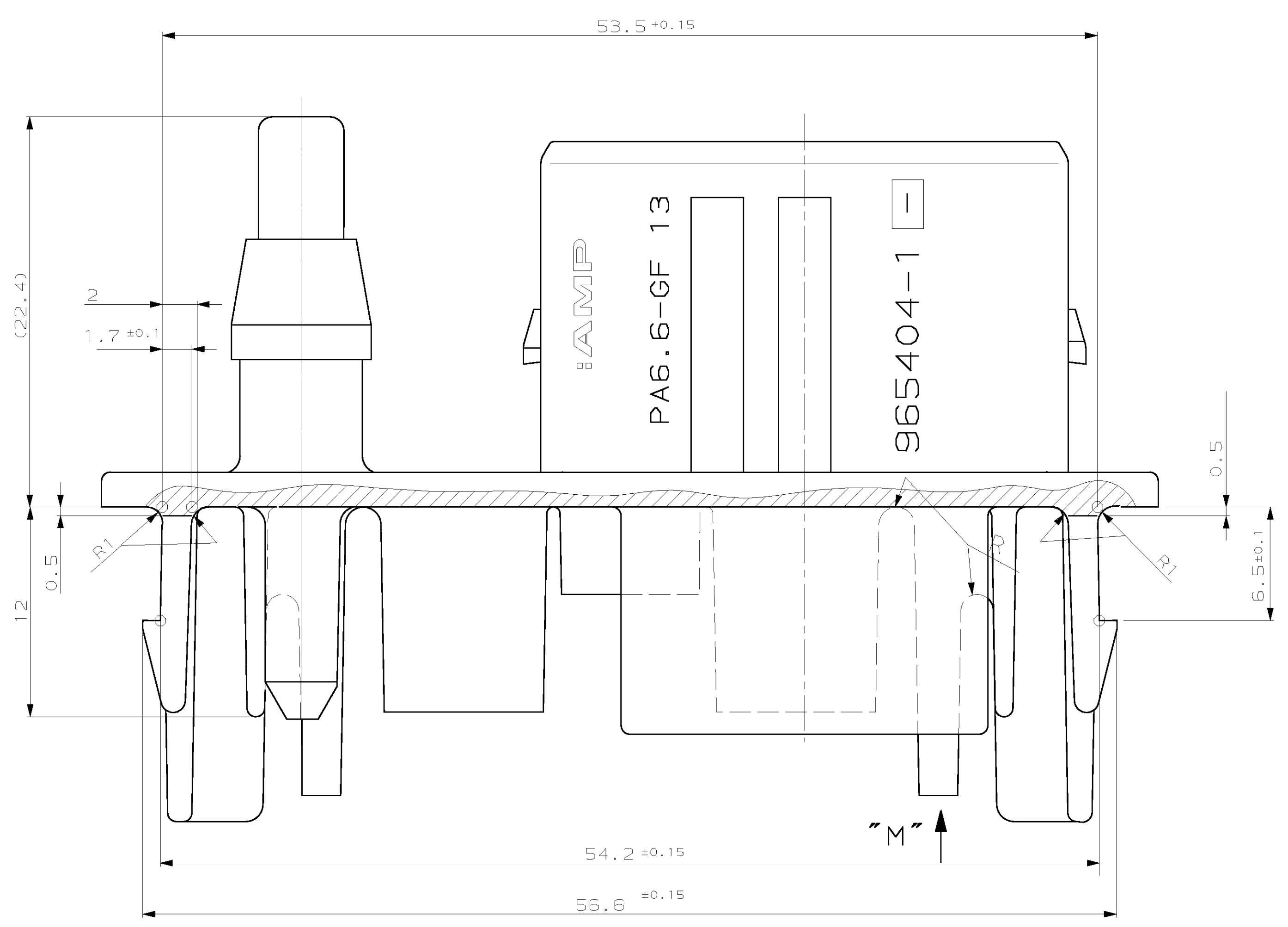

Schrift DIN 1451-H 2;
0.2 vertieft, 0.15 erhaben

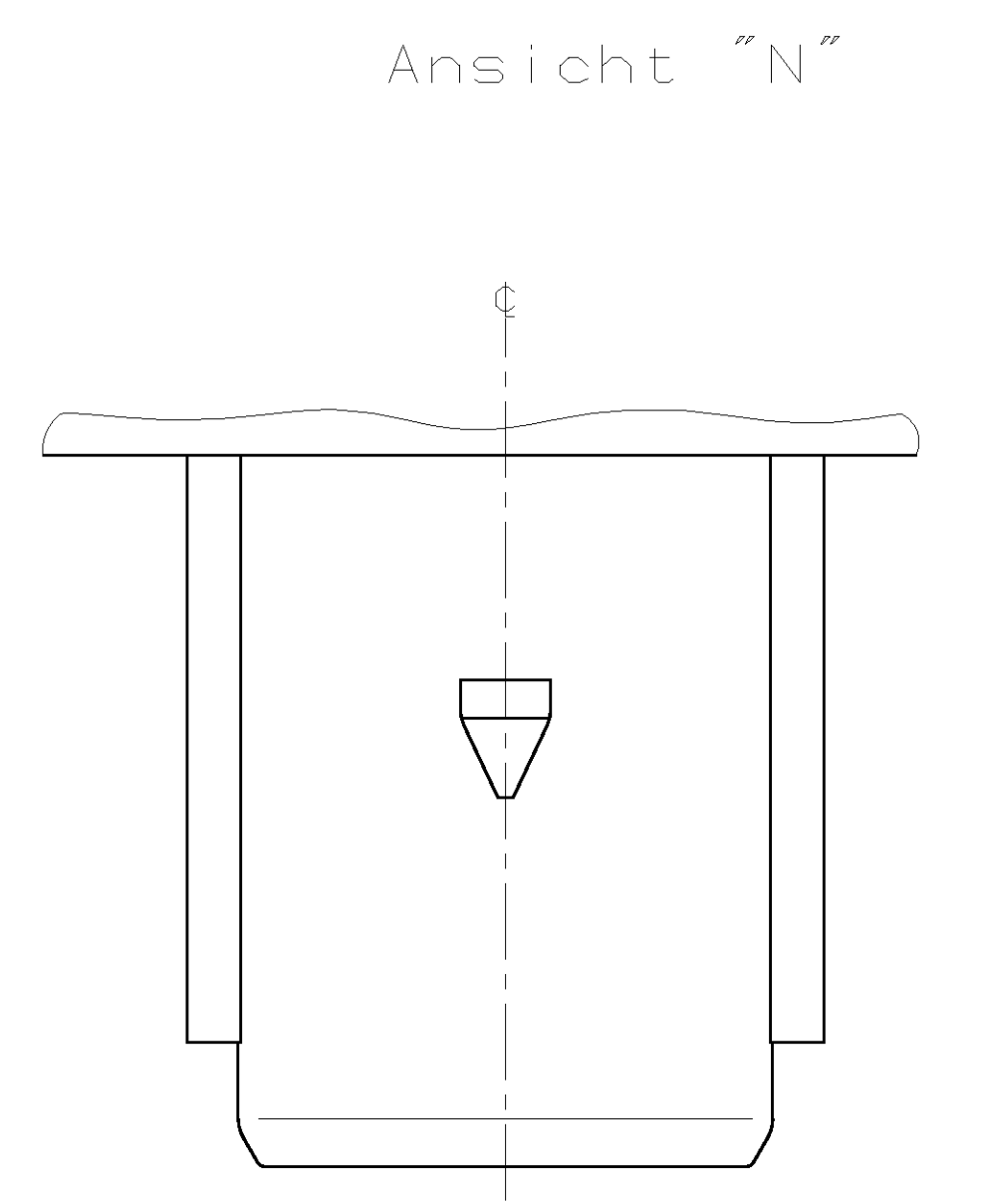
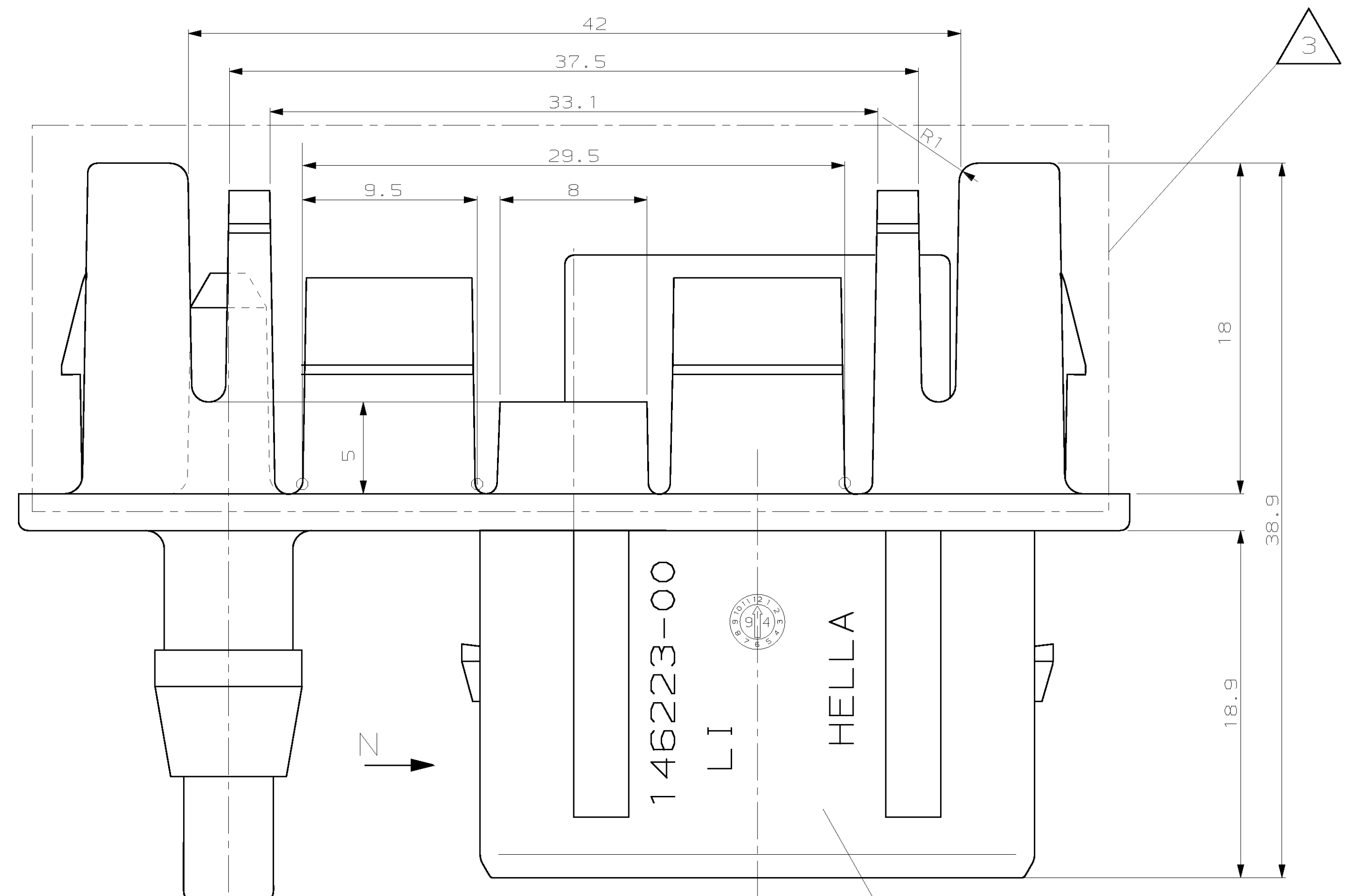
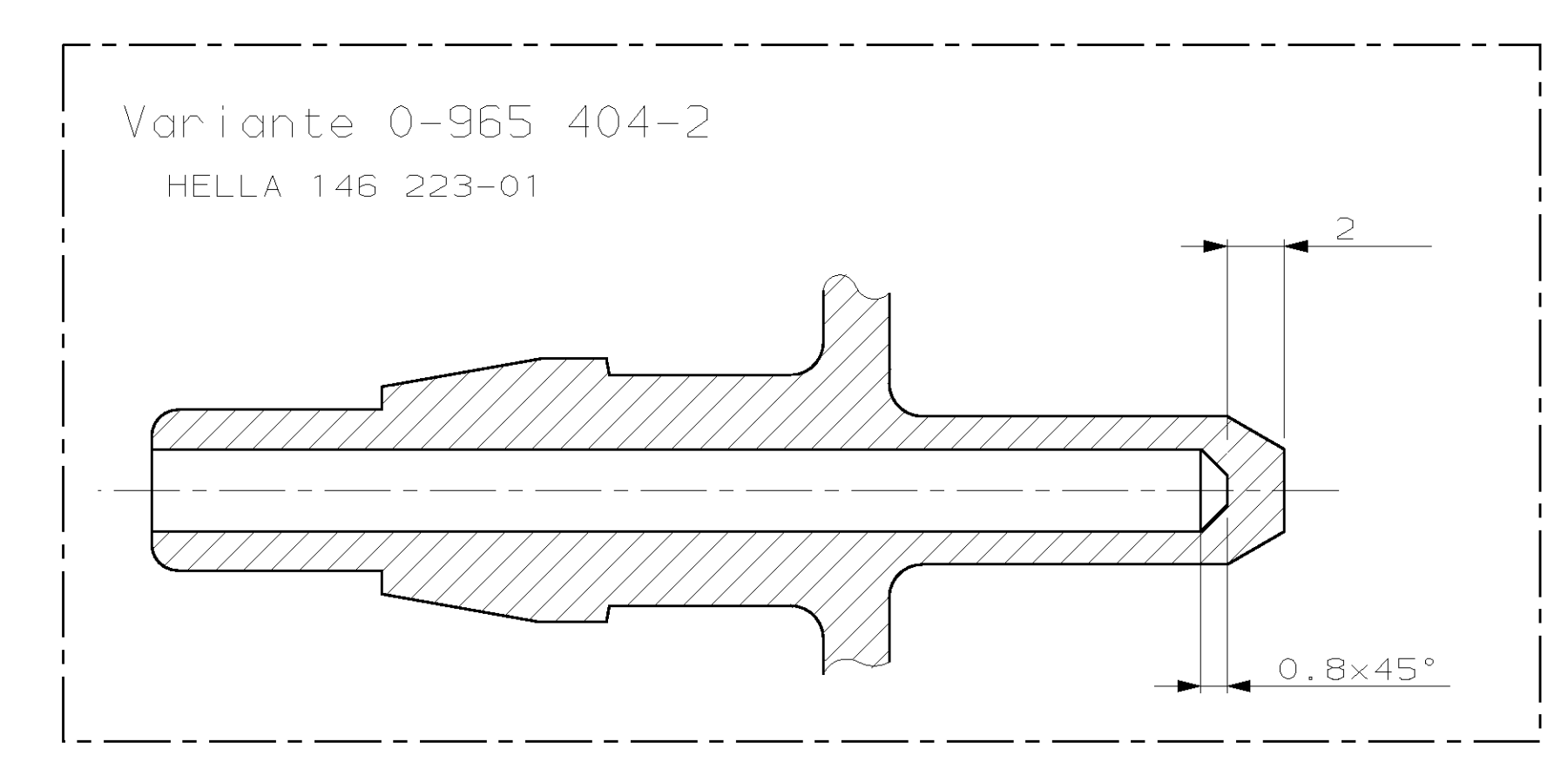
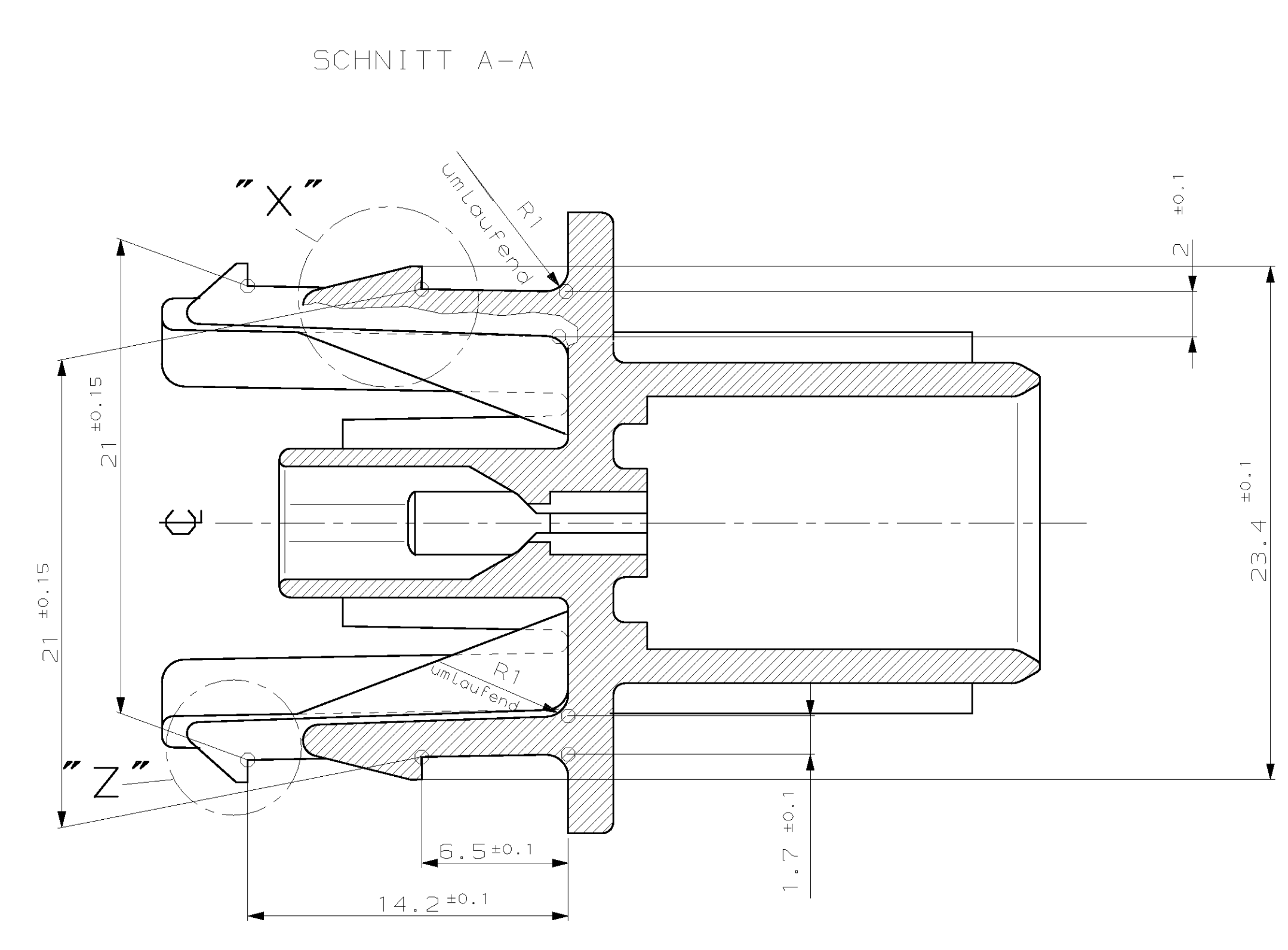
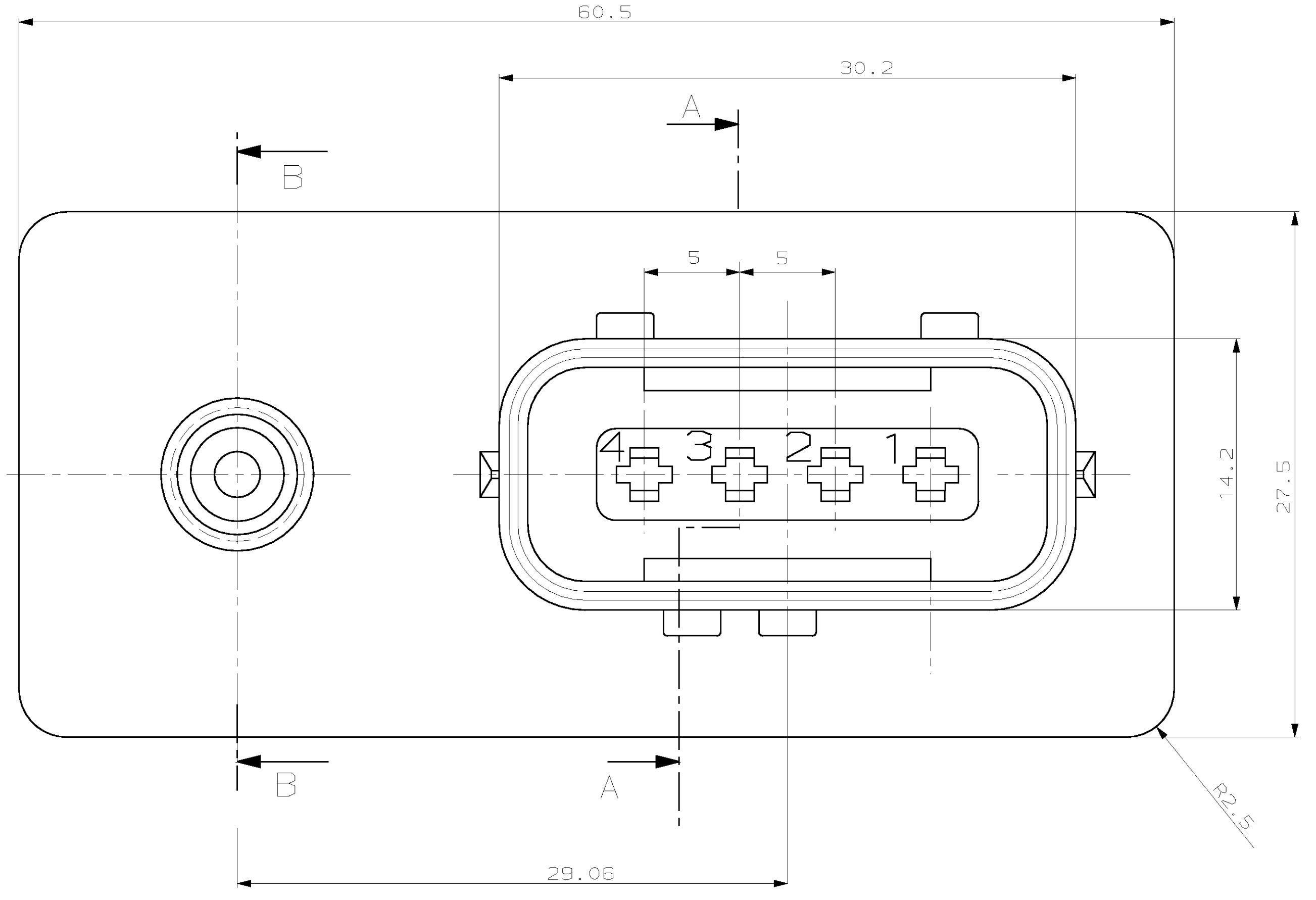

Einzelheit "X"
DETAIL "X"

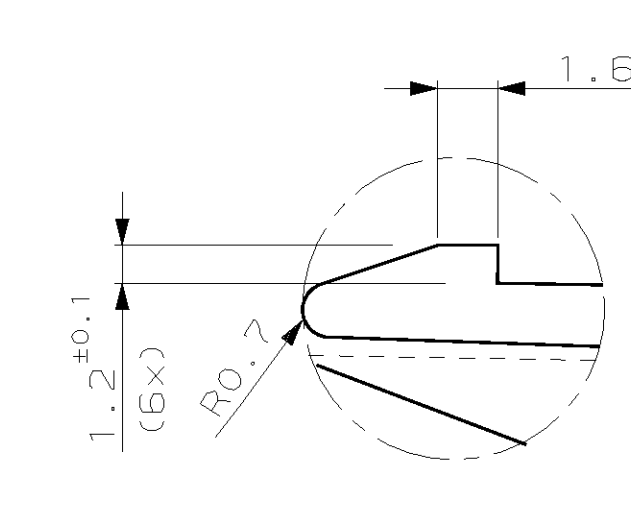

Einzelheit "Z"
DETAIL "Z" (4x)

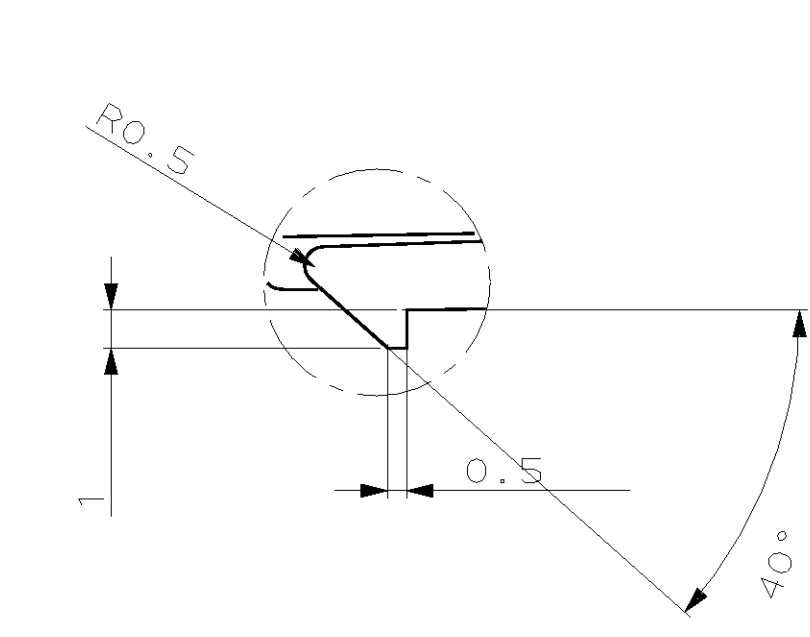

Bemerkungen

- 1 unbemaßte Radien R0.5
- 2 Kontakt: 2.8mm Fastin Faston
928 930; 927 893; 928 781
- 3 Auszugsschrägen in diesem Bereich 1°

Steckeranschluß gem. AMP J-P-T
(passend zu Gegenstecker AMP 967264)
Ausführungsvorschrift MB 210 001 49 99

ZEICHNUNG GÜLTIG AB						AMP DEUTSCHLAND GmbH D-63225 Langen	
146223-01	0-965404-2	A	1	Steckergehäuse	PA6.6-GF 13	natur	4pol. FF Steckergehäuse LI mit pneum. Anschluß
146223-00	0-965404-1	A	1	Steckergehäuse	PA6.6-GF 13	schwarz	
HELLA NR.	BESTELL-NR.	KODIERUNG	STÜCK	BENENNUNG EINZELTEIL	WERKSTOFF	OBERFLÄCHE FARBE	ZEICHNUNG-NR.
							965404
M. WALDMANN						E. DOERR	
17.01.1994						12.01.1994	
1						1	

THIS INFORMATION IS CONFIDENTIAL AND IS DISCLOSED TO YOU ON CONDITION THAT NO FURTHER DISCLOSURE IS MADE BY YOU TO OTHER THAN AMP PERSONNEL WITHOUT WRITTEN AUTHORIZATION FROM AMP ELECTRONICS GERMANY.