



Chipsmall Limited consists of a professional team with an average of over 10 year of expertise in the distribution of electronic components. Based in Hongkong, we have already established firm and mutual-benefit business relationships with customers from,Europe,America and south Asia,supplying obsolete and hard-to-find components to meet their specific needs.

With the principle of “Quality Parts,Customers Priority,Honest Operation,and Considerate Service”,our business mainly focus on the distribution of electronic components. Line cards we deal with include Microchip,ALPS,ROHM,Xilinx,Pulse,ON,Everlight and Freescale. Main products comprise IC,Modules,Potentiometer,IC Socket,Relay,Connector.Our parts cover such applications as commercial,industrial, and automotives areas.

We are looking forward to setting up business relationship with you and hope to provide you with the best service and solution. Let us make a better world for our industry!



Contact us

Tel: +86-755-8981 8866 Fax: +86-755-8427 6832

Email & Skype: info@chipsmall.com Web: www.chipsmall.com

Address: A1208, Overseas Decoration Building, #122 Zhenhua RD., Futian, Shenzhen, China



NICHT VERMASSTE KANTEN SIND NICHT MAßSTÄBLICH

ÄNDERUNGEN DIE DEM TECHNISCHEN FORTSCHRITT DIENEN, BEHALTEN WIR UNS VOR

ZEICHNUNG GESCHÜTZT DURCH © COPYRIGHT 1994 AMP DEUTSCHLAND GMBH ALLE RECHTE VORBEHALTEN

REV.	ÄNDERUNG	DATUM	NAME
B	2 Prägungen hinzu, Darstellung der Feder geändert	14.07.94	Wittig
C	Federschlitzbreite von 0.8 auf 0.9 geändert	25.07.94	Wittig
C1	div. Änderungen	03.02.95	Wittig

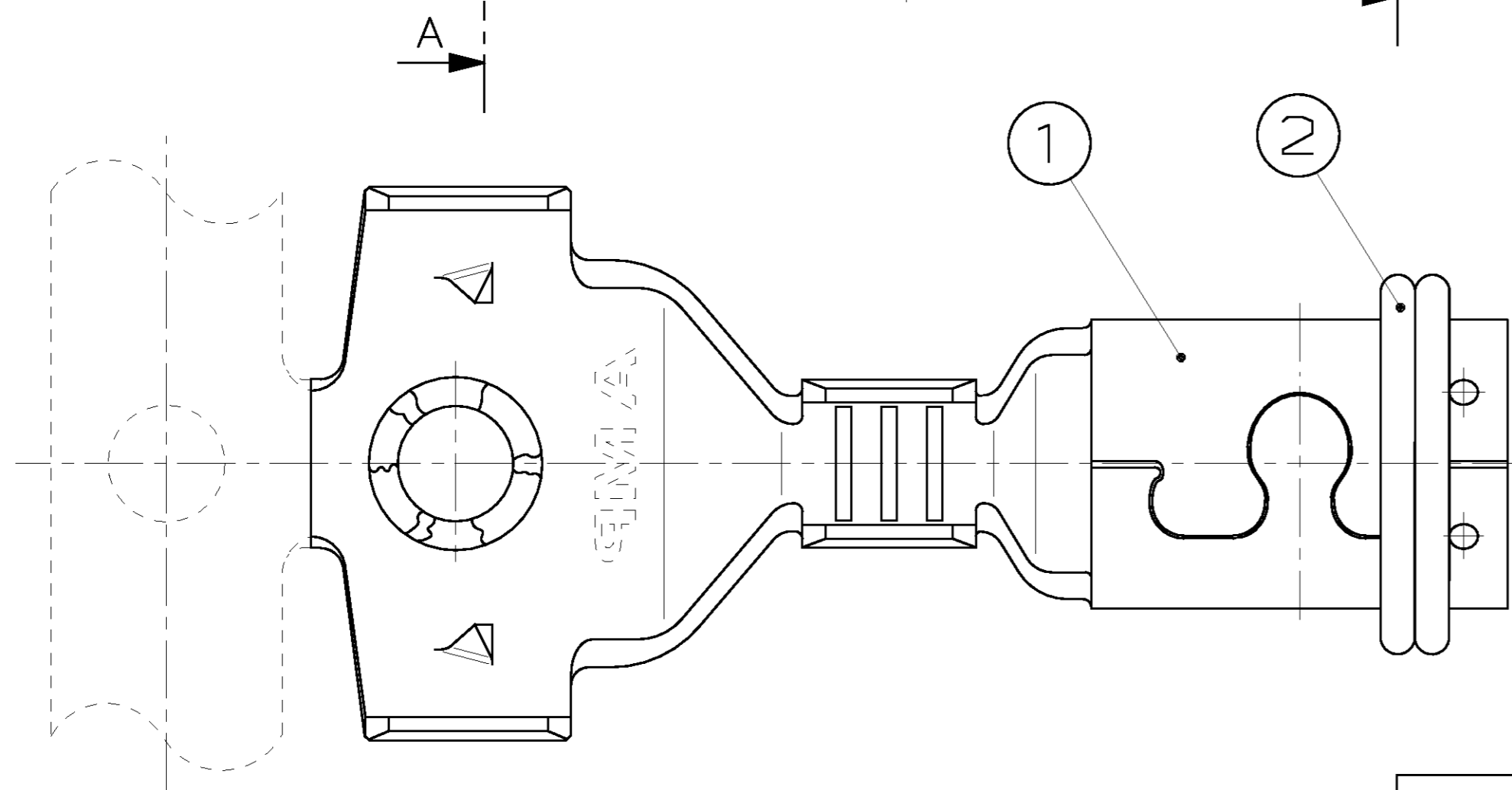
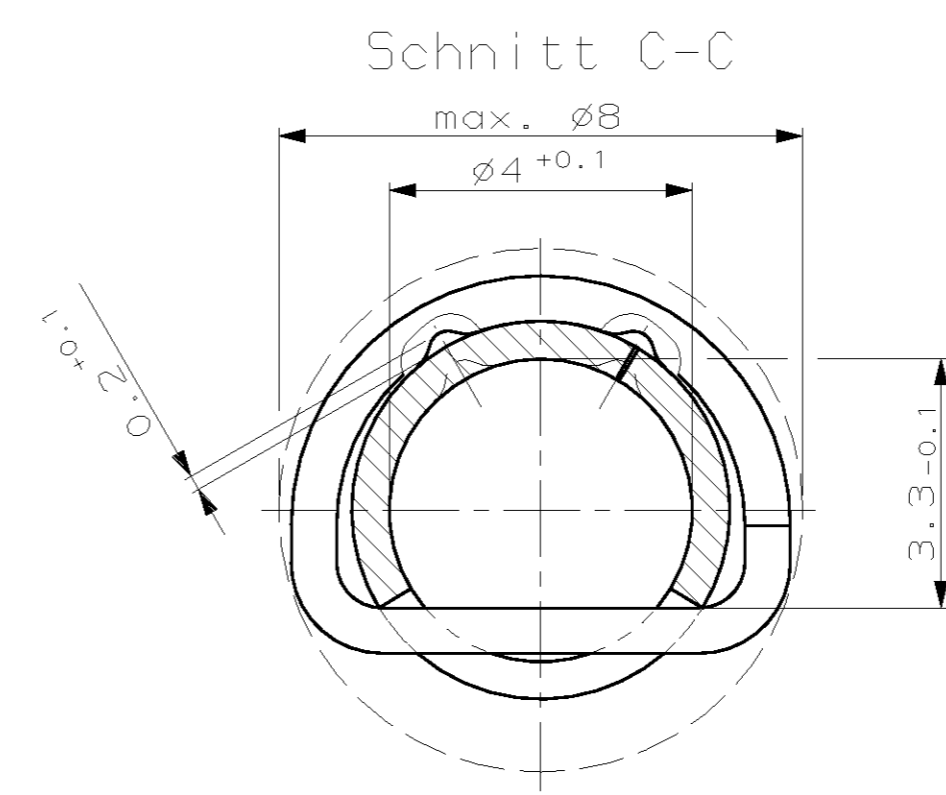
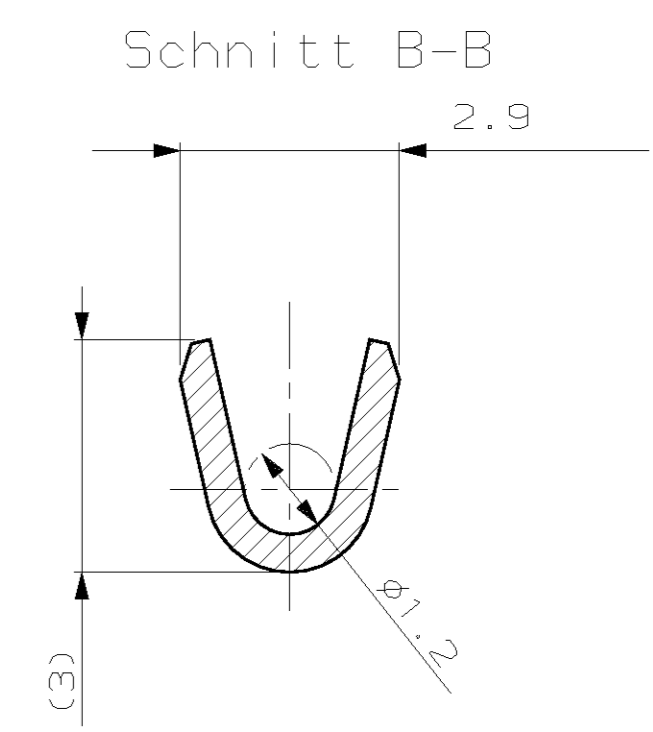
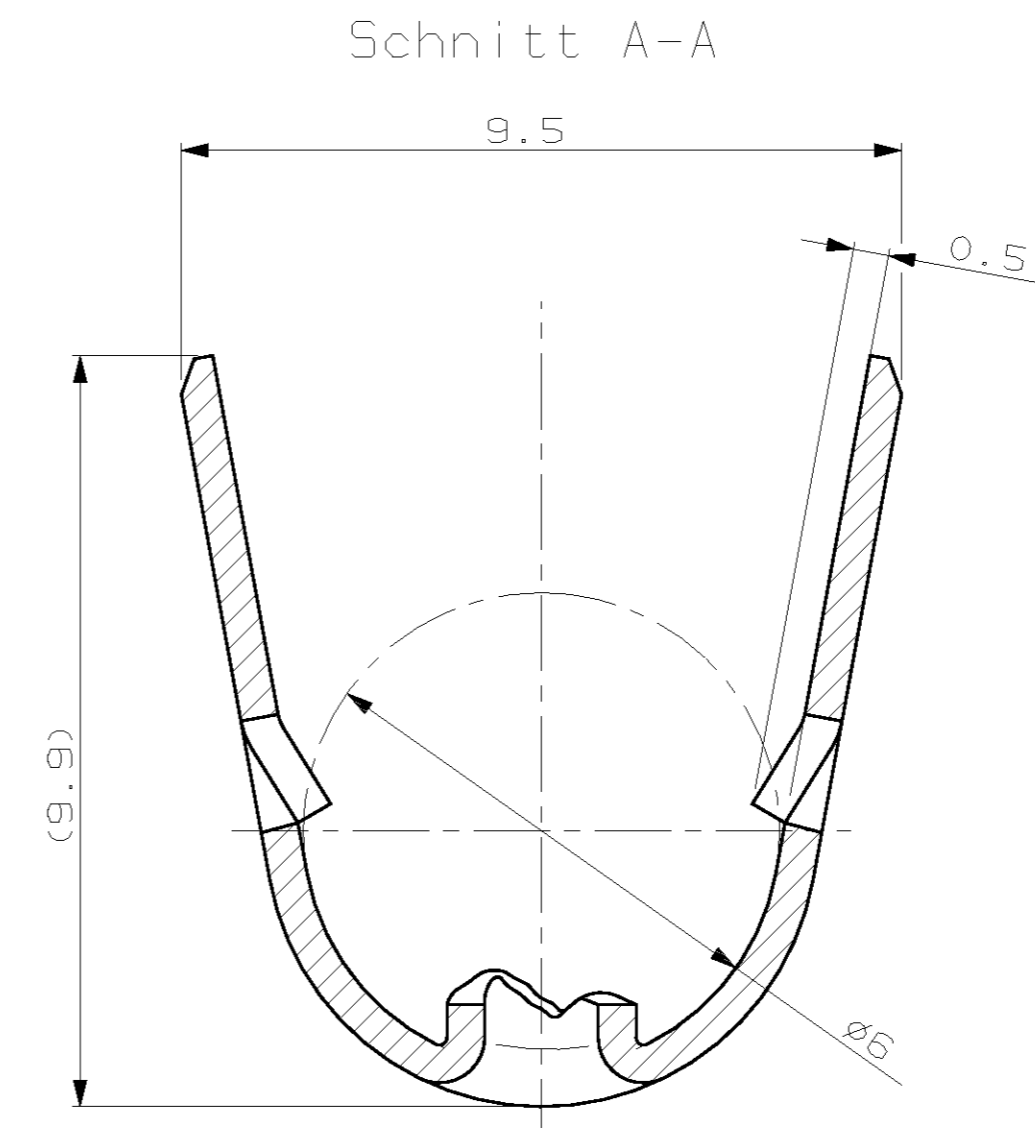
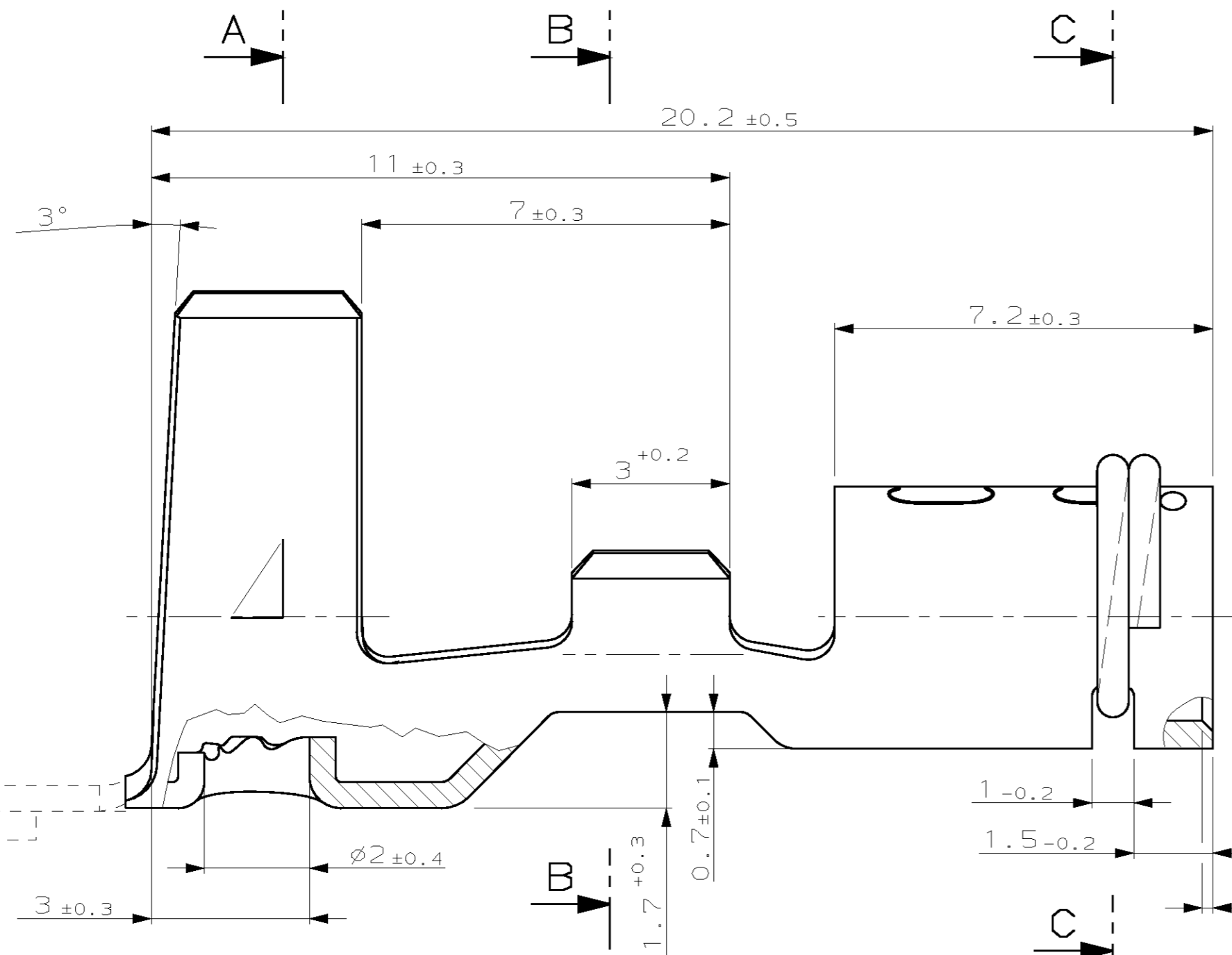

Steck- und Ziehkräfte

	Steckkraft	Abziehkraft	Nr. der Prüflöhre
Lösbare Variante	max. 50 N (1. Steckung)	40 N - 60 N (10. Steckung)	BOSCH-NR. Y356H00060 (AMP-NR. 90-244547)
unlösbare Variante	max. 50 N (1. Steckung)	>180 N (1. Steckung)	BOSCH-NR. Y356H00061 (AMP-NR. 90-244548)

Prüfgeschwindigkeit: v=50 mm/min (bei 20°C)

BESTELL-NR.	POS.	STÜCK	BENENNUNG EINZELTEIL	WERKSTOFF	OBERFLÄCHE
968004-1	2	1	Ringfeder Ø0.6	Edelstahl	blank
	1	1	Kontakt	Cu5n4	blank
GEZ. L. WITTIG			07 JUN 1994		GEPR. -

ZEICHNUNG GÜLTIG AB		
AMP AMP DEUTSCHLAND G.m.b.H. Langen b.Ffm., Germany		
BENENNUNG		K
Zündkabelkontakt mit Ringfeder		
NICHT TOLERIERTE MASSE ± 0.2 mm ± 2°	FORMAT A2	ZEICHNUNGS-NR. 968004
MASSTAB 10:1	BLATT 1 VON 1	REV. C1

968004
NUMMER
VERWENDET FÜR
PASSEND ZU
CAD-ORIGINAL
ZEICHNUNG NICHT ÄNDERN
WAR NR. 93-52274-100