



Chipsmall Limited consists of a professional team with an average of over 10 year of expertise in the distribution of electronic components. Based in Hongkong, we have already established firm and mutual-benefit business relationships with customers from,Europe,America and south Asia,supplying obsolete and hard-to-find components to meet their specific needs.

With the principle of “Quality Parts,Customers Priority,Honest Operation,and Considerate Service”,our business mainly focus on the distribution of electronic components. Line cards we deal with include Microchip,ALPS,ROHM,Xilinx,Pulse,ON,Everlight and Freescale. Main products comprise IC,Modules,Potentiometer,IC Socket,Relay,Connector.Our parts cover such applications as commercial,industrial, and automotives areas.

We are looking forward to setting up business relationship with you and hope to provide you with the best service and solution. Let us make a better world for our industry!



Contact us

Tel: +86-755-8981 8866 Fax: +86-755-8427 6832

Email & Skype: info@chipsmall.com Web: www.chipsmall.com

Address: A1208, Overseas Decoration Building, #122 Zhenhua RD., Futian, Shenzhen, China



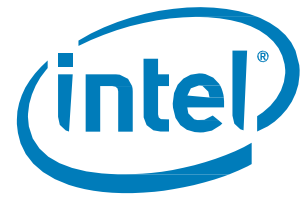

Intel® Solid State Drive DC S3520 Series

Product Specification

- **Capacity:**
 - 2.5": 240GB, 480GB, 800GB, 960GB, 1.2TB, 1.6TB
 - M.2: 240GB, 480GB, 760GB, 960GB
- **Components:**
 - 3D MLC NAND Flash Memory
 - Standard Endurance Technology (SET)
- **Form Factor:** 2.5-inch, M.2
- **Read and Write IOPS^{1,2}**
(Full LBA Range, IOMeter* Queue Depth 32)
 - Random 4KB³ Reads: Up to 67,500 IOPS
 - Random 4KB Writes: Up to 17,500 IOPS
 - Random 8KB³ Reads: Up to 45,000 IOPS
 - Random 8KB Writes: Up to 9,500 IOPS
- **Bandwidth Performance¹**
 - Sustained Sequential Read: Up to 450 MB/s⁴
 - Sustained Sequential Write: Up to 380 MB/s
- **Endurance:**
 - Up to 2925 TBW (Terabytes Written)
 - Up to 1 drive writes per day⁵ for 5 years
 - Up to 1.6 drive writes per day⁵ for 3 years
- **Latency (average sequential)**
 - Read: 2.5" - 40 µs (TYP); M.2 - 46 µs (TYP)
 - Write: 2.5" - 42 µs (TYP); M.2 - 50 µs (TYP)
- **Quality of Service^{6,8}**
 - Read/Write: 2.5" - 3 ms / <1.5 ms (99.9%); M.2 - TBD
- **Performance Consistency^{7,8}**
 - Read/Write: Up to 98%/85% (99.9%)
- **Self-Encrypting Drive (SED)**
 - AES 256-bit encryption
- **Altitude⁹**
 - Operating: -1,000 to 10,000 ft
 - Operating¹⁰: 10,000 to 15,000 ft
 - Non-operating: -1,000 to 40,000 ft
- **Product Ecological Compliance**
 - RoHS*
- **Compliance**
 - SATA Revision 3.2; compatible with SATA 6Gb/s, 3Gb/s and 1.5Gb/s interface rates
 - ATA/ATAPI Command Set – 3 (ACS-3 Rev 5); includes SCT (Smart Command Transport) and device statistics log support
 - Enhanced SMART ATA feature set
 - Native Command Queuing (NCQ) command set
 - Data set management Trim command
- **Power Management**
 - 2.5" - 5V or 5V+12V SATA Supply Rail¹¹
 - M.2 - 3.3V only
 - SATA Interface Power Management
 - OS-aware hot plug/removal
 - Enhanced power-loss data protection feature
- **Power¹²**
 - Active: Up to 3.5 W⁸ (TYP)
 - Idle: 2.5" - 600 mW; M.2 - 700 mW
- **Weight:**
 - 2.5"
 - 240GB, 480GB: 62 grams ± 2 grams
 - 800GB: 63 grams ± 2 grams
 - 960GB, 1.2TB, 1.6TB: 66 grams ± 2 grams
 - M.2
 - 240GB, 480GB, 760GB, 960GB: 9 grams ± 1 gram
- **Temperature**
 - Operating: 0° C to 70° C
 - Non-Operating¹³: -55° C to 95° C
 - Temperature monitoring and logging
 - Thermal throttling when approaching maximum operating temperature
- **Shock (operating and non-operating):**
 - 1,000 G / 0.5 ms
- **Vibration**
 - Operating: 2.17 G_{RMS} (5-700 Hz)
 - Non-Operating: 3.13 G_{RMS} (5-800 Hz)
- **Reliability**
 - Uncorrectable Bit Error Rate (UBER): 1 sector per 10¹⁷ bits read
 - Mean Time Between Failures (MTBF): 2 million hours
 - End-to-End data protection
- **Certifications and Declarations**
 - UL*, CE*, C-Tick*, BSMI*, KCC*, Microsoft* WHCK, VCCI*, SATA-IO*
- **Compatibility**
 - Windows 8*, Windows 8.1*, Windows 10*
 - Windows Server 2012*, 2012 R2*
 - Windows Server 2008* Enterprise 32/64bit SP2
 - Windows Server 2008* R2
 - VMWare* 5.1, 5.5
 - Red Hat* Enterprise Linux* 6.3, 6.5, 7.0
 - SUSE* Linux* Enterprise Server 11 SP1, SP3
 - CentOS* 64bit 6.3, 6.5
 - VMWare* 6.0, 6.5
 - Intel® SSD Toolbox with Intel® SSD Optimizer

1. Performance values vary by capacity

2. Performance specifications apply to both compressible and incompressible data

3. 4KB = 4,096 bytes; 8KB = 8,192 bytes.

4. MB/s = 1,000,000 bytes/second

5. Based on JESD218 standard.

6. Based on Random 4KB QD=1 workload, measured as the time taken for 99.9 percentile of commands to finish the round-trip from host to drive and back to host

7. Based on Random 4KB QD=32 workload, measured as the (IOPS in the 99.9th percentile slowest 1-second interval)/(average IOPS during the test)

8. Measurement taken once the workload has reached steady state but including all background activities required for normal operation and data reliability

9. Altitude pressure is simulated in a test chamber; excludes soft error

10. Extended operation at a higher altitude might impact reliability.

11. If both 12V and 5V power supplies are present, defaults to 5V+ 12V power supplies. Does not support 12 volt only.

12. Based on 5V power supply

13. Please contact your Intel representative for details on the non-operating temperature range



Ordering Information

Contact your local Intel sales representative for ordering information.

Revision History

Revision	Description	Date
001	Initial release	August 2016

Related Document

Document Name	Date
Intel® SSD DC S3520 Series 150GB Product Specification	August 2016

Intel may make changes to specifications and product descriptions at any time, without notice. Designers must not rely on the absence or characteristics of any features or instructions marked "reserved" or "undefined." Intel reserves these for future definition and shall have no responsibility whatsoever for conflicts or incompatibilities arising from future changes to them. The information here is subject to change without notice. Do not finalize a design with this information.

Tests document performance of components on a particular test, in specific systems. Differences in hardware, software, or configuration will affect actual performance. Consult other sources of information to evaluate performance as you consider your purchase.

System Configuration for all performance testing: Intel® Xeon® CPU E5-2699v3 @ 2.30GHz on Intel® S2600WT2 motherboard, Intel® C612 Chipset (Intel® DH82029 PCH), BIOS Version SE5C610.86B.01.01.0014.121820151719 32GB DDR4, CentOS* 7, Kernel 4.3.3, FIO* 2.8, Intel® SSD DC S3520 FW N2010018

All documented endurance test results are obtained in compliance with JESD218 Standards; refer to individual sub-sections within this document for specific methodologies. See www.jedec.org for detailed definitions of JESD218 Standards.

The products described in this document may contain design defects or errors known as errata which may cause the product to deviate from published specifications. Current characterized errata are available on request.

Contact your local Intel sales office or your distributor to obtain the latest specifications and before placing your product order.

Intel and the Intel logo are trademarks of Intel Corporation in the U.S. and other countries.

*Other names and brands may be claimed as the property of others.

Copyright © 2016 Intel Corporation. All rights reserved.



Contents

	Ordering Information	2
	Revision History	2
	Related Document	2
	Terminology	5
1	Overview.....	6
2	Product Specifications	7
2.1	Capacity.....	7
2.2	Performance.....	7
2.3	Electrical Characteristics	12
2.4	Environmental Conditions.....	14
2.5	Product Regulatory Compliance.....	15
2.6	Reliability	15
2.7	Temperature Sensor	17
2.8	Power Loss Capacitor Test.....	17
2.9	Hot Plug Support	17
2.10	Self-Encrypting Drive (SED)	17
3	Mechanical Information	18
4	Pin and Signal Descriptions	20
4.1	2.5-inch Form Factor Pin Locations	20
4.2	Connector Pin Signal Definitions.....	20
4.3	Power Pin Signal Definitions.....	21
5	Supported Command Sets	23
5.1	ATA General Feature Command Set.....	23
5.2	Power Management Command Set.....	23
5.3	Security Mode Feature Set	24
5.4	SMART Command Set	24
5.5	Device Statistics.....	30
5.6	SMART Command Transport (SCT).....	32
5.7	Data Set Management Command Set.....	32
5.8	Accessible Max Address Configuration Command Set.....	32
5.9	48-Bit Address Command Set.....	33
5.10	General Purpose Log Command Set.....	33
5.11	Native Command Queuing	33
5.12	Software Settings Preservation.....	33
6	Certifications and Declarations	34
7	References	35
	Appendix A: IDENTIFY DEVICE Command Data.....	36



Figures

Figure 1: Intel SSD DC S3520 Series 2.5-inch Dimensions	18
Figure 2: Intel SSD DC S3520 Series M.2 Dimensions.....	19
Figure 3: Layout of 2.5-inch Form Factor Signal and Power Segment Pins.....	20

Tables

Table 2: User-Addressable Sectors	7
Table 3: 2.5 Inch Random Read/Write Input/Output Operations Per Second (IOPS).....	7
Table 4: M.2 Random Read/Write Input/Output Operations Per Second (IOPS).....	8
Table 5: 2.5-Inch Random Read/Write IOPS Consistency	9
Table 6: M.2 Random Read/Write IOPS Consistency	9
Table 7: 2.5-Inch Sequential Read and Write Bandwidth.....	9
Table 8: M.2 Sequential Read and Write Bandwidth	10
Table 9: 2.5-Inch and M.2 Latency	10
Table 10: 2.5-inch and M.2 Power On to Ready	10
Table 11: Quality of Service for 2.5-inch Form Factor.....	11
Table 12: Quality of Service for M.2 Form Factor	11
Table 13: Operating Voltage for 2.5-inch Form Factor	12
Table 14: Operating Voltage for M.2 Form Factor.....	12
Table 15: Power Consumption for 2.5-inch Form Factor (5V Supply).....	13
Table 16: Power Consumption for 2.5-inch Form Factor (5V + 12V Supply)	13
Table 17: Power Consumption for M.2 Form Factor	14
Table 18: Temperature, Shock, Vibration.....	14
Table 19: Product Regulatory Compliance Specifications.....	15
Table 20: Reliability Specifications	15
Table 21: Endurance Rating.....	16
Table 22: Serial ATA Connector Pin Signal Definitions—2.5-inch Form Factors.....	20
Table 23: Serial ATA Power Pin Definitions—2.5-inch Form Factors.....	21
Table 24: Serial ATA Power Pin Definitions—M.2-inch Form Factors.....	21
Table 25: SMART Attributes.....	24
Table 26: SMART Attribute Status Flags	27
Table 27: Device Statistics	31
Table 28: Device Certifications and Declarations	34
Table 29: Standards References	35
Table 30: Returned Sector Data	36



Terminology

Term	Definition
ATA	Advanced Technology Attachment
CRC	Cyclic Redundancy Check
DAS	Device Activity Signal
DMA	Direct Memory Access
ECC	Error Correction Code
EXT	Extended
FPDMA	First Party Direct Memory Access
GB	Gigabyte. Note: The total usable capacity of the SSD may be less than the total physical capacity because a small portion of the capacity is used for NAND flash management and maintenance purposes.
Gb	Gigabit
HDD	Hard Disk Drive
HET	High Endurance Technology
KB	Kilobyte
I/O	Input/Output
IOPS	Input/Output Operations Per Second
ISO	International Standards Organization
LBA	Logical Block Address
MB	Megabyte (1,000,000 bytes)
MLC	Multi-level Cell
MTBF	Mean Time Between Failures
NCQ	Native Command Queuing
NOP	No Operation
PB	Petabyte
PCB	Printed Circuit Board
PIO	Programmed Input/Output
RDT	Reliability Demonstration Test
RMS	Root Mean Square
SATA	Serial Advanced Technology Attachment
SCT	SMART Command Transport
SMART	Self-Monitoring, Analysis and Reporting Technology. This is an open standard for developing hard drives and software systems that automatically monitors the health of a drive and reports potential problems.
SSD	Solid-State Drive
TB	Terabyte
TYP	Typical
UBER	Uncorrectable Bit Error Rate



1 Overview

This document describes the specifications and capabilities of the Intel® SSD DC S3520 Series.

The Intel® SSD DC S3520 Series delivers great performance and Quality of Service combined with high reliability for Serial Advanced Technology Attachment (SATA)-based computers in capacities of 150GB, 240GB, 480GB, 800GB, 960GB, 1.2TB and 1.6TB in a 2.5-inch form factor and 150GB, 240GB, 480GB, 760GB, and 960GB in the M.2 form factor

By combining Intel's 3D MLC NAND Flash Memory technology with SATA 6 GB/s interface support, the Intel SSD DC S3520 Series delivers Sequential Read speeds of up to 450 MB/s and Sequential Write speeds of up to 400 MB/s. The Intel SSD DC S3520 Series also delivers Random 4k Read speeds of up to 67,500 IOPS and Random 4K Write speeds of up to 18,000 IOPS, and Quality of Service of 3 ms for random 4KB reads measured at a queue depth of 1.

The industry-standard 2.5-inch and M.2 form factors enable interchangeability with existing hard disk drives (HDDs) and native SATA HDD drop-in replacement with the enhanced performance, reliability, ruggedness, and power savings offered by an SSD.

Intel SSD DC S3520 Series offers these key features:

- Standard Endurance Technology
- High I/O and throughput performance
- Consistent I/O latency
- Tested and Proven power-loss data protection with self-test
- Proven End-to-End data protection, Demonstrated 10^{-17} UBER
- Thermal throttling
- Temperature Sensor
- Inrush current management
- Low power
- High reliability
- Temperature monitor and logging
- <5% Performance Degradation over product life



2 Product Specifications

2.1 Capacity

Table 1: User-Addressable Sectors

Intel SSD DC S3520 Series	Unformatted Capacity (Total User Addressable Sectors in LBA Mode)
240GB	468,862,128
480GB	937,703,088
760GB	1,484,684,208
800GB	1,562,824,368
960GB	1,875,385,008
1.2TB	2,344,225,968
1.6TB	3,125,627,568

Notes:

1GB = 1,000,000,000 bytes; 1 sector = 512 bytes.

LBA count shown represents total user storage capacity and will remain the same throughout the life of the drive.

The total usable capacity of the SSD may be less than the total physical capacity because a small portion of the capacity is used for NAND flash management and maintenance purposes.

2.2 Performance

Table 2: 2.5 Inch Random Read/Write Input/Output Operations Per Second (IOPS)¹

Specification	Unit	Intel SSD DC S3520 Series					
		240GB	480GB	800GB	960GB	1.2TB	1.6TB
Random 4KB Read (up to) ²	IOPS	65,000	65,500	65,500	67,000	67,500	67,500
Random 4KB Write (up to)	IOPS	16,000	16,000	17,000	16,000	17,500	17,000
Random 8KB Read (up to) ³	IOPS	36,000	45,000	43,000	45,000	45,000	45,000
Random 8KB Write (up to)	IOPS	8,000	8,000	9,500	8,000	8,500	8,500
Random 4KB 70/30 Read/Write (up to) ²	IOPS	24,000	26,000	31,500	30,000	33,000	33,000
Random 8KB 70/30 Read/Write (up to) ³	IOPS	13,500	15,000	18,500	17,500	19,000	19,000

Notes:

- Performance measured using FIO* on Linux* with Queue Depth 32. Measurements are performed on a full Logical Block Address (LBA) span of the drive. Performance with different Queue Depths will be provided upon request
- 4KB = 4,096 bytes
- 8KB = 8,192 bytes



Table 3: M.2 Random Read/Write Input/Output Operations Per Second (IOPS)^{1,2}

Specification	Unit	Intel SSD DC S3520 Series			
		240GB	480GB	760GB	960GB
Random 4KB Read (up to) ³	IOPS	50,000	52,500	52,800	53,000
Random 4KB Write (up to)	IOPS	14,400	14,400	14,400	14,400
Random 8KB Read (up to) ⁴	IOPS	34,700	37,300	37,600	38,000
Random 8KB Write (up to)	IOPS	7,300	7,300	7,300	7,300
Random 4KB 70/30 Read/Write (up to) ³	IOPS	22,000	24,000	24,000	24,300
Random 8KB 70/30 Read/Write (up to) ⁴	IOPS	12,500	14,000	14,000	14,200

Notes:

1. All values in this table are preliminary and will be updated with production M.2.
2. Performance measured using FIO* on Linux* with Queue Depth 32. Measurements are performed on a full Logical Block Address (LBA) span of the drive. Performance with different Queue Depths will be provided upon request.
3. 4KB = 4,096 bytes
4. 8KB = 8,192 bytes

Table 4: 2.5-Inch Random Read/Write IOPS Consistency¹

Specification	Unit	Intel SSD DC S3520 Series					
		240GB	480GB	800GB	960GB	1.2TB	1.6TB
Random 4KB Read (up to) ²	%	98	98	98	98	98	98
Random 4KB Write (up to)	%	85	85	85	85	85	85
Random 8KB Read (up to) ³	%	98	98	98	98	98	98
Random 8KB Write (up to)	%	85	85	85	85	85	85

Notes:

1. Performance consistency measured using FIO* on Linux* based on Random 4KB QD=32 workload, measured as the (IOPS in the 99.9th percentile slowest 1-second interval) / (average IOPS during the test). Measurements are performed on a full Logical Block Address (LBA) span of the drive once the workload has reached steady state but including all background activities required for normal operation and data reliability
2. 4KB = 4,096 bytes
3. 8KB = 8,192 bytes

Table 5: M.2 Random Read/Write IOPS Consistency^{1,2}

Specification	Unit	Intel SSD DC S3520 Series			
		240GB	480GB	760GB	960GB
Random 4KB Read (up to) ³	%	98	99	99	99
Random 4KB Write (up to)	%	90	90	90	90
Random 8KB Read (up to) ⁴	%	97	97	97	97
Random 8KB Write (up to)	%	87	87	87	87

Notes:

1. All values in this table are preliminary and will be updated with production M.2.
2. Performance consistency measured using IOMeter* based on Random 4KB QD=32 workload, measured as the (IOPS in the 99.9th percentile slowest 1-second interval) / (average IOPS during the test). Measurements are performed on a full Logical Block Address (LBA) span of the drive once the workload has reached steady state but including all background activities required for normal operation and data reliability.
3. 4KB = 4,096 bytes
4. 8KB = 8,192 bytes

Table 6: 2.5-Inch Sequential Read and Write Bandwidth¹

Specification	Unit	Intel SSD DC S3520 Series					
		240GB	480GB	800GB	960GB	1.2TB	1.6TB
Sequential Read (SATA 6Gb/s) ¹	MB/s	320	450	450	450	450	450
Sequential Write (SATA 6Gb/s) ¹	MB/s	300	380	380	380	380	380

Note:

1. Performance measured using FIO* on Linux* with 128KB (131,072 bytes) of transfer size with Queue Depth 32.



Table 7: M.2 Sequential Read and Write Bandwidth¹

Specification	Unit	Intel SSD DC S3520 Series			
		240GB	480GB	760GB	960GB
Sequential Read (SATA 6Gb/s) ¹	MB/s	320	410	410	410
Sequential Write (SATA 6Gb/s) ¹	MB/s	260	320	320	320

Note:

1. All values in this table are preliminary and will be updated with production M.2.
2. Performance measured using FIO* on Linux* with 128KB (131,072 bytes) of transfer size with Queue Depth 32.

Table 8: 2.5-Inch and M.2 Latency

Specification	Intel SSD DC S3520 Series	
	2.5"	M.2
	240GB, 480GB, 800GB, 900GB, 1.2TB, 1.6TB	240GB, 480GB, 760GB, 960GB
Latency (TYP) ¹		
Read Sequential/Random	40/160 μs	TBD
Write Sequential/Random	42/75 μs	TBD

Note:

1. Device measured using FIO* on Linux*. Latency measured using 4KB (4,096 bytes) transfer size with Queue Depth equal to 1 on a sequential and random workload.

Table 9: 2.5-inch and M.2 Power On to Ready

Specification	Intel SSD DC S3520 Series	
	2.5" & M.2	
	240GB, 480GB	760GB, 800GB, 960GB, 1.2TB, 1.6TB
Power On to Ready ¹	5 s	10 s

Note:

1. Power On To Ready time assumes proper shutdown. Time varies if shutdown is not preceded by STANDBY IMMEDIATE command.



Table 10: Quality of Service for 2.5-inch Form Factor

Specification	Unit	Intel 2.5-inch SSD DC S3520 Series					
		240GB	480GB	800GB	960GB	1.2TB	1.6TB
Quality of Service^{1,2} (99.9%)							
Reads Queue Depth 1	ms	0.25	0.25	0.25	0.25	0.25	0.25
Reads Queue Depth 32	ms	1.5	1.5	1.5	1.5	1.5	1.5
Writes Queue Depth 1	ms	1.5	1.5	1.5	0.8	0.8	0.8
Writes Queue Depth 32	ms	11	9	7	7	6	6
Quality of Service^{1,2} (99.9999%)							
Reads Queue Depth 1	ms	8	8	8	8	8	8
Reads Queue Depth 32	ms	10	10	10	10	10	10
Writes Queue Depth 1	ms	13	13	13	13	20	25
Writes Queue Depth 32	ms	30	30	30	30	35	45

Notes:

1. Device measured using FIO* on Linux*. Quality of Service measured using 4KB (4,096 bytes) transfer size on a random workload on a full Logical Block Address (LBA) span of the drive once the workload has reached steady state but including all background activities required for normal operation and data reliability.
2. Based on Random 4KB QD=1, 32 workloads, measured as the time taken for 99.9(or 99.9999) percentile of commands to finish the round-trip from host to drive and back to host.

Table 11: Quality of Service for M.2 Form Factor^{1,2}

Specification	Unit	Intel SSD DC S3520 Series			
		240GB	480GB	760GB	960GB
Quality of Service^{2,3} (99.9%)					
Reads Queue Depth 1	ms	TBD	TBD	TBD	TBD
Reads Queue Depth 32	ms	TBD	TBD	TBD	TBD
Writes Queue Depth 1	us	TBD	TBD	TBD	TBD
Writes Queue Depth 32	ms	TBD	TBD	TBD	TBD
Quality of Service^{2,3} (99.9999%)					
Reads Queue Depth 1	ms	TBD	TBD	TBD	TBD
Reads Queue Depth 32	ms	TBD	TBD	TBD	TBD
Writes Queue Depth 1	ms	TBD	TBD	TBD	TBD
Writes Queue Depth 32	ms	TBD	TBD	TBD	TBD

Notes:

1. All values will be updated with production M.2.
2. Device measured using FIO* on Linux*. Quality of Service measured using 4KB (4,096 bytes) transfer size on a random workload on a full Logical Block Address (LBA) span of the drive once the workload has reached steady state but including all background activities required for normal operation and data reliability.
3. Based on Random 4KB QD=1, 32 workloads, measured as the time taken for 99.9(or 99.9999) percentile of commands to finish the round-trip from host to drive and back to host.



2.3 Electrical Characteristics

Table 12: Operating Voltage for 2.5-inch Form Factor

Electrical Characteristics	Intel SSD DC S3520 Series
	240GB, 480GB, 800GB, 960GB, 1.2TB, 1.6TB
5 V Operating Characteristics:	
Operating Voltage range	5 V (±5%)
Rise time (Max/Min)	1 s / 1 ms
Fall time (Min) ¹	5 kV/s
Noise level	500 mV pp 10 Hz – 100 KHz 50 mV pp 100 KHz – 20 MHz
Min Off time ²	500 ms
Inrush Current (Typical Peak) ³	1.5 A, < 1 s
12 V Operating Characteristics:	
Operating Voltage range	12 V (±10%)
Rise time (Max/Min)	1 s / 1 ms
Fall time (Min) ¹	12 kV/s
Noise level	1000 mV pp 10 Hz – 100 KHz 100 mV pp 100 KHz – 20 MHz
Min Off time ²	500 ms
Inrush Current (Typical Peak) ³	1.5 A, < 1 s

Notes:

1. Fall time must be equal or better than minimum in order to guarantee full functionality of enhanced power loss management.
2. The drive must be powered off for at least 500msec before powering on.
3. Measured from initial device power supply application.

Table 13: Operating Voltage for M.2 Form Factor

Electrical Characteristics	Intel SSD DC S3520 Series
	240GB, 480GB, 760GB, 960GB
Operating Voltage range	3.3 V (±5%)
Rise time (Max/Min)	100 ms / 1 ms
Fall time (Min) ¹	3.3 kV/s
Noise level	100 mV pp 10 Hz – 20 MHz
Min Off time ²	500 ms
Inrush Current (Typical Peak) ³	1.5 A, < 1 s

Notes:

1. Fall time must be equal or better than minimum in order to guarantee full functionality of enhanced power loss management.
2. The drive must be powered off for at least 500msec before powering on.
3. Measured from initial device power supply application.



Table 14: Power Consumption for 2.5-inch Form Factor (5V Supply)

Specification	Unit	Intel SSD DC S3520 Series					
		240GB	480GB	800GB	960GB	1.2TB	1.6TB
Active Write - RMS Average ¹	W	2.8	3.2	3.5	3.5	3.5	3.5
Active Write - Burst ²	W	4.3	5.8	9.6	9.6	9.6	9.6
Active Read - RMS Average ³	W	2.4	2.9	2.9	3.1	3.1	3.1
Active Read - Burst ⁴	W	3.8	4.7	5	5	5	5
Idle	W	0.5	0.5	0.6	0.6	0.6	0.6

Notes:

1. The workload equates 128 KB (131,072 bytes) Queue Depth equal to 32 sequential writes. RMS (Root Mean Squared) Average Power is measured using Agilent Power Analyzer over a 100 ms sample period.
2. The workload equates 128 KB (131,072 bytes) Queue Depth equal to 32 sequential writes. RMS (Root Mean Squared) Burst Power is measured using Agilent Power Analyzer over a 500 μ s sample period.
3. The workload equates 128 KB (131,072 bytes) Queue Depth equal to 32 sequential reads. RMS (Root Mean Squared) average power is measured using Agilent Power Analyzer over a 100 ms sample period.
4. The workload equates 128 KB (131,072 bytes) Queue Depth equal to 32 sequential reads. RMS (Root Mean Squared) burst power is measured using Agilent Power Analyzer over a 500 μ s sample period.

Table 15: Power Consumption for 2.5-inch Form Factor (5V + 12V Supply)

Specification ¹	Unit	Intel SSD DC S3520 Series											
		240GB		480GB		800GB		960GB		1.2TB		1.6TB	
		5V	12V	5V	12V	5V	12V	5V	12V	5V	12V	5V	12V
Active Write - RMS Average ¹	W	1.6	1.3	1.7	1.55	1.9	1.6	1.9	1.6	1.9	1.6	1.9	1.6
Active Write - Burst ²	W	3.2	2.0	3.2	3.0	3.5	6.3	3.5	7.8	3.5	8.4	3.5	8.4
Active Read - RMS Average ³	W	1.6	0.9	1.7	1.3	1.8	1.3	1.8	1.3	1.9	1.3	1.9	1.3
Active Read - Burst ⁴	W	3	1.2	3.2	1.8	3.5	2.2	3.5	2.2	3.5	2.2	3.5	2.2
Idle	W	0.6	0.04	0.6	0.04	0.6	0.04	0.6	0.07	0.6	0.07	0.6	0.07

Notes:

1. The workload equates 128 KB (131,072 bytes) Queue Depth equal to 32 sequential writes. RMS (Root Mean Squared) Average Power is measured using Agilent Power Analyzer over a 100 ms sample period.
2. The workload equates 128 KB (131,072 bytes) Queue Depth equal to 32 sequential writes. RMS (Root Mean Squared) Burst Power is measured using Agilent Power Analyzer over a 500 μ s sample period.
3. The workload equates 128 KB (131,072 bytes) Queue Depth equal to 32 sequential reads. RMS (Root Mean Squared) average power is measured using Agilent Power Analyzer over a 100 ms sample period.
4. The workload equates 128 KB (131,072 bytes) Queue Depth equal to 32 sequential reads. RMS (Root Mean Squared) burst power is measured using Agilent Power Analyzer over a 500 μ s sample period.



Table 16: Power Consumption for M.2 Form Factor¹

Specification	Unit	Intel SSD DC S3520 Series			
		240GB	480GB	760GB	960GB
Active Write - RMS Average ²	W	TBD	TBD	TBD	TBD
Active Write - Max Burst ³	W	TBD	TBD	TBD	TBD
Active Read - RMS Average ⁴	W	TBD	TBD	TBD	TBD
Active Read - Max Burst ⁵	W	TBD	TBD	TBD	TBD
Idle	W	TBD	TBD	TBD	TBD

Notes:

1. All values will be updated with production M.2.
2. The workload equates 128 KB (131,072 bytes) Queue Depth equal to 32 sequential writes. RMS (Root Mean Squared) Average Power is measured using Agilent Power Analyzer over a 100 ms sample period
3. The workload equates 128 KB (131,072 bytes) Queue Depth equal to 32 sequential writes. RMS (Root Mean Squared) Max Burst power is measured using Agilent Power Analyzer over a 500 μs sample period
4. The workload equates 128 KB (131,072 bytes) Queue Depth equal to 32 sequential reads. RMS (Root Mean Squared) average power is measured using Agilent Power Analyzer over a 100 ms sample period
5. The workload equates 128 KB (131,072 bytes) Queue Depth equal to 32 sequential reads. RMS (Root Mean Squared) Max Burst power is measured using Agilent Power Analyzer over a 500 μs sample period

2.4 Environmental Conditions

Table 17: Temperature, Shock, Vibration

Temperature	Range
Case Temperature Operating Non-operating ¹	0 – 70° C -55 – 95° C
Temperature Gradient ² Operating Non-operating	30° C/hr (Typical) 30° C/hr (Typical)
Humidity Operating Non-operating	5 – 95 % 5 – 95 %
Shock and Vibration	Range
Shock ³ Operating Non-operating	1,000 G (Max) at 0.5 ms 1,000 G (Max) at 0.5 ms
Vibration ⁴ Operating Non-operating	2.17 G _{RMS} (5-700 Hz) Max 3.13 G _{RMS} (5-800 Hz) Max

Notes:

1. Contact your Intel representative for details on the non-operating temperature range.
2. Temperature gradient measured without condensation.
3. Shock specifications assume the SSD is mounted securely with the input vibration applied to the drive-mounting screws. Stimulus may be applied in the X, Y or Z axis. Shock specification is measured using Root Mean Squared (RMS) value.
4. Vibration specifications assume the SSD is mounted securely with the input vibration applied to the drive-mounting screws. Stimulus may be applied in the X, Y or Z axis. Vibration specification is measured using RMS value.



2.5 Product Regulatory Compliance

Intel SSD DC S3520 Series meets or exceeds the regulatory or certification requirements listed in the following table:

Table 18: Product Regulatory Compliance Specifications

Title	Description	Region For Which Conformity Declared
TITLE 47-Telecommunications CHAPTER 1— FEDERAL COMMUNICATIONS COMMISSION PART 15 — RADIO FREQUENCY DEVICES ICES-003, Issue 4 Interference-Causing Equipment Standard Digital Apparatus	FCC Part 15B Class B CA/CSA-CEI/IEC CISPR 22:02. This is CISPR 22:1997 with Canadian Modifications	USA Canada
IEC 55024 Information Technology Equipment — Immunity characteristics— Limits and methods of measurement CISPR24:2010	EN-55024: 1998 and its amendments	European Union
IEC 55022 Information Technology Equipment — Radio disturbance Characteristics— Limits and methods of measurement CISPR24:2008 (Modified)	EN-55022: 2006 and its amendments	European Union
EN-60950-1 2 nd Edition	Information Technology Equipment — Safety — Part 1: General Requirements	USA/Canada
UL/CSA EN-60950-1 2 nd Edition	Information Technology Equipment — Safety — Part 1: General Requirements	USA/Canada

2.6 Reliability

Intel SSD DC S3520 Series meets or exceeds SSD endurance and data retention requirements as specified in the JESD218 standard. Reliability specifications are listed in the following table:

Table 19: Reliability Specifications

Parameter	Value
Uncorrectable Bit Error Rate (UBER)	< 1 sector per 10 ¹⁷ bits read
Uncorrectable bit error rate will not exceed one sector in the specified number of bits read. In the unlikely event of a non-recoverable read error, the SSD will report it as a read failure to the host; the sector in error is considered corrupt and is not returned to the host.	
Mean Time Between Failures (MTBF)	2 million hours
Mean Time Between Failures is estimated based on Telcordia* methodology and demonstrated through Reliability Demonstration Test (RDT).	
Power On/Off Cycles	24 per day



Parameter	Value
Power On/Off Cycles is defined as power being removed from the SSD, and then restored. Most host systems remove power from the SSD when entering suspend and hibernate as well as on a system shutdown.	
Insertion Cycles	50 on SATA cable 500 on backplane
SATA/power cable insertion/removal cycles.	
Data Retention	3 months power-off retention once SSD reaches rated write endurance at 40 °C
The time period for retaining data in the NAND at maximum rated endurance.	

Table 20: Endurance Rating

Capacities (GB)	JEDEC Workload			64K Sequential Write		
	Endurance ¹ (Terabyte Written)	DWPD (for 3 yrs.)	DWPD (for 5 yrs.)	Endurance ¹ (Terabyte Written)	DWPD (for 3 yrs.)	DWPD (for 5 yrs.)
240	599	2.27	1.37	1655	6	3.5
480	945	1.80	1.08	3126	6	3.5
800	1663	1.90	1.14	5332	6	3.5
760	1420	1.71	1.02	4140	6	3.5
960	1750	1.66	1.00	6252	6	3.5
1200	2455	1.87	1.12	7907	6	3.5
1600	2925	1.67	1.00	10481	6	3.5

Note:

1. Refer to JESD218 standard table 1 for UBER, FFR and other Enterprise SSD endurance verification requirements. Endurance verification acceptance criterion based on establishing <1E-16 at 60 confidence.



2.7 Temperature Sensor

The Intel® SSD DC S3520 Series has an internal temperature sensor with an accuracy of +/-2C over a range of -20C to +80C which can be monitored using two SMART attributes: Airflow Temperature (BEh) and Device Internal Temperature (C2h). Both attributes report the same temperature value. For more information on supported SMART attributes, see "SMART Attributes" on page 18.

2.8 Power Loss Capacitor Test

The Intel® SSD DC S3520 Series supports testing of the power loss capacitor, which can be monitored using the following SMART attribute: (175, AFh).

2.9 Hot Plug Support

Hot Plug insertion and removal is supported in the presence of a proper connector and appropriate operating system (OS), as described in the SATA 3.2 specification.

This product supports asynchronous signal recovery and issues an unsolicited COMINIT when first mated with a powered connector to guarantee reliable detection by a host system without hardware device detection.

User Data is protected from planned or unplanned power loss by the Enhanced Power Management technology on the Intel® SSD DC S3520 Series.

2.10 Self-Encrypting Drive (SED)

The Intel® SSD DC S3520 Series is a Self-Encrypting Drive (SED), meaning it supports hardware-based full-disk encryption (FDE). AES-256 based encryption is built into the drive and is transparent to the user. Authentication on power-up is done by way of the BIOS or ATA Security Feature Set.

3 Mechanical Information

Figure 1 shows the physical package information for the Intel SSD DC S3520 Series in the 2.5 inch form factors. All dimensions are in millimeters.

Figure 1: Intel SSD DC S3520 Series 2.5-inch Dimensions

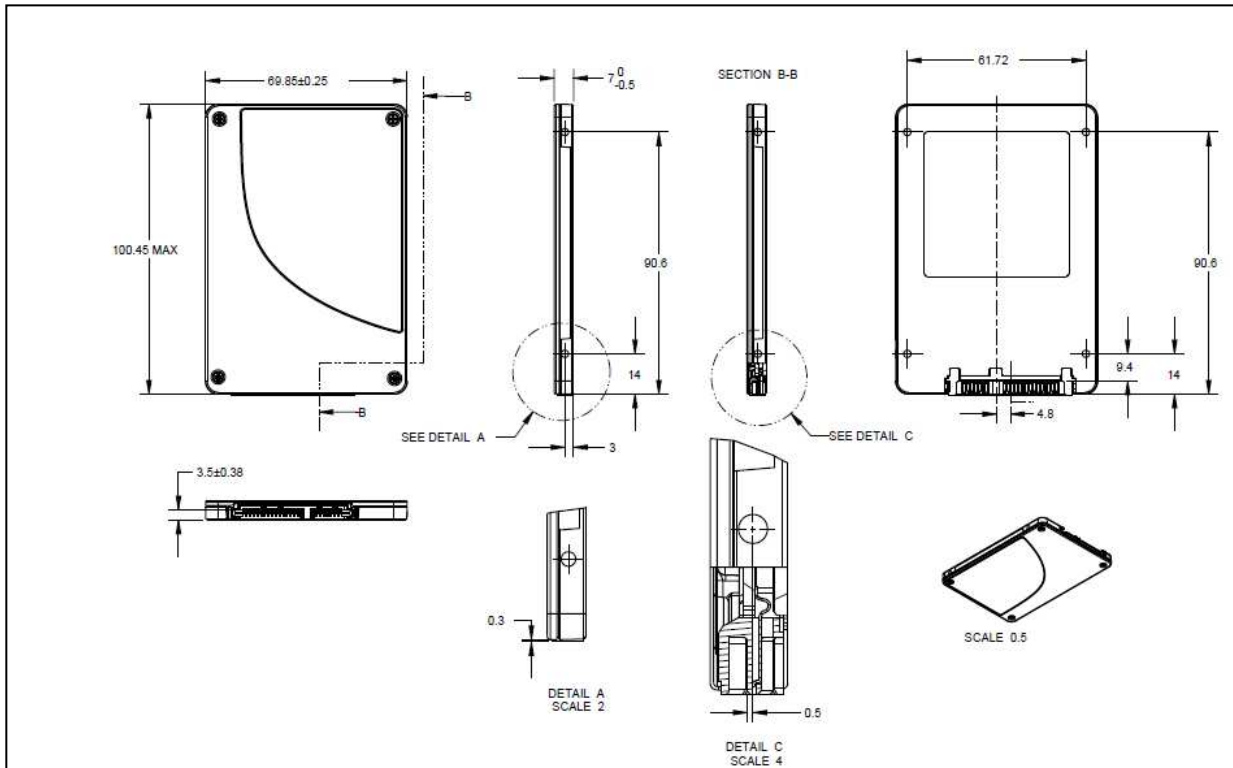
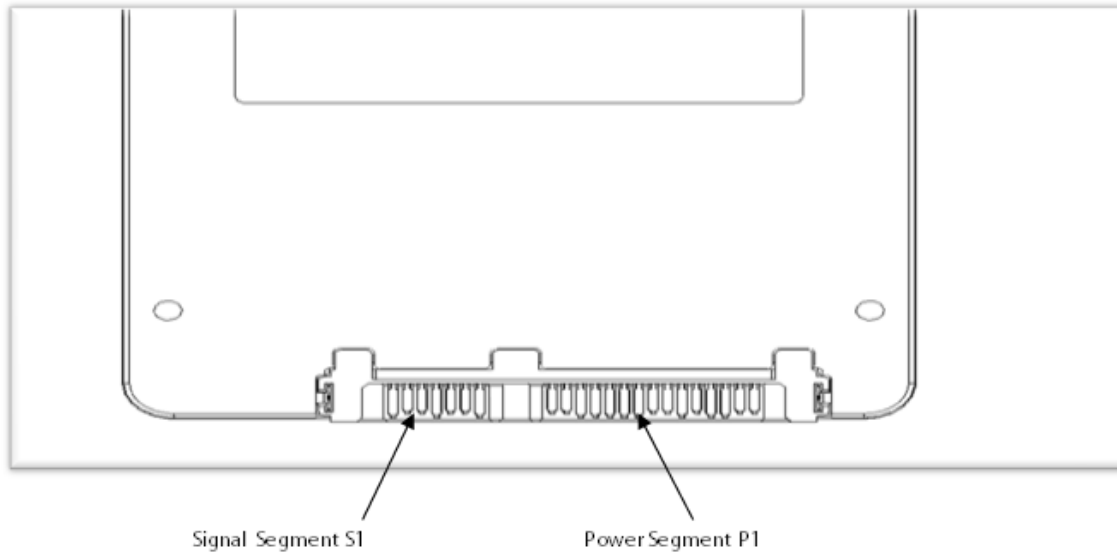

Figure 2 shows the physical package information for the Intel SSD DC S3520 Series in the M.2 form factors. All dimensions are in millimeters.

4 Pin and Signal Descriptions

4.1 2.5-inch Form Factor Pin Locations

Figure 3: Layout of 2.5-inch Form Factor Signal and Power Segment Pins



Note: 2.5-inch connector supports built in latching capability.

4.2 Connector Pin Signal Definitions

Table 21: Serial ATA Connector Pin Signal Definitions—2.5-inch Form Factors

Pin	Function	Definition
S1	Ground	1 st mate
S2	A+	Differential signal pair A
S3	A-	
S4	Ground	1 st mate
S5	B-	Differential signal pair B
S6	B+	
S7	Ground	1 st mate

Note: Key and spacing separate signal and power segments.



4.3 Power Pin Signal Definitions

Table 22: Serial ATA Power Pin Definitions—2.5-inch Form Factors

Pin ¹	Function	Definition	Mating Order
P1 ²	Not connected	(3.3V Power)	--
P2 ²	Not connected	(3.3V Power)	--
P3 ²	Not connected	(3.3V Power; pre-charge)	2 nd Mate
P4 ^{3,4}	Ground	Ground	1 st Mate
P5 ³	Ground	Ground	1 st Mate
P6 ³	Ground	Ground	1 st Mate
P7 ^{3,5}	V ₅	5V Power	1 st Mate
P8 ^{3,5}	V ₅	5V Power	2 nd Mate
P9 ^{3,5}	V ₅	5V Power	2 nd Mate
P10 ³	Ground	Ground	1 st Mate
P11 ⁶	DAS	Device Activity Signal	2 nd Mate
P12 ^{3,4}	Ground	Ground	1 st Mate
P13 ⁷	V ₁₂	12V Power	1 st Mate
P14 ⁷	V ₁₂	12V Power	2 nd Mate
P15 ⁷	V ₁₂	12V Power	2 nd Mate

Notes:

- All pins are in a single row, with a 1.27 mm (0.050-inch) pitch.
- Pins P1, P2 and P3 are connected together, although they are not connected internally to the device. The host may put 3.3V on these pins.
- The mating sequence is:
 - ground pins P4-P6, P10, P12 and the 5V power pin P7
 - signal pins and the rest of the 5V power pins P8-P9
- Ground connectors P4 and P12 may contact before the other 1st mate pins in both the power and signal connectors to discharge ESD in a suitably configured backplane connector.
- Power pins P7, P8, and P9 are internally connected to one another within the device.
- The host may ground P11 if it is not used for Device Activity Signal (DAS).
- Pins P13, P14 and P15 are internally connected to one another within the device. The host may put 12V on these pins.

Table 23: Serial ATA Power Pin Definitions—M.2-inch Form Factors

Pin	Function	Function	Pin
74	3.3V	GND	75
72	3.3V	GND	73
70	3.3V	GND	71
68	N/C	GND	69
x	Module Key M	N/C	67
x	Module Key M	Module Key M	x
x	Module Key M	Module Key M	x



Pin	Function	Function	Pin
x	Module Key M	Module Key M	x
58	Reserved for MFG_CLOCK	Module Key M	x
56	Reserved for MFG_DATA	GND	57
54	N/C	N/C	55
52	N/C	N/C	53
50	N/C	GND	51
48	N/C	SATA-A+	49
46	N/C	SATA-A-	47
44	N/C	GND	45
42	N/C	SATA-B-	43
40	N/C	SATA-B+	41
38	N/C	GND	39
36	N/C	N/C	37
34	N/C	N/C	35
32	N/C	GND	33
30	N/C	N/C	31
28	N/C	N/C	29
26	N/C	GND	27
24	N/C	N/C	25
22	N/C	N/C	23
20	N/C	GND	21
x	Module Key B	Module Key B	x
x	Module Key B	Module Key B	x
x	Module Key B	Module Key B	x
x	Module Key B	Module Key B	x
10	DAS/DSS#(I/O)	N/C	11
8	N/C	N/C	9
6	N/C	N/C	7
4	3.3V	N/C	5
2	3.3V	GND	3
		GND	1



5 Supported Command Sets

The Intel SSD DC S3520 Series supports all mandatory ATA (Advanced Technology Attachment) commands defined in the ATA8-ACS3 REV5F specification described in this section.

5.1 ATA General Feature Command Set

The Intel SSD DC S3520 Series supports the ATA General Feature command set (non- PACKET), which consists of:

- EXECUTE DEVICE DIAGNOSTIC
- SET FEATURES
- IDENTIFY DEVICE

Note: See Appendix A, “IDENTIFY DEVICE Command Data” for details on the sector data returned after issuing an IDENTIFY DEVICE command.

The Intel® SSD DC S3520 Series also supports the following optional commands:

- READ DMA
- WRITE DMA
- READ SECTOR(S)
- READ VERIFY SECTOR(S)
- READ MULTIPLE
- SEEK
- SET FEATURES
- WRITE SECTOR(S)
- SET MULTIPLE MODE¹
- WRITE MULTIPLE
- FLUSH CACHE
- READ BUFFER
- WRITE BUFFER
- NOP
- DOWNLOAD MICROCODE
- WRITE UNCORRECTABLE EXT

1. The only multiple supported will be multiple 1

5.2 Power Management Command Set

The Intel SSD DC S3520 Series supports the Power Management command set, which consists of:

- CHECK POWER MODE
- IDLE
- IDLE IMMEDIATE
- SLEEP
- STANDBY
- STANDBY IMMEDIATE



5.3 Security Mode Feature Set

The Intel SSD DC S3520 Series supports the Security Mode command set, which consists of:

- SECURITY SET PASSWORD
- SECURITY UNLOCK
- SECURITY ERASE PREPARE
- SECURITY ERASE UNIT
- SECURITY FREEZE LOCK
- SECURITY DISABLE PASSWORD

5.4 SMART Command Set

The Intel SSD DC S3520 Series supports the SMART command set, which consists of:

- SMART READ DATA
- SMART READ ATTRIBUTE THRESHOLDS
- SMART ENABLE/DISABLE ATTRIBUTE AUTOSAVE
- SMART SAVE ATTRIBUTE VALUES
- SMART EXECUTE OFF-LINE IMMEDIATE
- SMART READ LOG SECTOR
- SMART WRITE LOG SECTOR
- SMART ENABLE OPERATIONS
- SMART DISABLE OPERATIONS
- SMART RETURN STATUS
- SMART ENABLE/DISABLE AUTOMATIC OFFLINE

5.4.1 Attributes

The following table lists the SMART attributes supported by the Intel SSD DC S3520 Series and the corresponding status flags and threshold settings.

Table 24: SMART Attributes

ID	Attribute	Status Flags						Threshold
		SP	EC	ER	PE	OC	PW	
05h	Re-allocated Sector Count The raw value of this attribute shows the number of retired blocks since leaving the factory (grown defect count).	1	1	0	0	1	0	0 (none)
09h	Power-On Hours Count The raw value reports power-on time, cumulative over the life of the SSD, integer number in hour time units.	1	1	0	0	1	0	0 (none)
0Ch	Power Cycle Count The raw value of this attribute reports the cumulative number of power cycle events over the life of the device.	1	1	0	0	1	0	0 (none)
AAh	Available Reserved Space (See Attribute E8)	1	1	0	0	1	1	10



ID	Attribute	Status Flags						Threshold
		SP	EC	ER	PE	OC	PW	
ABh	<p>Program Fail Count</p> <p>The raw value of this attribute shows total count of program fails and the normalized value, beginning at 100, shows the percent remaining of allowable program fails.</p>	1	1	0	0	1	0	0 (none)
ACh	<p>Erase Fail Count</p> <p>The raw value of this attribute shows total count of erase fails and the normalized value, beginning at 100, shows the percent remaining of allowable erase fails.</p>	1	1	0	0	1	0	0 (none)
A Eh	<p>Unexpected Power Loss</p> <p>Also known as "Power-off Retract Count" per magnetic-drive terminology.</p> <p>Reports number of unclean shutdowns, cumulative over the life of the SSD.</p> <p>An "unclean shutdown" is the removal of power without STANDBY IMMEDIATE as the last command (regardless of PLI activity using capacitor power).</p>	1	1	0	0	1	0	0 (none)
AFh	<p>Power Loss Protection Failure</p> <p>Last test result as microseconds to discharge cap, saturates at max value. Also logs minutes since last test and lifetime number of tests.</p> <p>Bytes 0-1: Last test result as microseconds to discharge cap, saturates at max value. Test result expected in range 25 <= result <= 5000000, lower indicates specific error code</p> <p>Bytes 2-3: Minutes since last test, saturates at max value.</p> <p>Bytes 4-5: Lifetime number of tests, not incremented on power cycle, saturates at max value.</p>	1	1	0	0	1	1	10
B7h	<p>SATA Downshift Count</p> <p>The count of the number of times SATA interface selected lower signaling rate due to error.</p>	1	1	0	0	1	0	0 (none)
B8h	<p>End-to-End Error Detection Count</p> <p><i>Raw value:</i> reports number of LBA tag mismatches in end-to-end data protection path.</p> <p><i>Normalized value:</i> always 100.</p>	1	1	0	0	1	1	90
BBh	<p>Uncorrectable Error Count</p> <p>The raw value shows the count of errors that could not be recovered using Error Correction Code (ECC).</p> <p><i>Normalized value:</i> always 100.</p>	1	1	0	0	1	0	0 (none)
BEh	<p>Case Temperature - Reports the SSD case temperature.</p> <p>Same values as reported in the attribute C2h.</p> <p>Raw value suggests 100 - case temperature in C degrees.</p>	1	0	0	0	1	0	0 (none)
C0h	<p>Power-Off Retract Count (Unsafe Shutdown Count)</p> <p>The raw value of this attribute reports the cumulative number of unsafe (unclean) shutdown events over the life of the device. An unsafe shutdown occurs whenever the device is powered off without STANDBY IMMEDIATE being the last command.</p>	1	1	0	0	1	0	0 (none)