



Chipsmall Limited consists of a professional team with an average of over 10 year of expertise in the distribution of electronic components. Based in Hongkong, we have already established firm and mutual-benefit business relationships with customers from,Europe,America and south Asia,supplying obsolete and hard-to-find components to meet their specific needs.

With the principle of “Quality Parts,Customers Priority,Honest Operation,and Considerate Service”,our business mainly focus on the distribution of electronic components. Line cards we deal with include Microchip,ALPS,ROHM,Xilinx,Pulse,ON,Everlight and Freescale. Main products comprise IC,Modules,Potentiometer,IC Socket,Relay,Connector.Our parts cover such applications as commercial,industrial, and automotives areas.

We are looking forward to setting up business relationship with you and hope to provide you with the best service and solution. Let us make a better world for our industry!



Contact us

Tel: +86-755-8981 8866 Fax: +86-755-8427 6832

Email & Skype: info@chipsmall.com Web: www.chipsmall.com

Address: A1208, Overseas Decoration Building, #122 Zhenhua RD., Futian, Shenzhen, China



NOTICE—These drawings, specifications, or other data (1) are, and remain the property of Allied Corporation (2) must be returned upon request; and (3) are confidential and are not to be disclosed to any person other than those to whom they are given by Allied Corporation. The furnishing of these drawings, specifications, or other data by Allied Corporation, or by any other person, to anyone for any purpose is not to be regarded by implication or otherwise as in any manner licensing, granting rights or permitting such holder or any other person to manufacture, use or sell any product, process or design, patented or otherwise, that may in any way be related to or disclosed by said drawings, specifications or other data.

REVISIONS				
SYM	ZONE	DESCRIPTION	DATE	APPROVED
D		REDRAWN, NO CHANGE (WAS 2 SHT'S)		
E		800 DOCUMENT NOS. INCORPORATED CHANGED FSCM NO. TO 77820 ECN: 75005-342	7/23/87	[Signature]

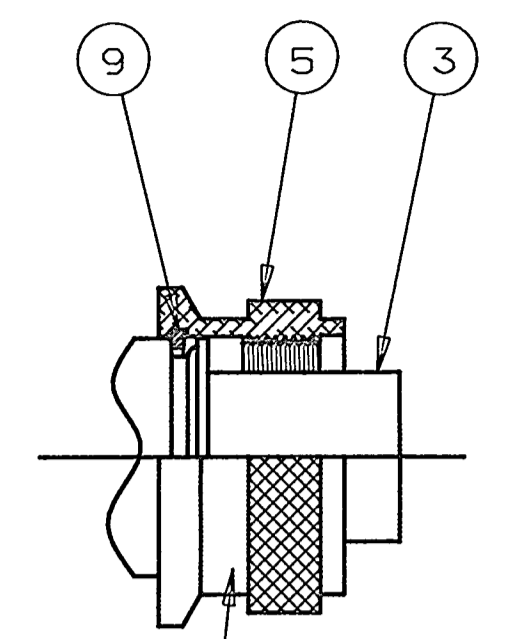

STAMP PART NO. ON THIS SURFACE ON SIZE 10 CONNECTORS ONLY

COUPLING RING ASSEMBLY (SIZE 10SL ONLY)

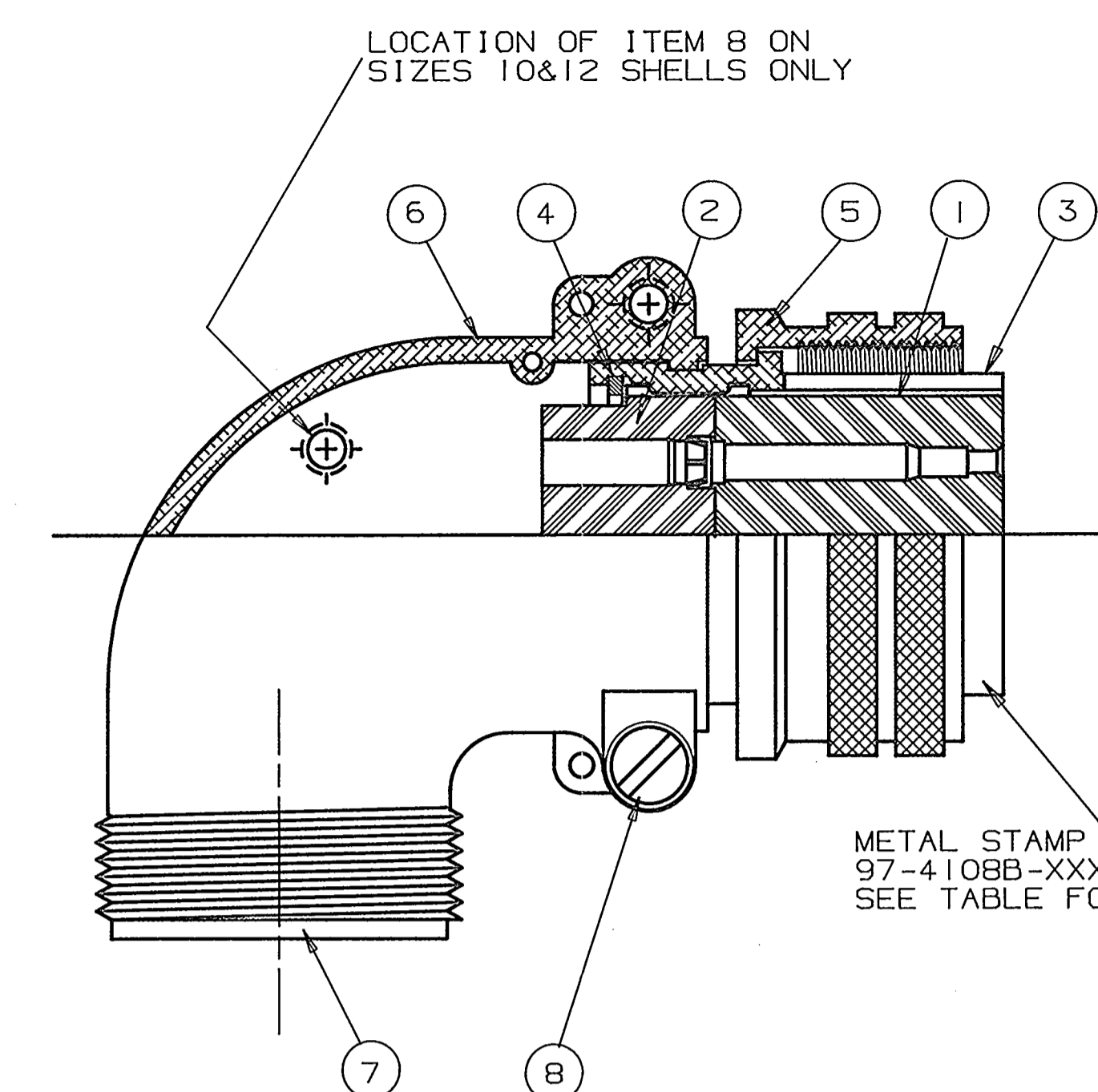

METAL STAMP WITH .062 CHARACTERS AMPHENOL PART NO. 97-4108B-XXXX-XXXSX ON THIS SURFACE. SEE TABLE FOR XXXX DIGITS.

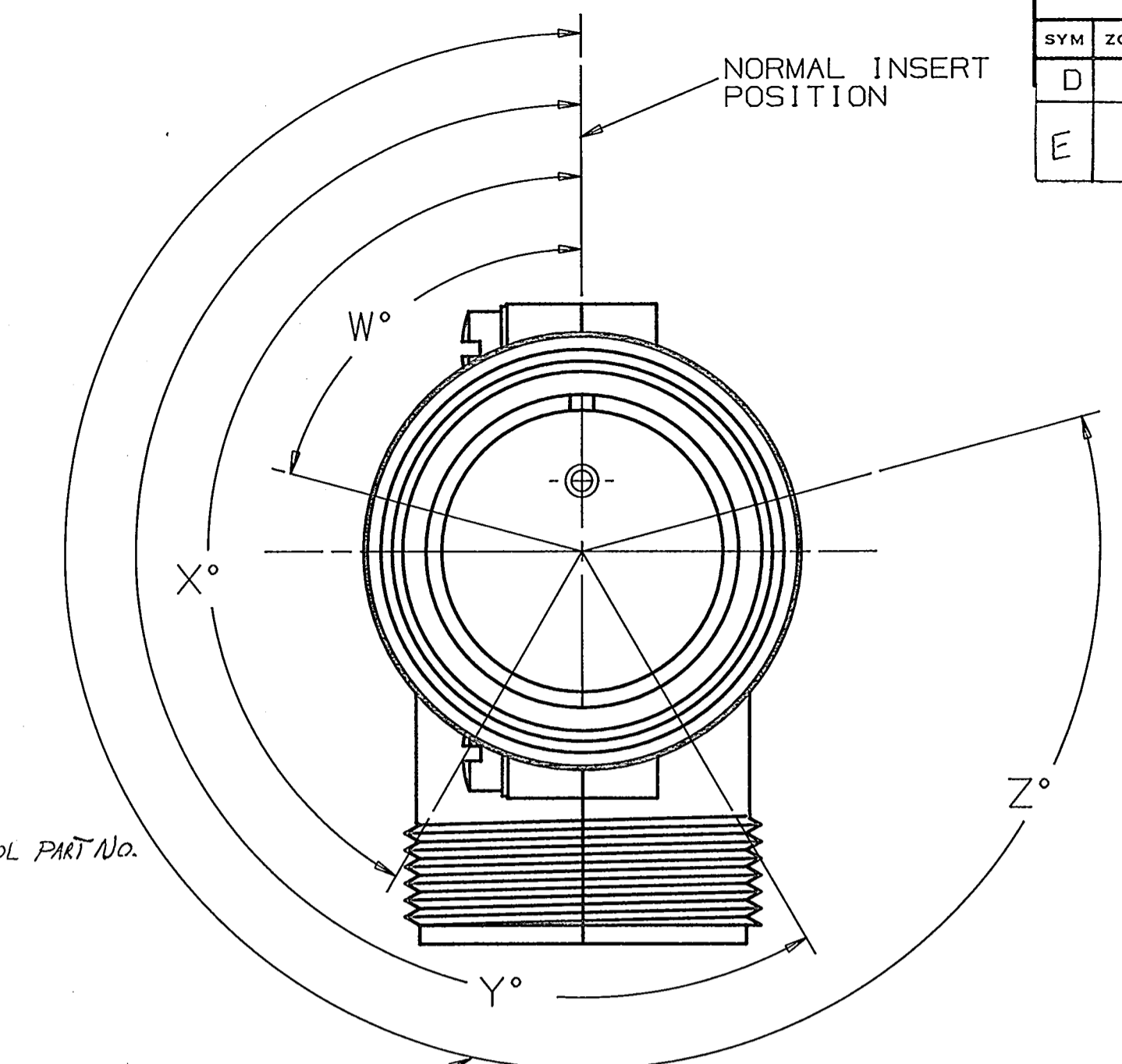

"W", "X", "Y", & "Z" LOCATIONS INDICATE ALTERNATE INSERT POSITIONS, SEE NOTE 2.

AMPHENOL PART NUMBER	SHELL SIZE	INSERT CONFIG.	ITEM 1 SOCKET INSERT I REQ'D.	ITEM 2 RETENTION DISC I REQ'D.	ITEM 3 RECEPTACLE SHELL I REQ'D.	ITEM 4 RETAINING RING I REQ'D.	ITEM 5 COUPLING RING I REQ'D.	ITEM 6 SPLIT BACKSHELL I REQ'D.	ITEM 7 SPLIT BACKSHELL I REQ'D.	ITEM 8 SCREW & LOCKWASHER REQ'D.	ITEM 9 RETAINER RING I REQ'D.	ALTERNATE INSERT POSITIONS				BENDIX NO.	
												W°	X°	Y°	Z°		
97-4108B-10SL-3SX	10SL	-3	97-410SL-3SF	97-410SL-3SR	97-81W-10SL (639)	97-94-10SL	97-92-10SL (639)	97-98-12F (639)	97-98-12M (639)	34-61 (639)	1	97-94-14-3	---	---	---	---	10-824-142-3(C)
97-4108B-10SL-4SX	10SL	-4	97-410SL-4SF	97-410SL-4SR	97-81W-10SL (639)	97-94-10SL	97-92-10SL (639)	97-98-12F (639)	97-98-12M (639)	34-61 (639)	1	97-94-14-3	---	---	---	---	142-4(C)
97-4108B-12S-3SX	12S	-3	97-412S-3SF	97-412S-3SR	97-81W-12S (639)	97-94-12	97-92-12S (639)	97-98-12F (639)	97-98-12M (639)	34-61 (639)	1		70°	145°	215°	290°	143-3(C)
97-4108B-14S-1SX	14S	-1	97-414S-1SF	97-414S-1SR	97-81W-14S (639)	97-94-14	97-92-14S (639)	97-98-14F (639)	97-98-14M (639)	34-61 (639)	2		---	---	---	---	146-1(C)
97-4108B-14S-2SX	14S	-2	97-414S-2SF	97-414S-2SR	97-81W-14S (639)	97-94-14	97-92-14S (639)	97-98-14F (639)	97-98-14M (639)	34-61 (639)	2		---	120°	240°	---	146-2(C)
97-4108B-14S-5SX	14S	-5	97-414S-5SF	97-414S-5SR	97-81W-14S (639)	97-94-14	97-92-14S (639)	97-98-14F (639)	97-98-14M (639)	34-61 (639)	2		---	110°	---	---	146-5(C)
97-4108B-14S-7SX	14S	-7	97-414S-7SF	97-414S-7SR	97-81W-14S (639)	97-94-14	97-92-14S (639)	97-98-14F (639)	97-98-14M (639)	34-61 (639)	2		90°	180°	270°	---	146-7(C)
97-4108B-16S-1SX	16S	-1	97-416S-1SF	97-416S-1SR	97-81W-16S (639)	97-94-16	97-92-16S (639)	97-98-16G (639)	97-98-16T (639)	34-61 (639)	2		80°	---	---	280°	148-1(C)
97-4108B-16S-8SX	16S	-8	97-416S-8SF	97-416S-8SR	97-81W-16S (639)	97-94-16	97-92-16S (639)	97-98-16G (639)	97-98-16T (639)	34-61 (639)	2		---	170°	265°	---	148-8(C)
97-4108B-18-1SX	18	-1	97-418-1SF	97-418-1SR	97-81W-18 (639)	97-94-18	97-92-18 (639)	97-98-18F (639)	97-98-18M (639)	34-61 (639)	2		70°	145°	215°	290°	150-1(C)
97-4108B-18-4SX	18	-4	97-418-4SF	97-418-4SR	97-81W-18 (639)	97-94-18	97-92-18 (639)	97-98-18F (639)	97-98-18M (639)	34-61 (639)	2		35°	110°	250°	325°	150-4(C)
97-4108B-18-11SX	18	-11	97-418-11SF	97-418-11SR	97-81W-18 (639)	97-94-18	97-92-18 (639)	97-98-18F (639)	97-98-18M (639)	34-61 (639)	2		---	170°	265°	---	150-11(C)
97-4108B-18-12SX	18	-12	97-418-12SF	97-418-12SR	97-81W-18 (639)	97-94-18	97-92-18 (639)	97-98-18F (639)	97-98-18M (639)	34-61 (639)	2		80°	---	---	280°	150-12(C)
97-4108B-18-19SX	18	-19	97-418-19SF	97-418-19SR	97-81W-18 (639)	97-94-18	97-92-18 (639)	97-98-18F (639)	97-98-18M (639)	34-61 (639)	2		---	120°	240°	---	150-19(C)
97-4108B-18-20SX	18	-20	97-418-20SF	97-418-20SR	97-81W-18 (639)	97-94-18	97-92-18 (639)	97-98-18F (639)	97-98-18M (639)	34-61 (639)	2		90°	180°	270°	---	150-20(C)
97-4108B-20-4SX	20	-4	97-420-4SF	97-420-4SR	97-81W-20 (639)	97-94-20	97-92-20 (639)	97-98-20G (639)	97-98-20T (639)	34-61 (639)	2		45°	110°	250°	---	151-4(C)
97-4108B-20-7SX	20	-7	97-420-7SF	97-420-7SR	97-81W-20 (639)	97-94-20	97-92-20 (639)	97-98-20G (639)	97-98-20T (639)	34-61 (639)	2		80°	110°	250°	280°	151-7(C)
97-4108B-20-27SX	20	-27	97-420-27SF	97-420-27SR	97-81W-20 (639)	97-94-20	97-92-20 (639)	97-98-20G (639)	97-98-20T (639)	34-61 (639)	2		35°	110°	250°	325°	151-27(C)
97-4108B-22-14SX	22	-14	97-422-14SF	97-422-14SR	97-81W-22 (639)	97-94-22	97-92-22 (639)	97-98-22G (639)	97-98-22T (639)	34-61 (639)	2		80°	110°	250°	280°	152-14(C)
97-4108B-24-2SX	24	-2	97-424-2SF	97-424-2SR	97-81W-24 (639)	97-94-24	97-92-24 (639)	97-98-24G (639)	97-98-24T (639)	34-61 (639)	2		80°	---	---	280°	153-2(C)
97-4108B-28-9SX	28	-9	97-428-9SF	97-428-9SR	97-81W-28 (639)	97-94-28	97-92-28 (639)	97-98-28G (639)	97-98-28T (639)	34-61 (639)	2		80°	110°	250°	280°	154-9(C)
97-4108B-28-11SX	28	-11	97-428-11SF	97-428-11SR	97-81W-28 (639)	97-94-28	97-92-28 (639)	97-98-28G (639)	97-98-28T (639)	34-61 (639)	2		80°	110°	250°	280°	154-11(C)
97-4108B-28-12SX	28	-12	97-428-12SF	97-428-12SR	97-81W-28 (639)	97-94-28	97-92-28 (639)	97-98-28G (639)	97-98-28T (639)	34-61 (639)	2		90°	180°	270°	---	154-12(C)
97-4108B-28-20SX	28	-20	97-428-20SF	97-428-20SR	97-81W-28 (639)	97-94-28	97-92-28 (639)	97-98-28G (639)	97-98-28T (639)	34-61 (639)	2		80°	110°	250°	280°	154-20(C)
97-4108B-28-21SX	28	-21	97-428-21SF	97-428-21SR	97-81W-28 (639)	97-94-28	97-92-28 (639)	97-98-28G (639)	97-98-28T (639)	34-61 (639)	2		80°	110°	250°	280°	154-21(C)
97-4108B-32-8SX	32	-8	97-432-8SF	97-432-8SR	97-81W-32 (639)	97-94-32	97-92-32 (639)	97-98-32G (639)	97-98-32T (639)	34-61 (639)	2		80°	125°	235°	280°	155-8(C)
97-4108B-32-414SX	32	-414	97-432-414SF	97-432-414SR	97-81W-32 (639)	97-94-32	97-92-32 (639)	97-98-32G (639)	97-98-32T (639)	34-61 (639)	2		80°	110°	250°	280°	155-AC(C)
97-4108B-36-10SX	36	-10	97-436-10SF	97-436-10SR	97-81W-36 (639)	97-94-36	97-92-36 (639)	97-98-36G (639)	97-98-36T (639)	34-61 (639)	2		80°	125°	235°	280°	156-10(C)

- NOTES!
- METAL STAMP CONNECTOR WITH SPECIFIC CONTROL NUMBER (DATE CODE PER 9-8909)
 - SUFFIX IN PART NO. INDICATES ALTERNATE INSERT POSITIONS. NO SUFFIX REQUIRED FOR NORMAL INSERT POSITION.
 - PACK IN POLYCEL BAG OR EQUIVALENT AND IDENTIFY—
"AMPHENOL"
AMPHENOL PART NO.
MONTH AND YEAR MANUFACTURED
QUANTITY AND UNIT (EACH)

PART NO. BREAKDOWN

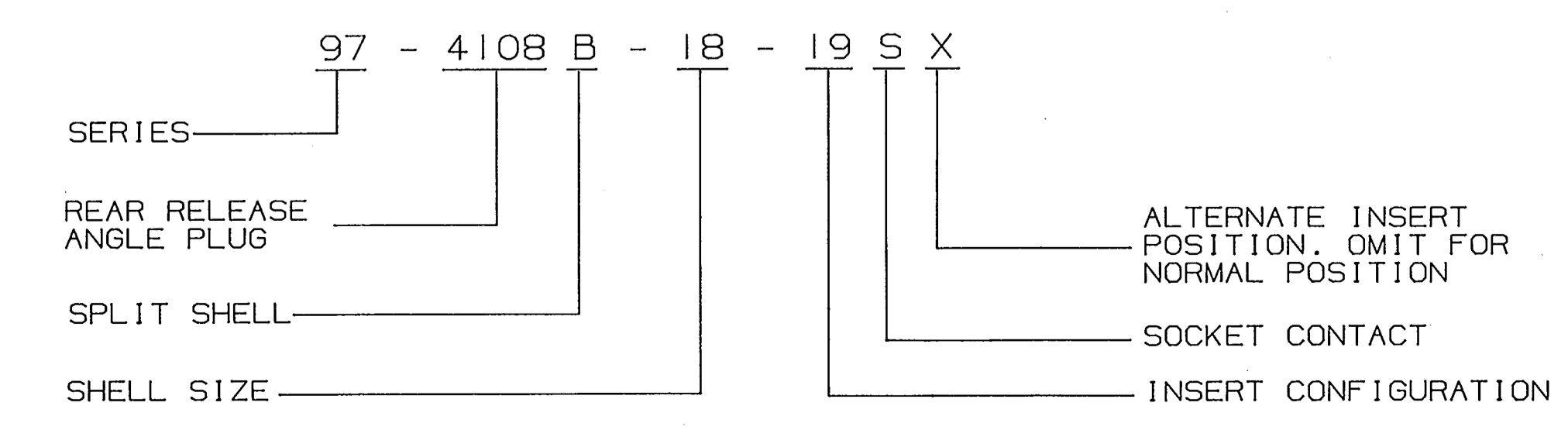

UNLESS OTHERWISE SPECIFIED
LINEAR DIMENSIONS ARE IN INCHES
TOLERANCES: XXXL 0.00,
XXX M, Xs. 1 ANGLES ± 2°
OTHER STANDARDS PER 9-3800
AND DDD-D-1000.

ITEM NO.	PART OR IDENTIFYING NO.	QTY REQD.	NOMENCLATURE OR DESCRIPTION
LIST OF MATERIALS OR PARTS LIST			
DRAWN W. WUNGLUCK DATE 11-12-82			
CHECKED W.W. 11-18-82			
APPROVED W. KAILUS 11-18-82			
EPA/EAR AI-1546-097-907480			
ENGINEERING RELEASE NO. A15010 A15039 1-7-83 1-6-84			
INDUSTRIAL ENGRG APPD. H.J. KROPP 11-18-82			
DESIGN ACTIVITY APPD.			
EXPERIMENTAL NO.			
DWG SIZE D		FSCM NO. 77820	REV
SCALE 2=1		WT. EST.	ACT. SHEET OF