



Chipsmall Limited consists of a professional team with an average of over 10 year of expertise in the distribution of electronic components. Based in Hongkong, we have already established firm and mutual-benefit business relationships with customers from,Europe,America and south Asia,supplying obsolete and hard-to-find components to meet their specific needs.

With the principle of "Quality Parts,Customers Priority,Honest Operation,and Considerate Service",our business mainly focus on the distribution of electronic components. Line cards we deal with include Microchip,ALPS,ROHM,Xilinx,Pulse,ON,Everlight and Freescale. Main products comprise IC,Modules,Potentiometer,IC Socket,Relay,Connector.Our parts cover such applications as commercial,industrial, and automotives areas.

We are looking forward to setting up business relationship with you and hope to provide you with the best service and solution. Let us make a better world for our industry!



Contact us

Tel: +86-755-8981 8866 Fax: +86-755-8427 6832

Email & Skype: info@chipsmall.com Web: www.chipsmall.com

Address: A1208, Overseas Decoration Building, #122 Zhenhua RD., Futian, Shenzhen, China



THIS DOCUMENT IS THE PROPERTY OF
KEYSTONE ELECTRONICS CORP. AND
SHALL NOT BE REPRODUCED, DISTRIBUTED
OR USED AS A BASIS FOR MANUFACTURE
WITHOUT PRIOR WRITTEN PERMISSION
FROM KEYSTONE ELECTRONICS CORP.

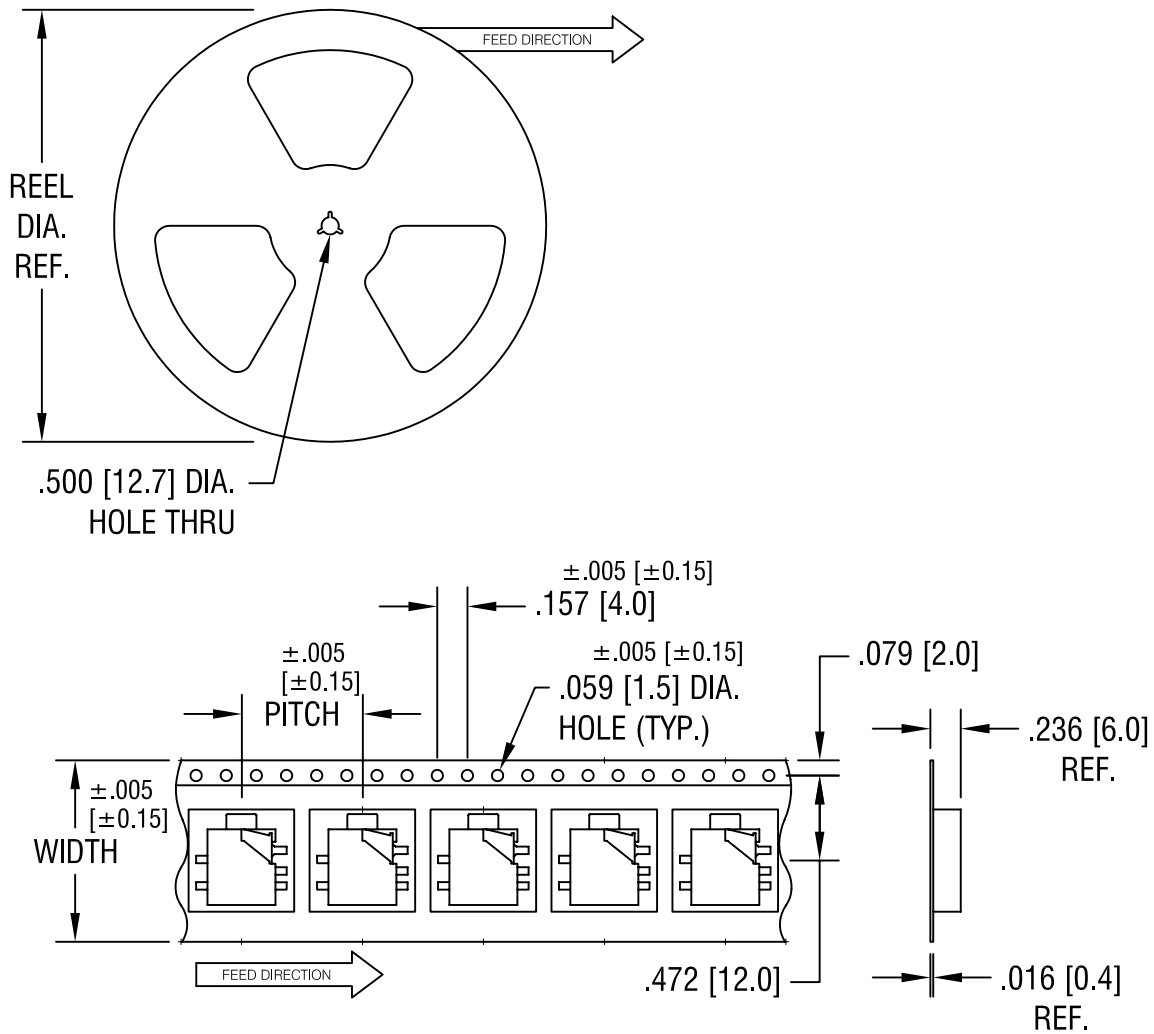

NOTES:

TAPE AND REEL SPECIFICATIONS:

1. TAPE:

MAT'L - ALL CONDUCTIVE POLYSTYRENE CARRIER

ANSI/EIA-481 STANDARD

.945 [24.0] WIDE; .630 [16.0] PITCH

2. REEL:

15.0 [381.0] DIA. 1000 PIECES OF

PART NO. 980 PER REEL.

KEYSTONE ELECTRONICS CORP.

ASTORIA, N.Y. 11105-2017

PART NAME

2.5mm SM STEREO JACK ON TAPE

MATERIAL

AS NOTED

FINISH

AS NOTED

DRN BY

BOONE

DATE

2.28.00

APP'D

LN

SCALE

X

10.17.06

CHANGE AS PER ECN 06-066

A

TOLERANCES

INCH [MM]

CODE

DWG NO.

DECIMAL ±.015 [±0.38]

C/M

980TR

ANGULAR ± 1°

UNLESS OTHERWISE SPECIFIED

DATE

DESCRIPTION

REV.

THIS DOCUMENT IS THE PROPERTY OF KEYSTONE ELECTRONICS CORP. AND SHALL NOT BE REPRODUCED, DISTRIBUTED OR USED AS A BASIS FOR MANUFACTURE WITHOUT PRIOR WRITTEN PERMISSION FROM KEYSTONE ELECTRONICS CORP.

ACTUAL SIZE

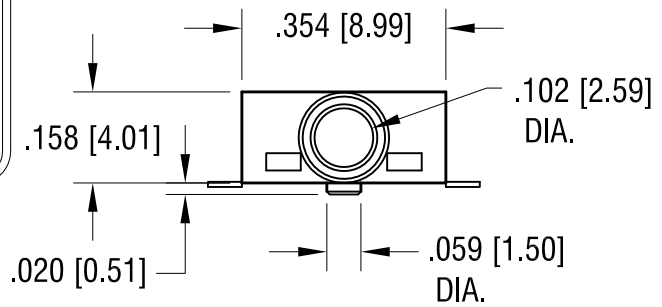
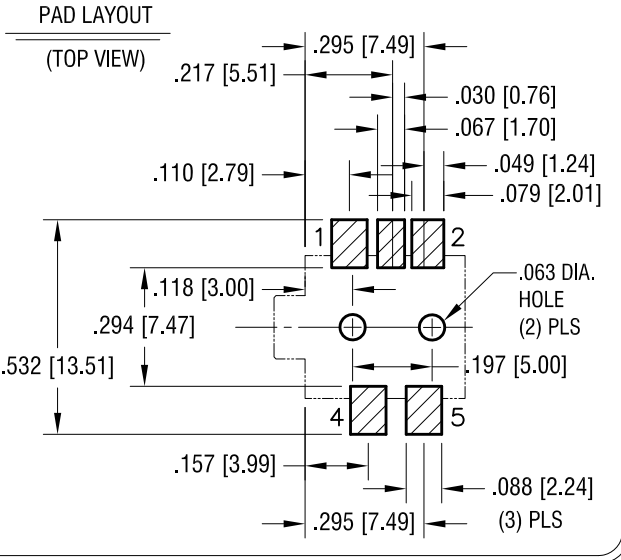
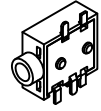

STEREO SCHEMATIC

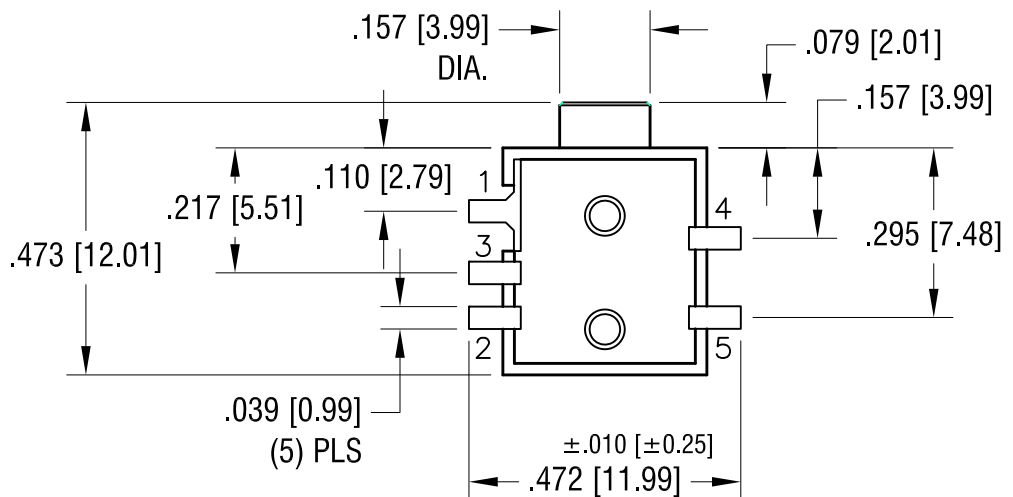
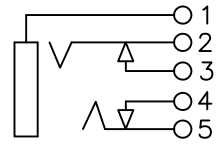

NOTES:

1. MAT'L:
 HOUSING: MAT'L- LCP, UL 94V-0
 GROUND TERMINAL: .012 [0.3] TH'K BRASS ①
 SPRING CONTACTS: .008 [0.2] TH'K PHOSPHOR BRONZE ② ⑤
 SHUNT TERMINALS: .012 [0.3] TH'K BRASS ③ ④
2. TAPE SPECIFICATIONS:
 MAT'L - ALL CONDUCTIVE POLYSTYRENE CARRIER
 ANSI/EIA-481 STANDARD
 24MM (.945) WIDE; 16MM (.630) PITCH
3. REEL SPECIFICATION:
 15 INCH DIA. 1000 PIECES

HOUSING WAS POLYAMIDE
 CHANGE AS PER ECN 13-041

5.20.13

A

KEYSTONE ELECTRONICS CORP.			
www.keyelco.com • ASTORIA, N.Y. 11105-2017 • Tel (718) 956-8900			
PART NAME			
2.5mm SURFACE MOUNT STEREO JACK			
MATERIAL			
AS NOTED			
FINISH		DRN BY	DATE
GOLD FLASH		BOONE	7.20.98
		APP'D	SCALE
		LN	3X
TOLERANCES	INCH [MM]	CODE	DWG NO.
DECIMAL	± .005 [± 0.13]	C	
ANGULAR	± 1°		
UNLESS OTHERWISE SPECIFIED			
			980

DATE	DESCRIPTION	REV.
------	-------------	------