



Chipsmall Limited consists of a professional team with an average of over 10 year of expertise in the distribution of electronic components. Based in Hongkong, we have already established firm and mutual-benefit business relationships with customers from,Europe,America and south Asia,supplying obsolete and hard-to-find components to meet their specific needs.

With the principle of “Quality Parts,Customers Priority,Honest Operation,and Considerate Service”,our business mainly focus on the distribution of electronic components. Line cards we deal with include Microchip,ALPS,ROHM,Xilinx,Pulse,ON,Everlight and Freescale. Main products comprise IC,Modules,Potentiometer,IC Socket,Relay,Connector.Our parts cover such applications as commercial,industrial, and automotives areas.

We are looking forward to setting up business relationship with you and hope to provide you with the best service and solution. Let us make a better world for our industry!



## Contact us

Tel: +86-755-8981 8866 Fax: +86-755-8427 6832

Email & Skype: info@chipsmall.com Web: www.chipsmall.com

Address: A1208, Overseas Decoration Building, #122 Zhenhua RD., Futian, Shenzhen, China



# PWM Controller

## Features

### Reduces system power consumption and fan noise

For PWM fan speed control, a PWM control circuit needs to be newly designed and configured.

By using this product, however, PWM control function fans can be fully utilized without the need for preparing new circuits, contributing to reducing the system power consumption and the fan noise.

### Can be common-powered by the fan power supply

The controller can be powered by the fan power supply of rated voltage 12, 24, and 48 VDC, and no separate supply is required.

### Maximum of four fans connectable

Up to four fans with PWM control function can be connected and controlled.

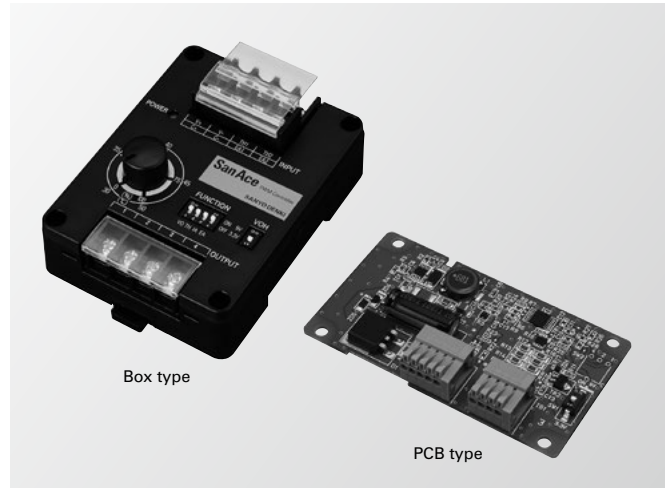

## Specifications

		Box type	PCB type		
Model no.		<b>9PC8666X-S001</b>	<b>9PC8045D-V001</b>	<b>9PC8045D-R001</b>	<b>9PC8045D-T001</b>
Size [mm]		86 (H)×66 (W)×38 (D)	80 (H)×45 (W)×17 (D)		
Rated voltage [V]		12/24/48			
Power consumption [W]		0.2*			
Operating temperature [°C]		-20 to +70			
Input terminal	Input voltage range [V] (V+, V-)	7 to 60			
	Control voltage range [V]	0 to 5.5			
Output terminal	PWM signal output	V <sub>OH</sub> (high level voltage): 3.3 or 5 VDC selectable			
	PWM frequency [kHz]	25			
	Output current	20 mA max. (total sum of 4 terminals)			
	Output breakdown voltage [V]	6.5			
	No. of connectable fans	Up to 4 fans			
Control functions**		Voltage control, Internal adjustment (variable resistor) control, External adjustment (variable resistor) control***, Thermistor control***	Voltage control	Variable resistor control***	Thermistor control***
Mounting method		DIN rail mounting or screw mounting	Screw mounting		
Mass [g]		110	27		
Material		Case: Plastic	PCB: FR-4		

\* When output terminals are turned on. \*\* Control functions are mutually exclusive for Box type.

\*\*\* Variable resistor and thermistor are not supplied with the controller and need to be prepared separately.

Be noted that if applied input voltage or frequency is out of range of the connected fan, how the fan speed responds to the PWM duty cycle may be altered.

## Front View (component names)

### Box type

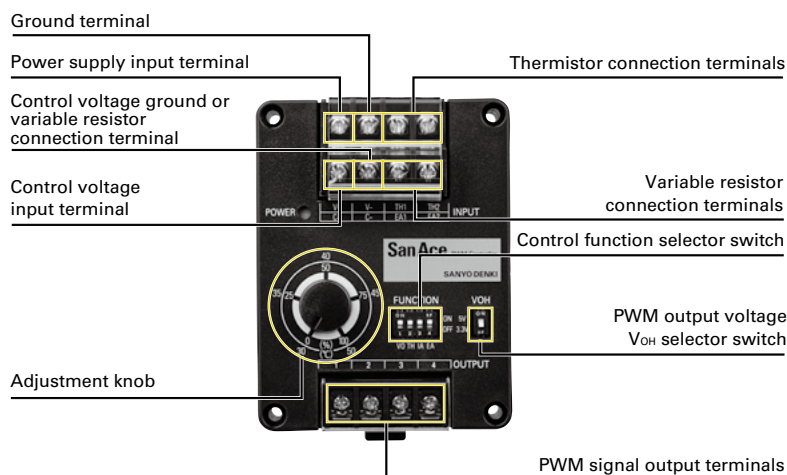

### PCB type

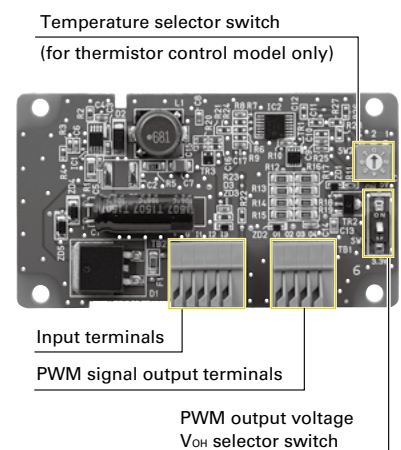

## ■ Connection Examples and PWM Signal Output Characteristics

Controller can be common-powered by the power supply for 12, 24, and 48 VDC rated voltage fans.  
It can also be powered by a separate supply as long as both supplies share the same ground.

### Voltage control

Output duty cycle controlled with input voltage of 0 to 5 VDC. \*Ensure that the input voltage does not exceed 5.5 VDC.

- Box type

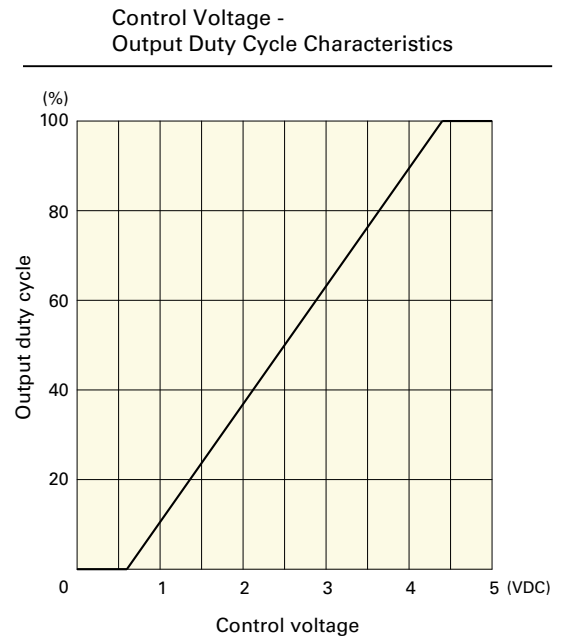
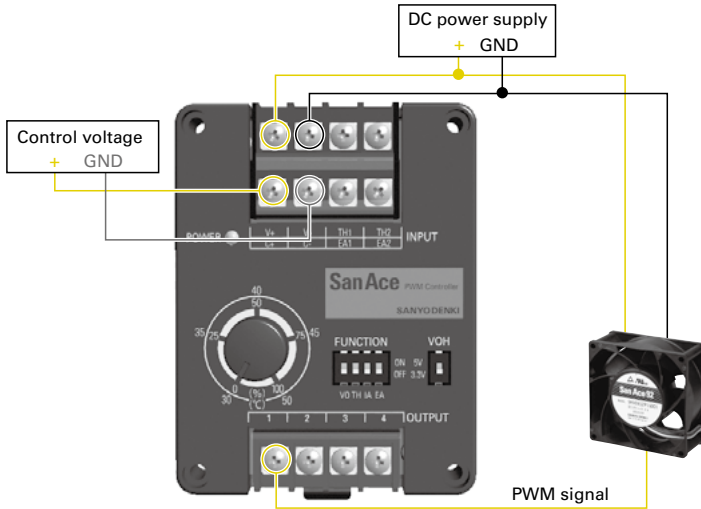

- PCB type (Model no.: 9PC8045D-V001)

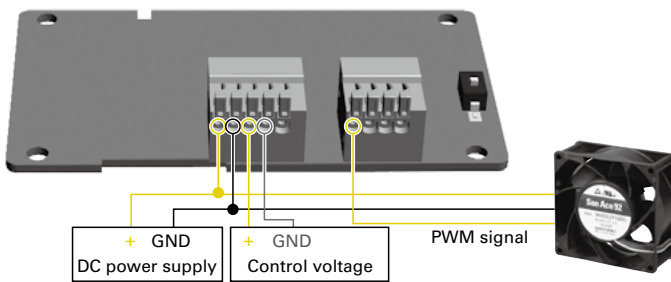

### Internal adjustment (variable resistor) control

Output duty cycle controlled with the adjustment knob.

- Box type

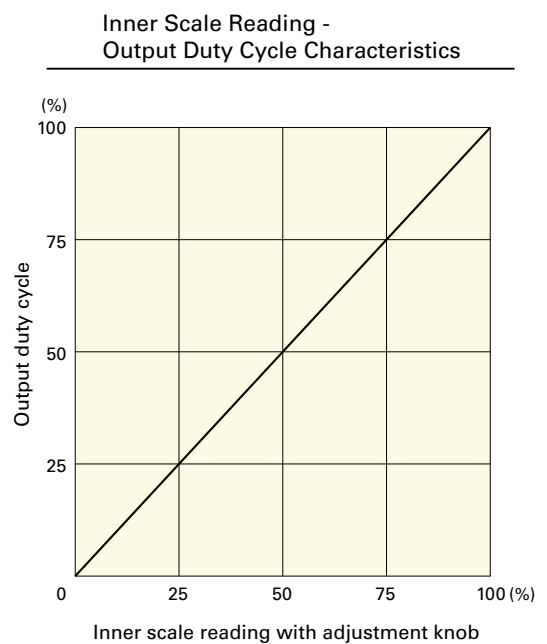
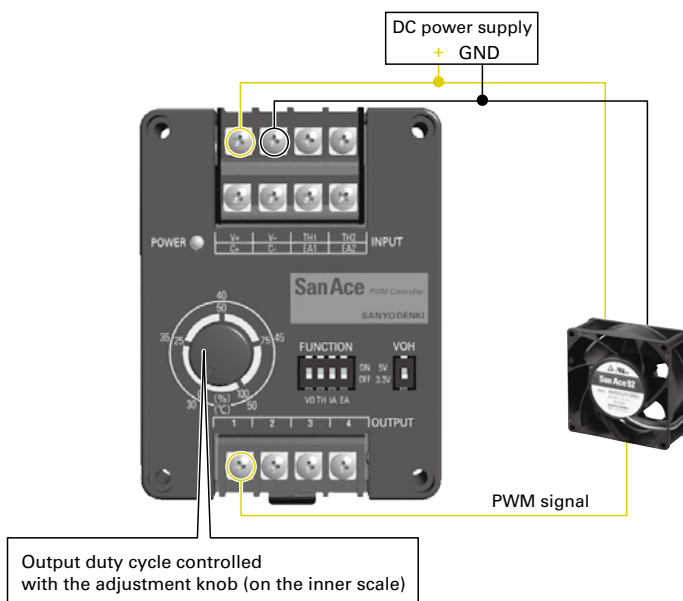

## PWM Controller

### External adjustment (variable resistor) control

Output duty cycle controlled with variable resistor connected to terminals.

- Box type

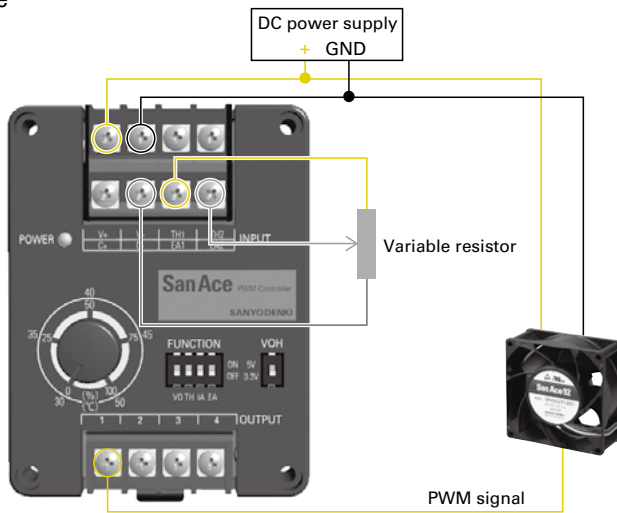

### Resistance - Output Duty Cycle Characteristics

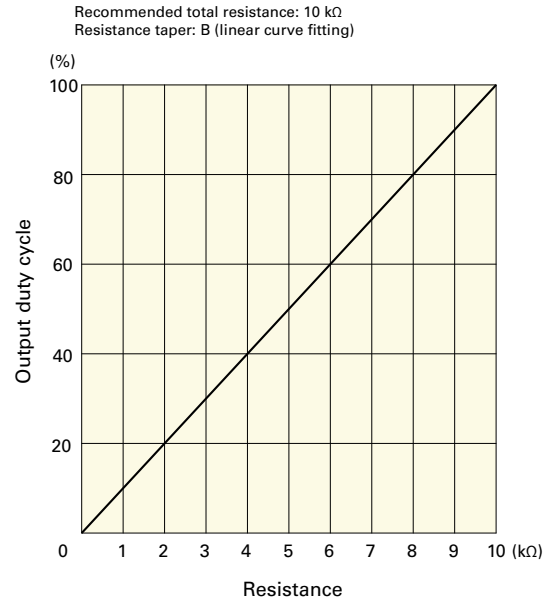

- PCB type (Model no.: 9PC8045D-R001)

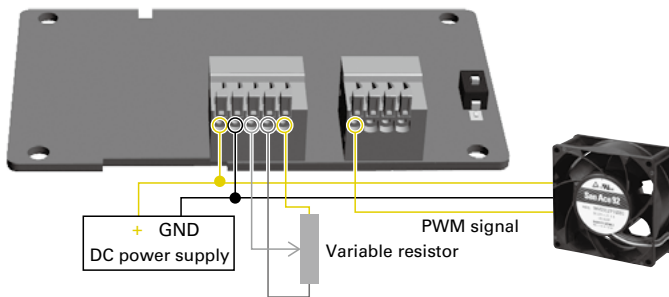

### Thermistor control

Automation control of output duty cycle in response to the temperature detected with an external thermistor.

- Box type

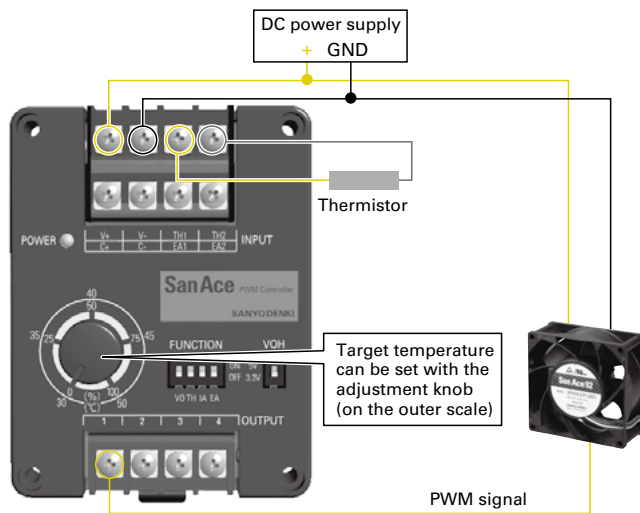

### Controlling Conditions

$T_{ST}$ : Temperature set with the adjustment knob (30 to 50°C)  
 $T_{TH}$ : Temperature detected with thermistor

Recommended thermistor conditions  
Type: NTC  
 $R_{25}$  (Resistance at 25°C): 10 kΩ  
B value:  $B_{25/85} = 3435$  K

Temperature conditions	Duty cycle	Fan rotational speed (For reference)
$T_{ST} < T_{TH}$	Increases	Increases
$T_{ST} > T_{TH}$	Decreases	Decreases
$T_{ST} \approx T_{TH}$	Maintained	Maintained

- PCB type (Model no.: 9PC8045D-T001)

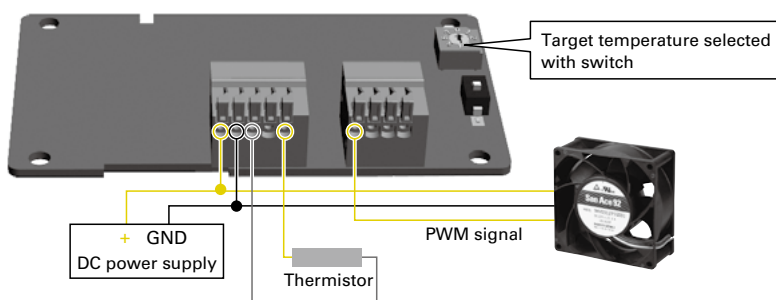

**Dimensions (unit: mm)**

• Box type

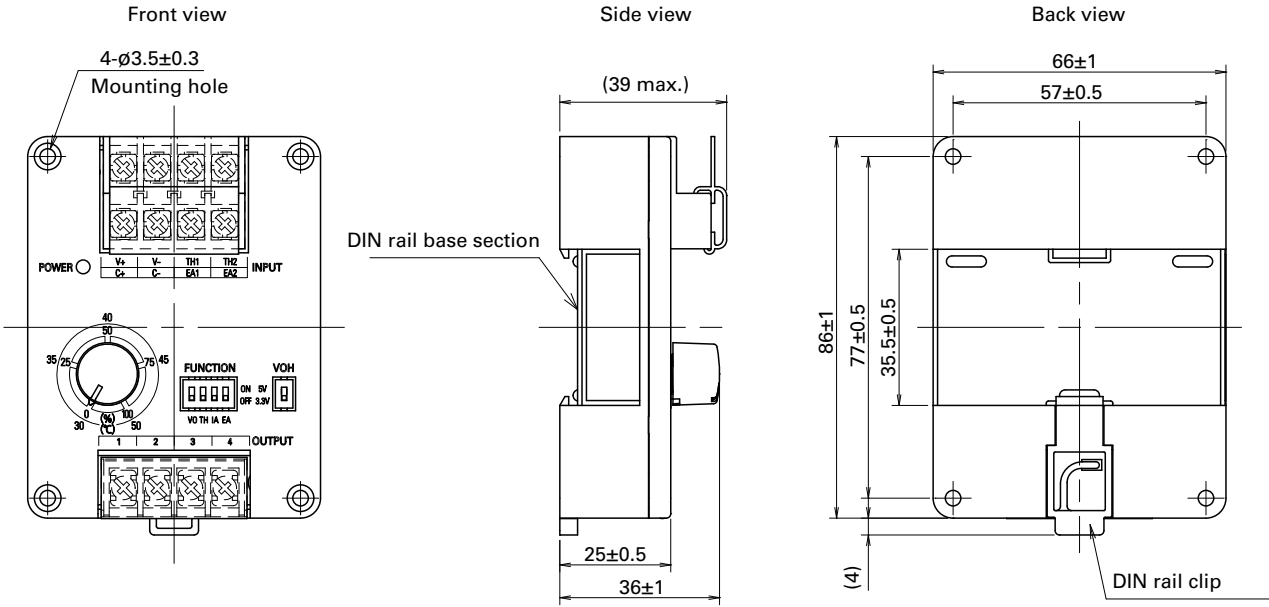

• PCB type

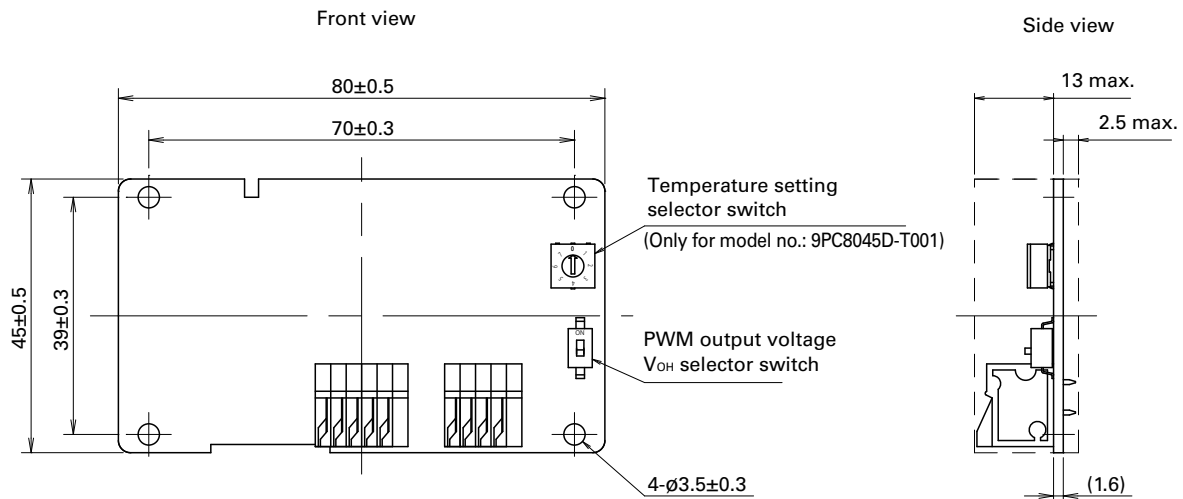



# Safety Precautions

## Box type

- To ensure that the product is used safely, be sure to read and fully understand the Safety Precautions and only use the product as directed.
- Read the Safety Precautions carefully before installing, connecting, operating, maintaining, or inspecting the product.
- The product has been designed and manufactured for use in general industrial machinery, and may not be used as a standalone product.
- The product of our company (hereafter referred to as "the product") falls into the category of the products specified in the Attached List 1, Item 16 (Class 85, Item 43) of the Export Trade Control Ordinance. To export the product as an individual part or to export a device into which the product is assembled, the "Information Requirements" and "Objective Requirements" that the Ministry of Economy, Trade and Industry established based on the "Catchall Controls" must be studied for applicability. Based on information on applicability and specified requirements, appropriate export procedures must be taken.
- When disposing of the product, treat it as industrial waste. For instructions on proper disposal methods, please contact local government authorities.
- When using the product in an environment with vibration, such as in a car or a ship, use it at your own discretion only after deploying sufficient safety measures and making prior evaluations. Fully understand the Safety Precautions described in this instruction manual before using the product.

**In order to prevent any possible bodily injury or damage to property or equipment, the following precautions for ensuring safety are displayed according to the following two ranks of importance:**

 <b>Danger</b>	Handling or using the product improperly and in disregard of the instructions with this mark may result in serious bodily injury or death.
 <b>Caution</b>	Handling or using the product improperly and in disregard of the instructions with this mark may result in bodily injury or physical damage.

\* Items marked 'Caution' may also result in serious bodily injury or death in some circumstances. Always follow the instructions for items marked 'Danger.'

## Danger

- If the product is used in medical appliances or other types of equipment that affect people's lives, sufficient safety-related evaluations and preparations must be made in advance, and the product or the type of equipment into which the product is assembled must be used under the full responsibility of the user.
- If the product is used in types of equipment that have a strong social and public impact, sufficient prior evaluations and safety-related evaluations and preparations must be made, and the product or the type of equipment into which the product is assembled must be used under the full responsibility of the user.
- The product is not designed to be used in a car or a ship. When using the product in an environment with vibration, such as in a car or a ship, use it at your own discretion only after deploying sufficient safety measures and making prior evaluations.
- Connect all wires properly and securely. Failure to do so may result in fire, burns, or electrical shock.
- Do not use the product in a location where there is flammable gas. Otherwise, it may result in fire, burns, or bodily injury.
- Do not operate the product when electronic components are exposed. Otherwise, it may result in electrical shock.
- Turn off the power and stop using the product immediately if you notice any sparks, smoke, odd odors, sounds, or anything unusual during operation. Failure to do so may result in fire, bodily injury, or electrical shock.
- Never allow the product to fall, topple over, or otherwise be subjected to excessive shocks when moving it. Otherwise, it may result in product failure.
- The product should be handled only by personnel with sufficient training and knowledge and under the full responsibility of the user.
- Never attempt to disassemble, repair, or alter the product in any way, as doing so may result in fire, burns, or electrical shock.

## Caution

### Handling

- Installation, placement, connections, wiring, or relocation of the product should be performed by knowledgeable or correctly licensed personnel. Never perform such work while the product is on. Failure to do so may result in bodily injury, fire, burns, or electrical shock.
- Never allow yourself to come into contact with the ends of wires or plugs when measuring insulation resistance or dielectric strength voltage. Otherwise, it may result in electrical shock.
- Never attempt to disassemble or alter the product in any way. Doing so may invalidate any warranties concerning the functions or performance of the product, and may also result in fire, burns, bodily injury, or electrical shock.

### Instruction

- Take measures to protect the device from potential damage caused by the product stopping during operation.
- Never use the product at voltages, temperatures, or any other settings which exceed those given in the product specifications. Otherwise, it may result in substandard operation, failure, fire, bodily injury, or electrical shock.
- Never remove the product nameplate or install the product so that the identification cannot be seen after installation. Otherwise, it may result in the product being improperly used, and subsequently result in fires.
- Do not turn the power supply ON/OFF on a ground wire. Otherwise, it may result in product failure.
- Do not apply excessive force to the product while it is operating. Otherwise, it may result in product failure.
- If you install and use the product in a car or a ship, we shall not be responsible for any faults caused by the environment of the car or ship in which the product is installed.

### Installation

- When fixing the product into place, be sure to take into consideration the product's weight and all other relevant factors. Failure to do so may result in the product or its parts falling, resulting in bodily injury or device failure.
- Never install or remove the product while it is wired.
- When fixing the product with screws, ensure correct tightening torque. If the tightening torque is over the recommended values, the product structure may deform or break.
- Take proper precautions against static electricity when making electrical connections. Failure to do so may result in device or product failure.
- Make electrical connections properly. Failure to do so may result in device failure, product failure, or product malfunction.
- Ensure that wires are fitted with insulation to prevent accidental short-circuiting. Failure to do so may result in device failure, product failure, or product malfunction.

### Operating environment

- Do not use or store the product where it is exposed to flammable or corrosive gas, water or oil splashes, dust or humidity, condensation, radioactive rays or direct sunlight, salty air or saltwater, or where the product may be contaminated by corrosive materials such as sulfurous water, sulfurous volcanic ash, organic solvents, acidic chemicals, alkali chemicals, nuclear fuel materials, or other hazardous substances. If it is used or stored in such places or environments, there is the possibility that a fire may occur, the product may malfunction or its performance may deteriorate.
- Do not use or store the product in locations and environments where it could be constantly exposed to vibrations, strong shocks, magnetic or electromagnetic noise, or in which electromagnetic noise overlaps into power voltage. Otherwise, it may result in product failure.
- Do not use or store the product in environments subject to sudden changes in temperature and humidity. Otherwise, it may result in product failure.



### Maintenance

- Only certified personnel with sufficient training and knowledge should perform maintenance and inspections. Otherwise, it may result in fire, burns, bodily injury, or electrical shock.
- Perform maintenance or inspections while the product is off. Otherwise, it may result in fire, burns, bodily injury, or electrical shock.
- Never use gasoline, paint thinner, benzene, or any other organic solvents to clean the product. Otherwise, it may result in product deformation or substandard operation.

## PCB type

- To ensure that the product is used safely, be sure to read and fully understand the Safety Precautions and only use the product as directed.
- Read the Safety Precautions carefully before installing, connecting, operating, maintaining, or inspecting the product.
- The product has been designed and manufactured for use in general industrial machinery, and may not be used as a standalone product.
- The product of our company (hereafter referred to as "the product") falls into the category of the products specified in the Attached List 1, Item 16 (Class 85, Item 43) of the Export Trade Control Ordinance. To export the product as an individual part or to export a product into which the product is assembled, the "Information Requirements" and "Objective Requirements" that the Ministry of Economy, Trade and Industry established based on the "Catchall Controls" must be studied for applicability. Based on information on applicability and specified requirements, appropriate export formalities must be performed.
- When disposing of the product, treat it as industrial waste. For instructions on proper disposal methods, please contact local government authorities.
- When using the product in an environment with vibration, such as in a car or a ship, use it at your own discretion only after deploying sufficient safety measures and making prior evaluations. Fully understand the Safety Precautions described in this instruction manual before using the product.

**In order to prevent any possible bodily injury or damage to property or equipment, the following precautions for ensuring safety are displayed according to the following two ranks of importance:**

 <b>Danger</b>	Handling or using the product improperly and in disregard of the instructions with this mark may result in serious bodily injury or death.
 <b>Caution</b>	Handling or using the product improperly and in disregard of the instructions with this mark may result in bodily injury or physical damage.

\* Items marked 'Caution' may also result in serious bodily injury or death in some circumstances. Always follow the instructions for items marked 'Danger.'

### **Danger**

- If the product is used in medical appliances or other types of equipment that affect people's lives, sufficient safety-related evaluations and preparations must be made in advance, and the product or the type of equipment into which the product is assembled must be used under the full responsibility of the user.
- If the product is used in types of equipment that have a strong social and public impact, sufficient prior evaluations and safety-related evaluations and preparations must be made, and the product or the type of equipment into which the product is assembled must be used under the full responsibility of the user.
- The product is not designed to be used in a car or a ship. When using the product in an environment with vibration, such as in a car or a ship, use it at your own discretion only after deploying sufficient safety measures and making prior evaluations.
- Connect all wires properly and securely. Failure to do so may result in fire, burns, or electrical shock.
- Do not use this product in a location where there is flammable gas. Otherwise, it may result in fire, burns, or bodily injury.
- Only use the product integrated with another device or system. Failure to do so may result in burns or electrical shock.
- Do not touch the product while it is operating. Otherwise, it may result in burns or electrical shock.
- Turn off the power and stop using the product immediately if you notice any sparks, smoke, odd odors, sounds, or anything unusual during operation. Failure to do so may result in fire, bodily injury, or electrical shock.
- Never allow the product to fall, topple over, or otherwise be subjected to excessive shocks when moving it. Otherwise, it may result in product failure.
- The product should be handled only by personnel with sufficient training and knowledge and under the full responsibility of the user.
- Never attempt to disassemble, repair, or alter the product in any way. Failure to do so may result in fire, bodily injury, or electrical shock.

### **Caution**

#### Handling

- Discharge static electricity from your body before handling the product. In addition, avoid packaging or covering the product with materials which generate static electricity. Contact with static electricity may result in product failure.
- Do not touch solder joints or pins. Otherwise, it may result in bodily injury.
- Installation, placement, connections, wiring, or relocation of the product should be performed by knowledgeable or correctly licensed personnel. Never perform such work while the product is on. Failure to do so may result in bodily injury, fire, burns, or electrical shock.
- Never allow yourself to come into contact with the ends of wires or plugs when measuring insulation resistance or dielectric strength voltage. Otherwise, it may result in electrical shock.
- Never attempt to disassemble or alter the product in any way. Doing so may invalidate any warranties concerning the functions or performance of the product, and may also result in fire, burns, bodily injury, or electrical shock.

#### Instruction

- Do not touch the product for a period after the power has been turned off as it may still be hot. Otherwise, it may result in burns.
- Take measures to protect the device from potential damage caused by the product stopping during operation.
- Never use the product at voltages, temperatures, or any other settings which exceed those given in the product specifications. Otherwise, it may result in substandard operation, failure, fire, bodily injury, or electrical shock.
- Never remove the product nameplate or install the product so that the identification cannot be seen after installation. Otherwise, it may result in the product being improperly used, and subsequently result in fires.
- Do not turn the power supply ON/OFF on a ground wire. Otherwise, it may result in product failure.
- Do not apply excessive force to the product while it is operating. Otherwise, it may result in product failure.
- If you install and use the product in a car or a ship, we shall not be responsible for any faults caused by the environment of the car or ship in which the product is installed.

#### Installation

- When fixing the product into place, be sure to take into consideration the product's weight and all other relevant factors. Failure to do so may result in the product or its parts falling, resulting in bodily injury or device failure.
- Never install or remove the product while it is wired.
- When fixing the product with screws, ensure correct tightening torque. If the tightening torque is over the recommended values, the product structure may deform or break.
- Install the product carefully without touching conductors or other electrical components. Touching these components may result in device failure, product failure, or product malfunction.
- Take proper precautions against static electricity when making electrical connections. Failure to do so may result in device or product failure.
- Make electrical connections properly. Failure to do so may result in device failure, product failure, or product malfunction.
- Ensure that wires are not allowed to short-circuit. Failure to do so may result in device failure, product failure, or product malfunction.

#### Operating environment

- Do not use or store the product where it is exposed to flammable or corrosive gas, water or oil splashes, dust or humidity, condensation, radioactive rays or direct sunlight, salty air or saltwater, or where the product may be contaminated by corrosive materials such as sulfurous water, sulfurous volcanic ash, organic solvents, acidic chemicals, alkali chemicals, nuclear fuel materials, or other hazardous substances. If it is used or stored in such places or environments, there is the possibility that a fire may occur, the product may malfunction or its performance may deteriorate.
- Do not use or store the product in locations and environments where it could be constantly exposed to vibrations, strong shocks, magnetic or electromagnetic noise, or in which electromagnetic noise overlaps into power voltage. Otherwise, it may result in product failure.
- Do not use or store the product in environments subject to sudden changes in temperature and humidity. Otherwise, it may result in product failure.

#### Maintenance

- Only certified personnel with sufficient training and knowledge should perform maintenance and inspections. Otherwise, it may result in fire, burns, bodily injury, or electrical shock.
- Perform maintenance or inspections while the product is off. Otherwise, it may result in fire, burns, bodily injury, or electrical shock.
- Never use gasoline, paint thinner, benzene, or any other organic solvents to clean the product. Otherwise, it may result in product deformation or substandard operation.