



Chipsmall Limited consists of a professional team with an average of over 10 year of expertise in the distribution of electronic components. Based in Hongkong, we have already established firm and mutual-benefit business relationships with customers from,Europe,America and south Asia,supplying obsolete and hard-to-find components to meet their specific needs.

With the principle of “Quality Parts,Customers Priority,Honest Operation,and Considerate Service”,our business mainly focus on the distribution of electronic components. Line cards we deal with include Microchip,ALPS,ROHM,Xilinx,Pulse,ON,Everlight and Freescale. Main products comprise IC,Modules,Potentiometer,IC Socket,Relay,Connector.Our parts cover such applications as commercial,industrial, and automotives areas.

We are looking forward to setting up business relationship with you and hope to provide you with the best service and solution. Let us make a better world for our industry!



Contact us

Tel: +86-755-8981 8866 Fax: +86-755-8427 6832

Email & Skype: info@chipsmall.com Web: www.chipsmall.com

Address: A1208, Overseas Decoration Building, #122 Zhenhua RD., Futian, Shenzhen, China



San Ace 92W 9WL type

Splash Proof Fan

Features

High Airflow, High Static Pressure, and Long Service Life

This fan features a maximum airflow of 3.70 m³/min, maximum static pressure of 430 Pa, and service life as long as 100,000 hours.⁽¹⁾
The maximum airflow has increased by 68% compared with our current model⁽²⁾.

Water and Dust Resistance

Its IP68-rated⁽³⁾ water and dust protection ensures stable fan operation even in harsh environments.

High Energy Efficiency and Low Noise

The PWM control function enables the external control of fan speed, contributing to lowering noise and improving energy efficiency of devices.

- (1) The values are for 9WL09□□P1H□□□ models, where □'s are wildcard characters.
 (2) Current model: *San Ace 92W* 9WL type 92 × 92 × 25 mm Splash Proof Fan (model no. 9WL0912P4J001).
 (3) The degree of protection (IP code) is defined by IEC (International Electrotechnical Commission) 60529 as below.
- IP68:
- Completely protected against dust
 - Protected against submersion in water



92 × 92 × 38 mm



Specifications

The models listed below **have pulse sensors with PWM control function.**

Model no.	Rated voltage [V]	Operating voltage range [V]	PWM duty cycle* [%]	Rated current [A]	Rated input [W]	Rated speed [min ⁻¹]	Max. airflow [m ³ /min] [CFM]	Max. static pressure [Pa] [inchH ₂ O]	SPL [dB(A)]	Operating temperature [°C]	Expected life [h]		
9WL0912P1H001	12	10.2 to 13.2	100	1.9	22.8	9000	3.70 130.6	430 1.72	61	-20 to +70	100000/60°C		
			20	0.13	1.56	2700	1.11 39.1	48.0 0.19	30				
9WL0912P1F001			100	0.95	11.4	7000	2.90 102.4	263 1.05	55				
			20	0.10	1.20	2000	0.83 29.3	26.3 0.10	22				
9WL0924P1H001	24	20.4 to 26.4	100	0.95	22.8	9000	3.70 130.6	430 1.72	61				
			20	0.07	1.68	2700	1.11 39.1	48.0 0.19	30				
			9WL0924P1F001	100	0.5	12	7000	2.90 102.4	263 1.05			55	
20				0.06	1.44	2000	0.83 29.3	26.3 0.10	22				
9WL0948P1H601			48	40.8 to 52.8	100	0.48	23.04	9000	3.70 130.6			430 1.72	61
					20	0.05	2.4	2700	1.11 39.1			48.0 0.19	30
9WL0948P1F601	100	0.24			11.52	7000	2.90 102.4	263 1.05	55				
	20	0.05			2.4	2000	0.83 29.3	26.3 0.10	22				

* PWM frequency: 25 kHz. Fan does not rotate when PWM duty cycle is 0%.

Models with the following sensor specifications are also available as options: **Without Sensor** **Lock sensor**

Common Specifications

- Material Frame: Aluminum (Black coating), Impeller: Plastic (Flammability: UL 94V-1)
- Expected life See the table below.
(L10 life: 90% survival rate for continuous operation in indoor free air at 60°C, rated voltage)
- Motor protection system Current blocking function and reverse polarity protection
- Dielectric strength 50/60 Hz, 500 VAC, for 1 minute (between lead wire conductors and frame)
- Sound pressure level (SPL) At 1 m away from the air inlet
- Operating temperature Refer to specifications (Non-condensing)
- Storage temperature -30 to +70°C (Non-condensing)
- Lead wire ⊕ Red ⊖ Black Sensor Yellow Control Brown
- Mass Approx. 300 g

Airflow - Static Pressure Characteristics

- PWM duty cycle

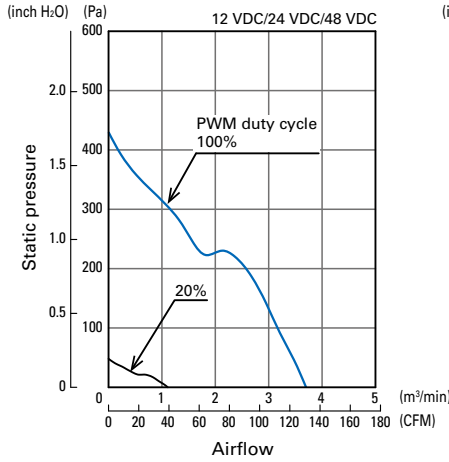

9WL0912P1H001
9WL0924P1H001
9WL0948P1H601

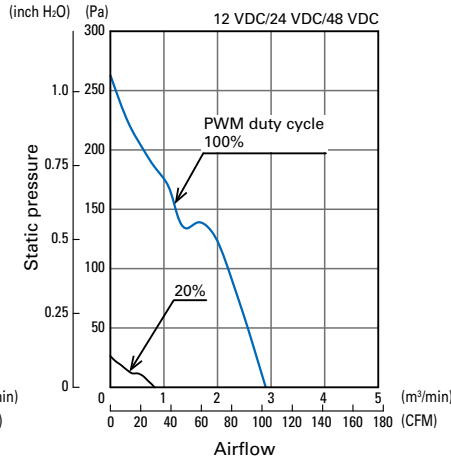

9WL0912P1F001
9WL0924P1F001
9WL0948P1F601

- Operating voltage range

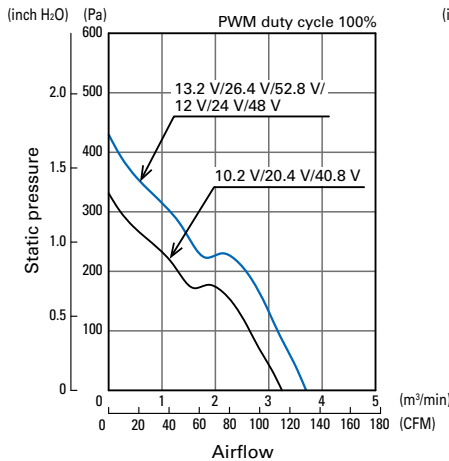

9WL0912P1H001
9WL0924P1H001
9WL0948P1H601

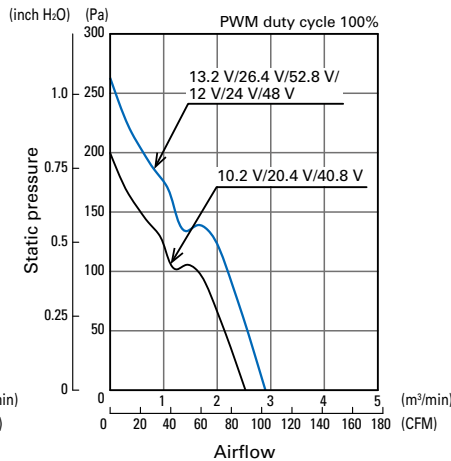

9WL0912P1F001
9WL0924P1F001
9WL0948P1F601

PWM Duty - Speed Characteristics Example

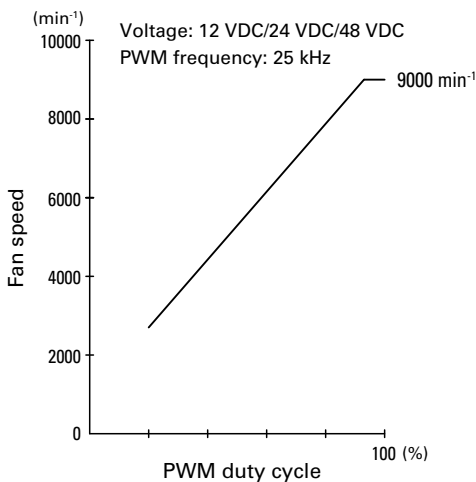

9WL0912P1H001
9WL0924P1H001
9WL0948P1H601

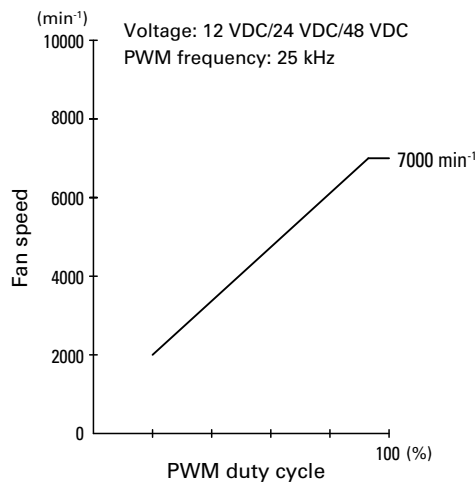

9WL0912P1F001
9WL0924P1F001
9WL0948P1F601

PWM Input Signal Example

Input signal waveform

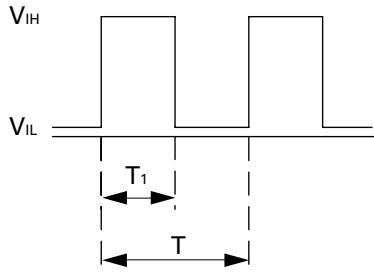

$V_{IH} = 4.75 \text{ to } 5.25 \text{ V}$ $V_{IL} = 0 \text{ to } 0.4 \text{ V}$
 PWM duty cycle (%) = $\frac{T_1}{T} \times 100$ PWM frequency 25 (kHz) = $\frac{1}{T}$
 Current source (I_{source}) = 1 mA max. (when control voltage is 0 V)
 Current sink (I_{sink}) = 1 mA max. (when control voltage is 5.25 V)
 Control terminal voltage = 5.25 V max. (when control terminal is open)

When the control terminal is open, fan speed is the same as when PWM duty cycle is 100%.
 Either TTL input, open collector or open drain can be used for PWM control input signal.

Example of Connection Schematic

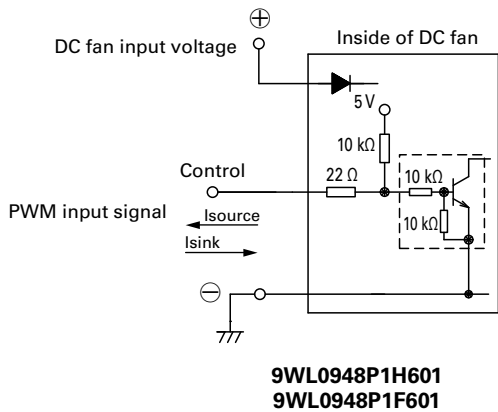
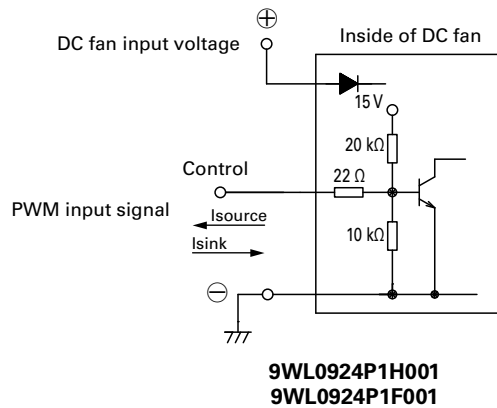
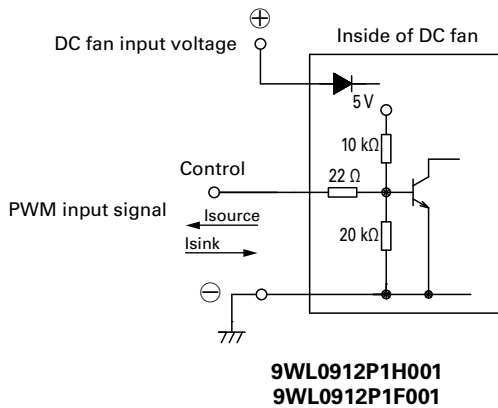

Specifications for Pulse Sensors

Output circuit: Open collector

Inside of DC fan

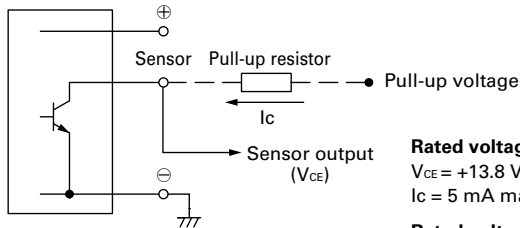

Rated voltage 12 V fan
 $V_{CE} = +13.8 \text{ V max.}$
 $I_c = 5 \text{ mA max. [} V_{OL} = V_{CE} \text{ (SAT)} = 0.6 \text{ V max.]}$

Rated voltage 24 V fan
 $V_{CE} = +30 \text{ V max.}$
 $I_c = 10 \text{ mA max. [} V_{OL} = V_{CE} \text{ (SAT)} = 0.6 \text{ V max.]}$

Rated voltage 48 V fan
 $V_{CE} = +60 \text{ V max.}$
 $I_c = 10 \text{ mA max. [} V_{OL} = V_{CE} \text{ (SAT)} = 0.6 \text{ V max.]}$

Output waveform (Need pull-up resistor)

In case of steady running

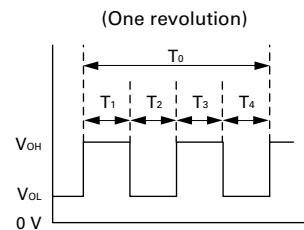

$T_{1 \text{ to } 4} \doteq (1/4) T_0$
 $T_{1 \text{ to } 4} \doteq (1/4) T_0 = 60/4N \text{ (s)}$
 $N = \text{Fan speed (min}^{-1}\text{)}$

Dimensions (unit: mm)

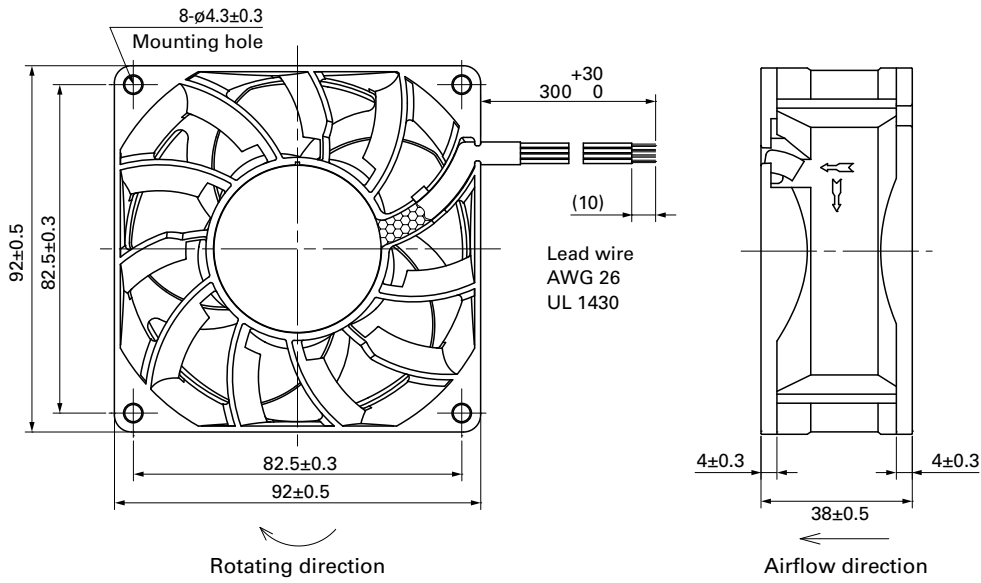

Reference Dimensions of Mounting Holes and Vent Opening (unit: mm)

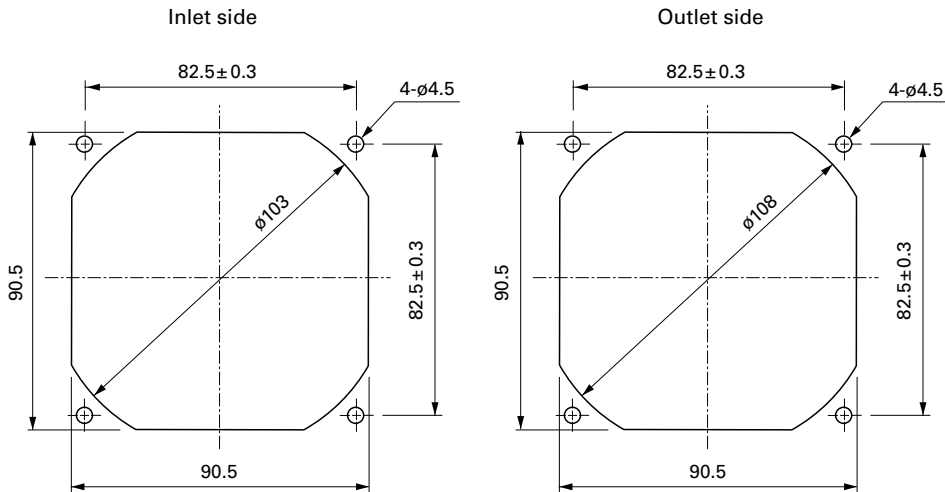

Notice

- Please read the "Safety Precautions" on our website before using the product.
- The products shown in this catalog are subject to Japanese Export Control Law. Diversion contrary to the law of exporting country is prohibited.
- For protecting fan bearings against electrolytic corrosion near strong electromagnetic noise sources, we provide effective countermeasures such as Electrolytic Corrosion Proof Fans and EMC guards. Contact us for details.

SANYO DENKI CO., LTD. 3-33-1 Minami-Otsuka, Toshima-ku, Tokyo 170-8451, Japan TEL: +81 3 5927 1020

<https://www.sanyodenki.com>

The names of companies and/or their products specified in this catalog are the trade names, and/or trademarks and/or registered trademarks of such respective companies. "San Ace" is a trademark of SANYO DENKI CO.,LTD.

Specifications are subject to change without notice.

CATALOG No. C1081B003 '18.4