



Chipsmall Limited consists of a professional team with an average of over 10 year of expertise in the distribution of electronic components. Based in Hongkong, we have already established firm and mutual-benefit business relationships with customers from,Europe,America and south Asia,supplying obsolete and hard-to-find components to meet their specific needs.

With the principle of “Quality Parts,Customers Priority,Honest Operation,and Considerate Service”,our business mainly focus on the distribution of electronic components. Line cards we deal with include Microchip,ALPS,ROHM,Xilinx,Pulse,ON,Everlight and Freescale. Main products comprise IC,Modules,Potentiometer,IC Socket,Relay,Connector.Our parts cover such applications as commercial,industrial, and automotives areas.

We are looking forward to setting up business relationship with you and hope to provide you with the best service and solution. Let us make a better world for our industry!



## Contact us

Tel: +86-755-8981 8866 Fax: +86-755-8427 6832

Email & Skype: info@chipsmall.com Web: www.chipsmall.com

Address: A1208, Overseas Decoration Building, #122 Zhenhua RD., Futian, Shenzhen, China



NOTES:

1. MATERIALS AND FINISHES:  
 HOUSING: LCP (UL94V-0)  
 CENTER CONTACT: BRASS, GOLD PLATE  
 GROUND CONTACT: PHOSPHOR BRONZE, SILVER PLATE

2. ELECTRICAL:

- A. IMPEDENCE: 50Ω, NOMINAL  
 B. FREQUENCY RANGE: 0.045 GHz-3GHz (VSWR 1.3 MAX.) 3-6 GHz (VSWR 1.35 MAX)  
 C. OPERATING VOLTAGE: 500 VRMS  
 D. CONTACT RESISTANCE: CENTER CONTACT= 20 mΩ MAX.  
 OUTER CONTACT = 10mΩ MAX.  
 E. DIELECTRIC WITHSTANDING VOLTAGE: 200 VAC FOR 1 MINUTE,  
 CURRENT LEAKAGE 2mA MAX.  
 F. INSULATION RESISTANCE: 500 MEGOHMS MIN.

3. PHYSICAL:

- A. DURABILITY: 20 CYCLES  
 B. TEMPERATURE RANGE: -40°C TO +90°C  
 C. AMMC INTERFACE IS FULLY COMPATIBLE WITH "W.FL" SERIES PRODUCT.  
 D. SUITABLE FOR LEAD-FREE SOLDER REFLOW PROCESS PER 349-50712.

THIRD ANGLE PROJ.

REVISIONS

REV	DESCRIPTION	DATE	ECO	APPR
A	RELEASE TO MFG	5/18/07	46540	CPM
B	ADDED PURCHASING DRAWING, TAPE SPACING HALVED	11/10/14	50214	MJD

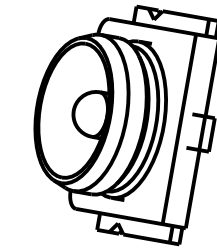

SCALE 15.000

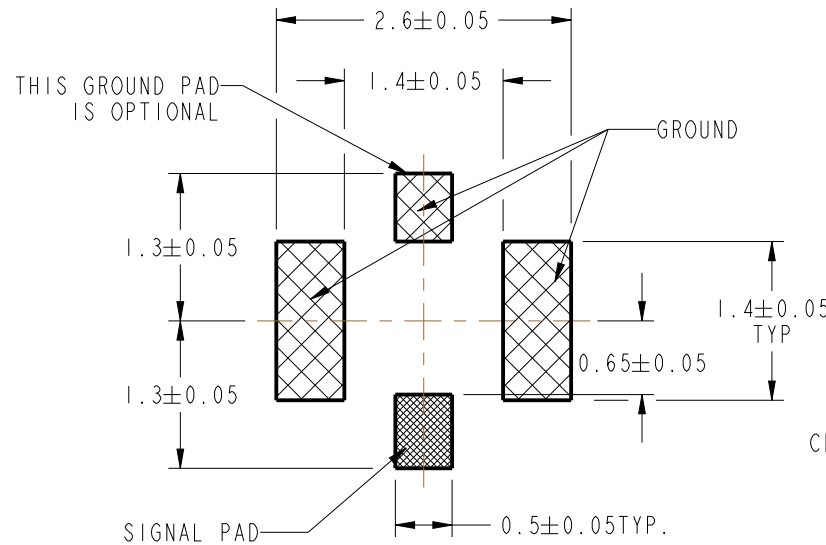

RECOMMENDED PCB PATTERN

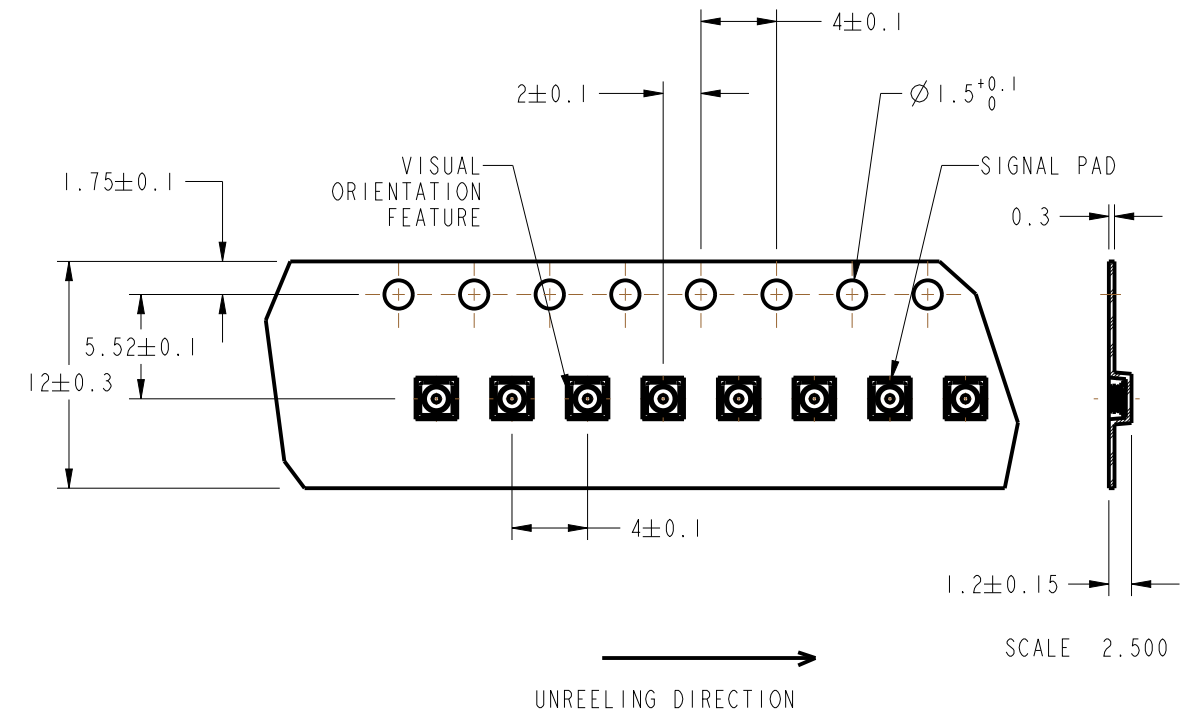
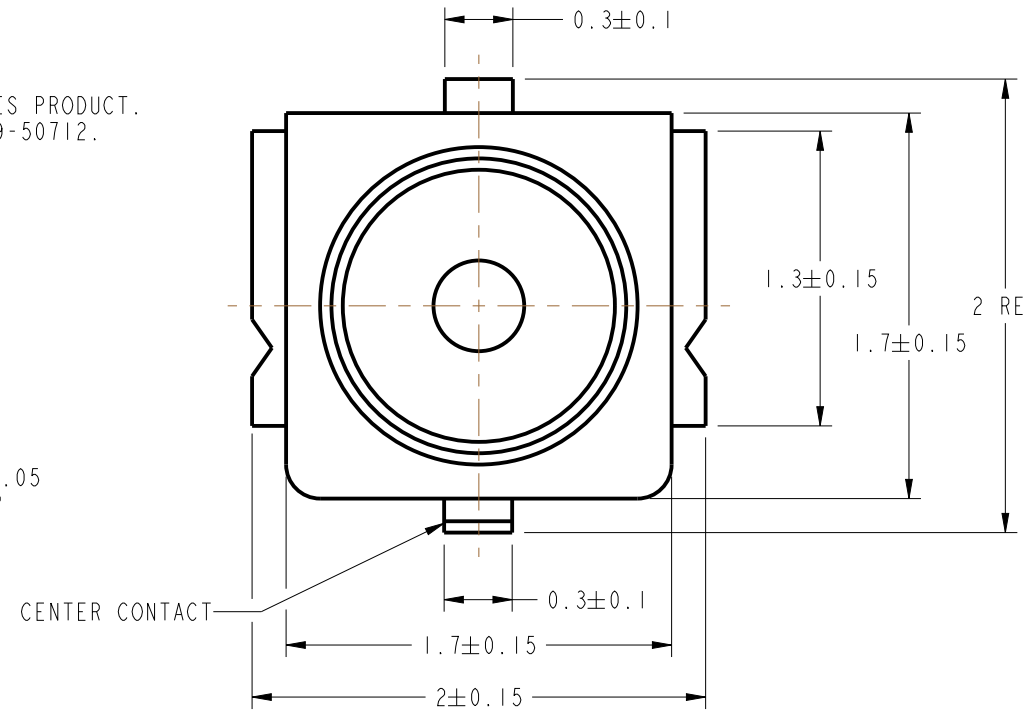

EMBOSSD CARRIER TAPE DIMENSIONS

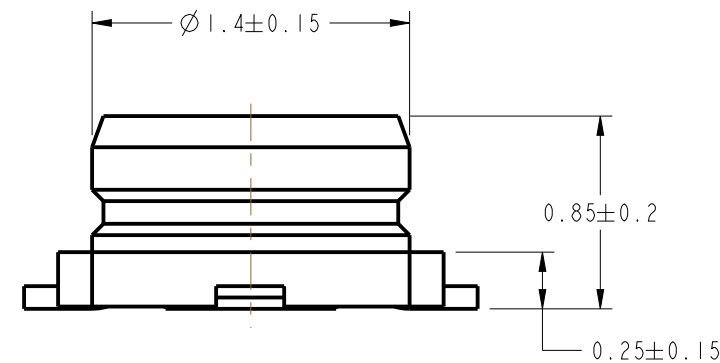

**CUSTOMER OUTLINE DRAWING**

ALL OTHER SHEETS ARE FOR INTERNAL USE ONLY

UNLESS OTHERWISE SPECIFIED, DIMENSIONS ARE IN METRIC AND TOLERANCES ARE:  
 0.5 - 6mm ±0.1mm  
 6 - 30mm ±0.2mm  
 30 - 120mm ±0.3mm  
 ANGLES ±1°

NOTICE - These drawings, specifications, or other data (1) are, and remain the property of Amphenol corp. (2) must be returned upon request; and (3) are confidential and not to be disclosed to any person other than those to whom they are given by Amphenol Corp. the furnishing of these drawings, specifications, or other data by Amphenol Corp., or to any other person to anyone for any purpose is not to be regarded by implication or otherwise in any manner licensing, granting rights to permitting such holder or any other sperson to manufacture, use or sell any product, process or design, patented or otherwise, that may in any way be related to or disclosed by said drawings, specifications, or other data.

MATERIAL	DRAWN H. PARIKH	DATE 10-May-07	TITLE ASSEMBLY AMMC, JACK		Amphenol RF Danbury CT USA, Tainan, Taiwan, Shenzhen, China www.amphenolrf.com	
REFERENCE EAR # 966 AND	ENGINEER H. PARIKH	DATE 10-May-07	APPROVED M. HOYACK		DRAWING NO. A-2JA	
CONFIGURATION LEVEL:	APPROVED M. HOYACK	DATE 5/16/07	SCALE: 30.0:1.0	SHEET 1 OF 2	ITEM NO. A-2JA	
FINISH	Root Folder/AMC/A-2JA		DWG SIZE B	CODE ID 74868	REV B	PART NO. A-2JA