



Chipsmall Limited consists of a professional team with an average of over 10 year of expertise in the distribution of electronic components. Based in Hongkong, we have already established firm and mutual-benefit business relationships with customers from,Europe,America and south Asia,supplying obsolete and hard-to-find components to meet their specific needs.

With the principle of “Quality Parts,Customers Priority,Honest Operation,and Considerate Service”,our business mainly focus on the distribution of electronic components. Line cards we deal with include Microchip,ALPS,ROHM,Xilinx,Pulse,ON,Everlight and Freescale. Main products comprise IC,Modules,Potentiometer,IC Socket,Relay,Connector.Our parts cover such applications as commercial,industrial, and automotives areas.

We are looking forward to setting up business relationship with you and hope to provide you with the best service and solution. Let us make a better world for our industry!



Contact us

Tel: +86-755-8981 8866 Fax: +86-755-8427 6832

Email & Skype: info@chipsmall.com Web: www.chipsmall.com

Address: A1208, Overseas Decoration Building, #122 Zhenhua RD., Futian, Shenzhen, China



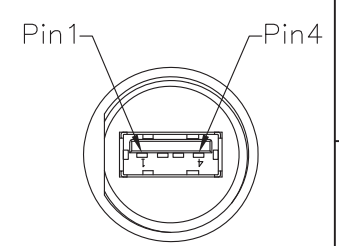
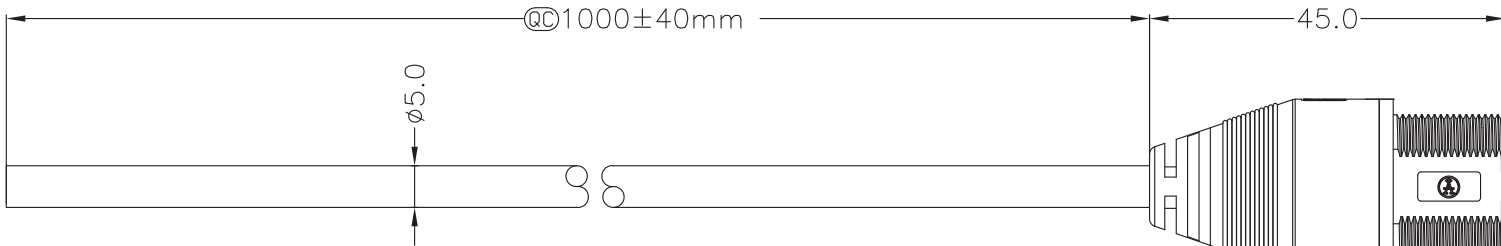

Pin Out

Wire Color	Conn.
Black	4
Green	3
White	2
Red	1
Drain	Shield

Twist

⑤⑥
Color:Black

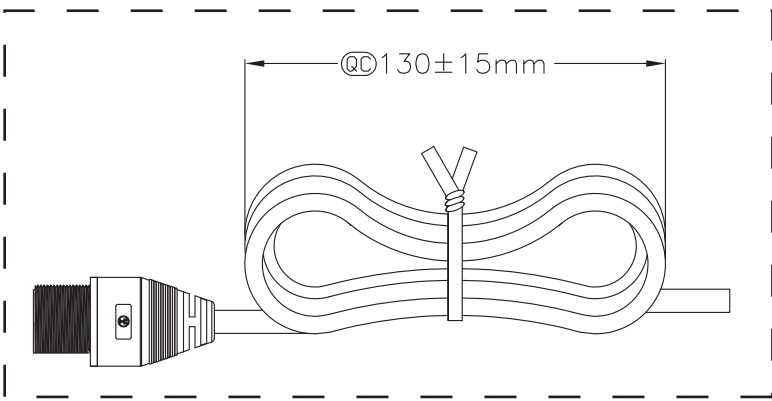
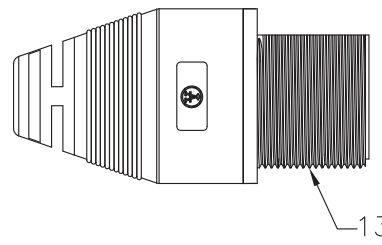

Note:

- IP67 waterproof rated
- Connector: Black, ABS
- USB: USB-A Female solder
- Cable: USB2.0 28AWG*1P+24AWG*2C+AL.My+D+B
UV Resistant, Black, OD=5.0mm

Unit: mm



Scale	Free					Date	Name	
TOLERANCE						Drawn	07.11.11	Chappell
X.X	±0.25					Approved		
X.XX	±0.1							
X.XXX	±0.05							
DIM	TOL							
X.°	±1°							
X.X°	±X°	①	Revised part number/information	11.07.13	Wilson			
Angle	TOL	Id.	Modification	Date	Name			



Title	
Waterproof USB2.0 cable assembly	
A type, Female to Open End, 1 Meter	
ASSMANN WSW-No.	
A-KAB-USBA-FS-1M	
Drawing-No.	rev01
Replace	Sheet 1/1