



Chipsmall Limited consists of a professional team with an average of over 10 year of expertise in the distribution of electronic components. Based in Hongkong, we have already established firm and mutual-benefit business relationships with customers from,Europe,America and south Asia,supplying obsolete and hard-to-find components to meet their specific needs.

With the principle of “Quality Parts,Customers Priority,Honest Operation,and Considerate Service”,our business mainly focus on the distribution of electronic components. Line cards we deal with include Microchip,ALPS,ROHM,Xilinx,Pulse,ON,Everlight and Freescale. Main products comprise IC,Modules,Potentiometer,IC Socket,Relay,Connector.Our parts cover such applications as commercial,industrial, and automotives areas.

We are looking forward to setting up business relationship with you and hope to provide you with the best service and solution. Let us make a better world for our industry!



Contact us

Tel: +86-755-8981 8866 Fax: +86-755-8427 6832

Email & Skype: info@chipsmall.com Web: www.chipsmall.com

Address: A1208, Overseas Decoration Building, #122 Zhenhua RD., Futian, Shenzhen, China



1

2

3

4

5

6

7

A

A

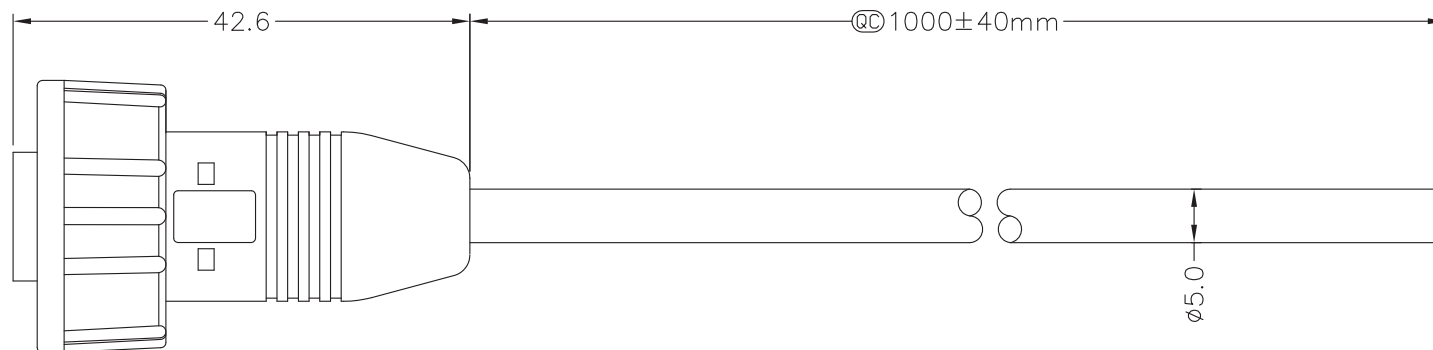
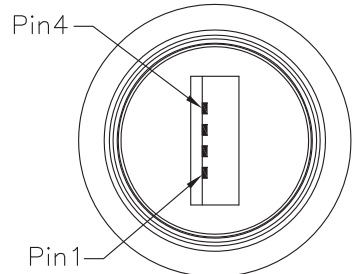

B

B

C

C

Conn.

D

D

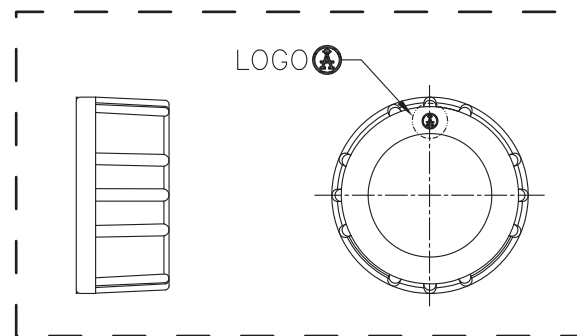
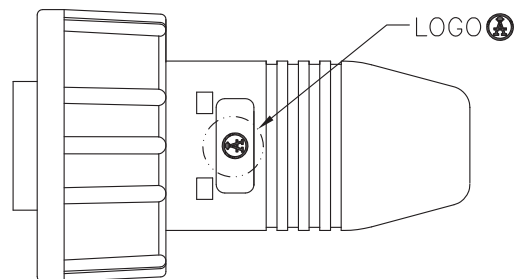

E

E

Pin Out

Wire Color	Conn.
Black(24AWG)	4
Green(28AWG)	3
White(28AWG)	2
Red(24AWG)	1
Drain	Shield

Twist

F

F

Note:

- IP67 waterproof rated
- Connector: USB-A Male solder
- Cable: USB2.0 28AWG*1P+24AWG*2C+AL.My+D+B
UV Resistant, Black, OD=5.0mm

G

G

Scale	Free					Date	Name	
TOLERANCE						Drawn	06.12.11	Chappell
X.X	±0.25					Approved		
X.XX	±0.1							
X.XXX	±0.05							
DIM	TOL							
X.°	±1°							
X.X°	±X°	①	Revised part number/information	11.07.13	Wilson			
Angle	TOL	Id.	Modification	Date	Name			

Title
Waterproof USB2.0 cable assembly
A type, Male to Open End, 1 Meter
ASSMANN WSW-No.
A-KAB-USBA-MS-1M

Drawing-No.
rev01

Replace
Sheet
1/1

H

H

Unit: mm



1840 W. Drake Drive, Suite 101 • Tempe, AZ 85283
Toll Free: 1-877-277-6266 • Email: info@assmann.us

1

2

3

4

5

6

7