



Chipsmall Limited consists of a professional team with an average of over 10 year of expertise in the distribution of electronic components. Based in Hongkong, we have already established firm and mutual-benefit business relationships with customers from,Europe,America and south Asia,supplying obsolete and hard-to-find components to meet their specific needs.

With the principle of “Quality Parts,Customers Priority,Honest Operation,and Considerate Service”,our business mainly focus on the distribution of electronic components. Line cards we deal with include Microchip,ALPS,ROHM,Xilinx,Pulse,ON,Everlight and Freescale. Main products comprise IC,Modules,Potentiometer,IC Socket,Relay,Connector.Our parts cover such applications as commercial,industrial, and automotives areas.

We are looking forward to setting up business relationship with you and hope to provide you with the best service and solution. Let us make a better world for our industry!



Contact us

Tel: +86-755-8981 8866 Fax: +86-755-8427 6832

Email & Skype: info@chipsmall.com Web: www.chipsmall.com

Address: A1208, Overseas Decoration Building, #122 Zhenhua RD., Futian, Shenzhen, China



4		3		2		1		
ITEM	CONNECTOR PART NO.	DESCRIPTION	IPI CHECK	EOR CHECK	Applicable Tooling			
1	See Table 1	DS CONNECTOR			BCD			
2	See Table 1	KR CONNECTOR			TABLE 1			
3	UL1061, 28 AWG	WHITE			ITEM	NUMBER OF CIRCUITS	CONNECTOR PART NO.	ASSEMBLY PART NUMBER

ITEM	NUMBER OF CIRCUITS	CONNECTOR PART NO.	ASSEMBLY PART NUMBER	TOTAL WIRE REQUIRED
1		02DS-8E	A02KR02DS28W152B	304.8
2	2	02KR-8M-P	A02KR02DS28W152B	
1		03DS-8E	A03KR03DS28W152B	457.2
2	3	03KR-8M-P	A03KR03DS28W152B	
1		04DS-8E	A04KR04DS28W152B	609.6
2	4	04KR-8M-P	A04KR04DS28W152B	
1		05DS-8E	A05KR05DS28W152B	762
2	5	05KR-8M-P	A05KR05DS28W152B	
1		06DS-8E	A06KR06DS28W152B	914.4
2	6	06KR-8M-P	A06KR06DS28W152B	
1		07DS-8E	A07KR07DS28W152B	1066.8
2	7	07KR-8M-P	A07KR07DS28W152B	
1		08DS-8E	A08KR08DS28W152B	1219.2
2	8	08KR-8M-P	A08KR08DS28W152B	
1		09DS-8E	A09KR09DS28W152B	1371.6
2	9	09KR-8M-P	A09KR09DS28W152B	
1		10DS-8E	A10KR10DS28W152B	1524
2	10	10KR-8M-P	A10KR10DS28W152B	
1		11DS-8E	A11KR11DS28W152B	1676.4
2	11	11KR-8M-P	A11KR11DS28W152B	
1		12DS-8E	A12KR12DS28W152B	1828.8
2	12	12KR-8M-P	A12KR12DS28W152B	
1		13DS-8E	A13KR13DS28W152B	1981.2
2	13	13KR-8M-P	A13KR13DS28W152B	
1		14DS-8E	A14KR14DS28W152B	2133.6
2	14	14KR-8M-P	A14KR14DS28W152B	
1		15DS-8E	A15KR15DS28W152B	2286
2	15	15KR-8M-P	A15KR15DS28W152B	

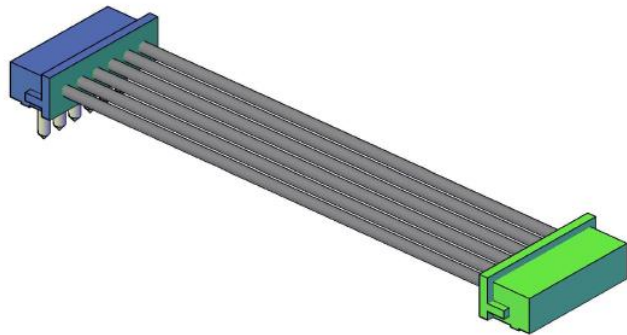
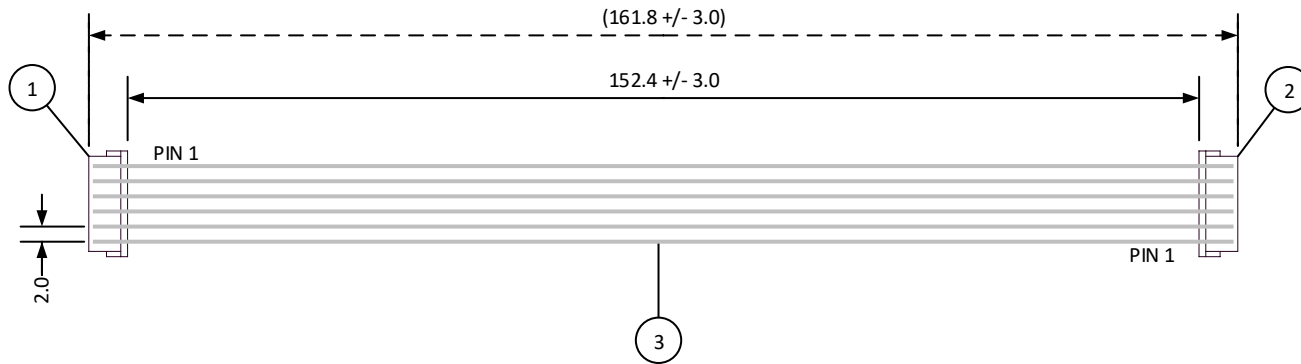

SCALE 1:1		CUSTOMER NAME		CUSTOMER PART NO.	
DIMENSIONS All dimensions are in MM with a tolerance of +/- 3.0 unless otherwise specified.		DESCRIPTION 2.0 mm Pitch DS to KR Standard Catalog Assembly - 6" Overall Length - Pin out: 1 to N			
		DRAWN BY STEVEN PILKINGTON			
CHECKED BY JUSTIN BAKER		ASSEMBLY PART NO. SEE TABLE 1			
REV.		DESCRIPTION		DATE	
				BY	
		DRAWING NO. & REVISION GAM-032		REVISED 3/4/2016	

