



Chipsmall Limited consists of a professional team with an average of over 10 year of expertise in the distribution of electronic components. Based in Hongkong, we have already established firm and mutual-benefit business relationships with customers from,Europe,America and south Asia,supplying obsolete and hard-to-find components to meet their specific needs.

With the principle of “Quality Parts,Customers Priority,Honest Operation,and Considerate Service”,our business mainly focus on the distribution of electronic components. Line cards we deal with include Microchip,ALPS,ROHM,Xilinx,Pulse,ON,Everlight and Freescale. Main products comprise IC,Modules,Potentiometer,IC Socket,Relay,Connector.Our parts cover such applications as commercial,industrial, and automotives areas.

We are looking forward to setting up business relationship with you and hope to provide you with the best service and solution. Let us make a better world for our industry!



Contact us

Tel: +86-755-8981 8866 Fax: +86-755-8427 6832

Email & Skype: info@chipsmall.com Web: www.chipsmall.com

Address: A1208, Overseas Decoration Building, #122 Zhenhua RD., Futian, Shenzhen, China



Chopper-Stabilized, Precision Hall-Effect Latches for Consumer and Industrial Applications

FEATURES AND BENEFITS

- Symmetrical switchpoints
- Resistant to physical stress
- Superior temperature stability
- Output short-circuit protection
- Operation from unregulated supply
- Reverse battery protection
- Solid-state reliability
- Small package size

PACKAGES:

Not to scale

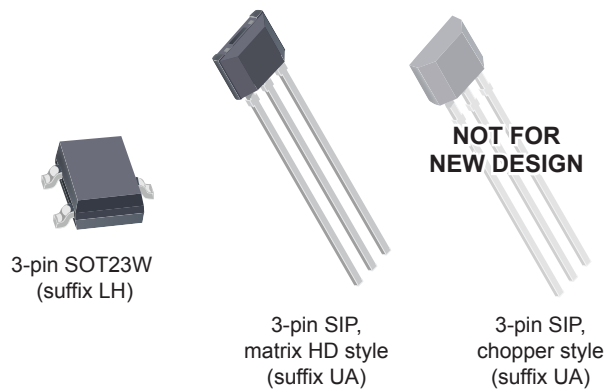

DESCRIPTION

The A3290 and A3291 Hall-effect latches are extremely temperature-stable and stress-resistant sensor ICs, especially suited for operation over extended temperature ranges (up to 125°C). Superior high-temperature performance is made possible through dynamic offset cancellation, which reduces the residual offset voltage normally caused by device package overmolding, temperature dependencies, and thermal stress. The two devices are identical except for their magnetic switchpoints. They are not intended for automotive applications.

Both devices include, on a single silicon chip, a voltage regulator, a Hall voltage generator, a small-signal amplifier, chopper stabilization, a Schmitt trigger, and a short-circuit protected open-drain output to sink up to 25 mA. A south polarity magnetic field of sufficient strength is required to turn the output on. A north polarity field of sufficient strength is necessary to turn the output off. An onboard regulator permits operation with supply voltages in the range of 3 to 24 V.

Two package styles provide a magnetically optimized package for most applications: type LH is a miniature SOT23W low-profile surface-mount package, and type UA is a three-pin ultramini SIP for through-hole mounting. Both packages are lead (Pb) free with 100% matte-tin leadframe plating.

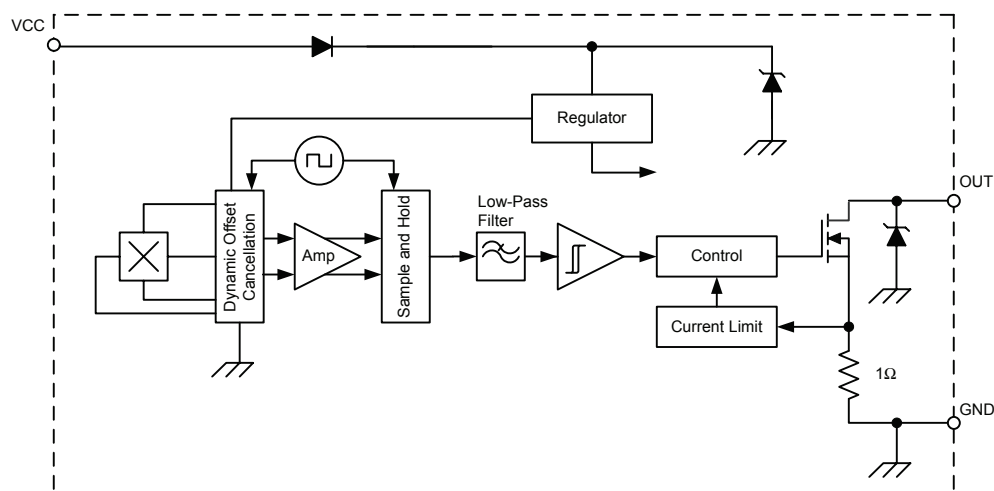

Functional Block Diagram

A3290 and A3291

Chopper-Stabilized, Precision Hall-Effect Latches for Consumer and Industrial Applications

SPECIFICATIONS

SELECTION GUIDE

Part Number	Packing [1]	Package Type	Magnetic Switchpoints [2]	
			Operate, B_{OP} (G)	Release, B_{RP} (G)
A3290KLHLT-T	3000 pieces per 7-in. reel	Surface-mount SOT23W	5 to 50	-50 to -5
A3290KLHLX-T	10000 pieces per 13-in. reel	Surface-mount SOT23W		
A3290KUA-T [3]	500 pieces per bulk bag	Through-hole ultramini SIP	10 to 100	-100 to -10
A3291KLHLT-T	3000 pieces per 7-in. reel	Surface-mount SOT23W		
A3291KLHLX-T	10000 pieces per 13-in. reel	Surface-mount SOT23W		
A3291KUA-T	500 pieces per bulk bag	Through-hole ultramini SIP		



¹ Contact Allegro for additional packing options.

² Algebraic convention used: (+) south polarity, (-) north polarity.

³ The chopper-style UA package is not for new design; the matrix HD style UA package is recommended for new designs.

ABSOLUTE MAXIMUM RATINGS

Characteristic	Symbol	Notes	Rating	Units
Supply Voltage	V_{CC}		26.5	V
Reverse Battery Voltage	V_{RCC}		-30	V
Output Off Voltage	V_{OUT}		26	V
Continuous Output Current	I_{OUT}	Device provides internal current limiting to help protect itself from output short circuits	25	mA
Reverse Output Current	I_{ROUT}		-50	mA
Magnetic Flux Density	B		Unlimited	G
Operating Ambient Temperature	T_A	Range K	-40 to 125	°C
Maximum Junction Temperature	$T_J(max)$		165	°C
Storage Temperature	T_{stg}		-65 to 170	°C

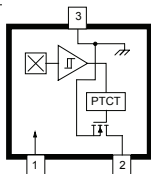

Package LH,
3-Pin SOT23W Pinout
Diagram

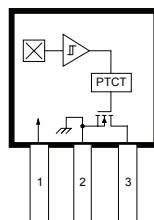

Package UA,
3-Pin SIP Pinout
Diagram

Terminal List

Name	Number		Function
	LH	UA	
VCC	1	1	Power supply
OUT	2	3	Output
GND	3	2	Ground

ELECTRICAL CHARACTERISTICS: Over operating temperature range, unless otherwise noted

Characteristic	Symbol	Test Conditions	Min.	Typ. [1]	Max	Units
Supply Voltage Range [2]	V_{CC}	Operating, $T_J < 165^\circ\text{C}$	3.0	–	24	V
Output Leakage Current	I_{OFF}	$V_{OUT} = 24\text{ V}$, $B < B_{RP}$	–	–	10	μA
Output Saturation Voltage	$V_{OUT(SAT)}$	$I_{OUT} = 20\text{ mA}$, $B > B_{OP}$	–	185	500	mV
Output Current Limit	I_{ON}	$B > B_{OP}$	30	–	60	mA
Power-On Time	t_{PO}	$V_{CC} > 4.2\text{ V}$	–	–	50	μs
Chopping Frequency	f_C		–	800	–	kHz
Output Rise Time	t_R	$R_{LOAD} = 820\ \Omega$, $C_{LOAD} = 20\text{ pF}$	–	0.2	2.0	μs
Output Fall Time	t_F	$R_{LOAD} = 820\ \Omega$, $C_{LOAD} = 20\text{ pF}$	–	0.1	2.0	μs
Supply Current	I_{CC}	$B < B_{RP}$, $V_{CC} = 12\text{ V}$	–	3.0	8.0	mA
		$B > B_{OP}$, $V_{CC} = 12\text{ V}$	–	4.0	8.0	mA
Reverse Battery Current	I_{RCC}	$V_{RCC} = -20\text{ V}$	–	–	-5.0	mA
Zener Voltage	$V_Z + V_D$	$I_{CC} = 15\text{ mA}$, $T_A = 25^\circ\text{C}$	28	–	–	V
Zener Impedance	$Z_Z + Z_D$	$I_{CC} = 15\text{ mA}$, $T_A = 25^\circ\text{C}$	–	50	–	Ω

¹ Typical data at $T_A = 25^\circ\text{C}$, 12 V.

² Maximum V_{CC} must be derated for power dissipation and junction temperature. See application information.

MAGNETIC CHARACTERISTICS [3]: Over V_{CC} range, unless otherwise noted

Characteristic	Symbol	Test Conditions	Min.	Max.	Units	
Operate Point [4]	B_{OP}	A3290	$T_A = 25^\circ\text{C}$ and $T_{A(max)}$	5	50	G
			$T_A = -40^\circ\text{C}$	5	50	G
		A3291	$T_A = 25^\circ\text{C}$ and $T_{A(max)}$	10	100	G
			$T_A = -40^\circ\text{C}$	10	100	G
Release Point [5]	B_{RP}	A3290	$T_A = 25^\circ\text{C}$ and $T_{A(max)}$	-50	-5	G
			$T_A = -40^\circ\text{C}$	-50	-5	G
		A3291	$T_A = 25^\circ\text{C}$ and $T_{A(max)}$	-100	-10	G
			$T_A = -40^\circ\text{C}$	-100	-10	G
Hysteresis ($B_{OP} - B_{RP}$)	B_{HYS}	A3290	$T_A = 25^\circ\text{C}$ and $T_{A(max)}$	10	100	G
			$T_A = -40^\circ\text{C}$	–	100	G
		A3291	$T_A = 25^\circ\text{C}$ and $T_{A(max)}$	20	200	G
			$T_A = -40^\circ\text{C}$	–	200	G

³ The positive polarity symbol (+) indicates south magnetic field, and the negative polarity symbol (–) indicates north magnetic field.

⁴ Required polarity observed and transition of magnetic gradient through B_{OP} . See functional description.

⁵ Required polarity observed and transition of magnetic gradient through B_{RP} after B_{OP} . See functional description.

THERMAL CHARACTERISTICS: May require derating at maximum conditions; see application information

Characteristic	Symbol	Test Conditions [1]	Value	Units
Package Thermal Resistance	$R_{\theta JA}$	Package LH, 1-layer PCB with copper limited to solder pads	228	$^{\circ}\text{C}/\text{W}$
		Package LH, 2-layer PCB with 0.463 in. ² of copper area each side connected by thermal vias	110	$^{\circ}\text{C}/\text{W}$
		Package UA, 1-layer PCB with copper limited to solder pads	165	$^{\circ}\text{C}/\text{W}$

¹ Additional thermal information available on Allegro website.

Power Derating Curve

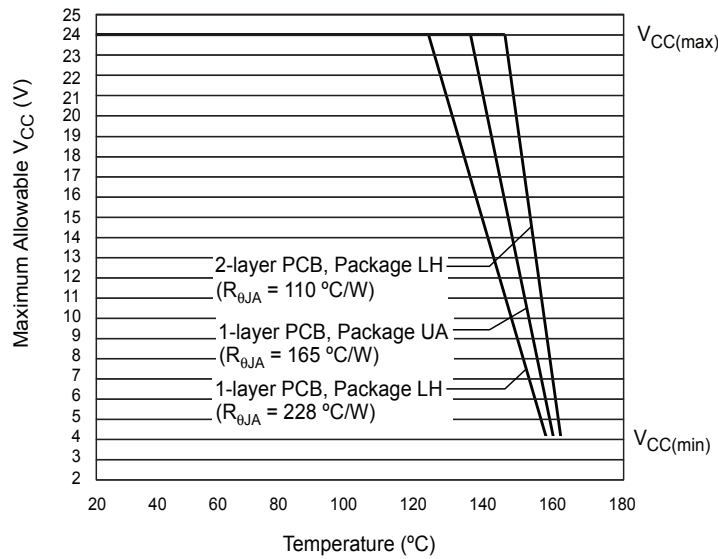

Power Dissipation versus Ambient Temperature

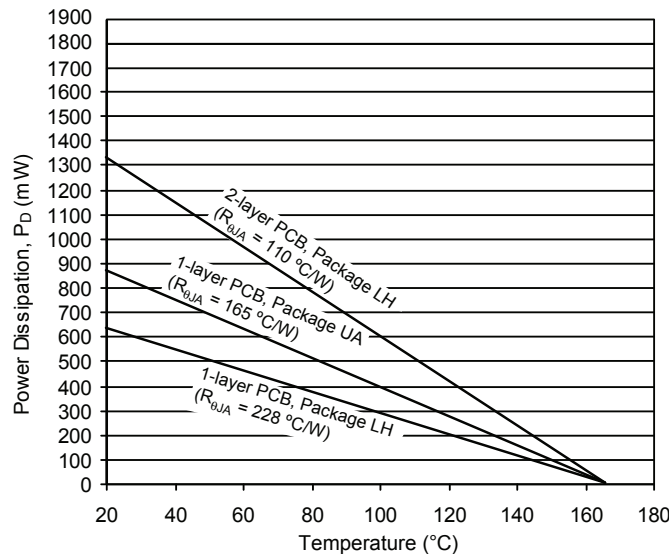

FUNCTIONAL DESCRIPTION

Chopper-Stabilized Technique

The Hall element can be considered as a resistor array similar to a Wheatstone bridge. A basic circuit is shown in Figure 1, demonstrating the effect of the magnetic field flux density (B) impinging on the Hall element. When using Hall-effect technology, a limiting factor for switchpoint accuracy is the small signal voltage (V_{HALL}) developed across the Hall element. This voltage is disproportionately small relative to the offset that can be produced at the output of the Hall device, caused by device overmolding, temperature dependencies, and thermal stress.

A large portion of the offset is a result of the mismatching of these resistors. The A3290 and A3291 use a dynamic offset cancellation technique, with an internal high-frequency clock, to reduce the residual offset. The chopper-stabilizing technique cancels the mismatching of the resistor circuit by changing the direction of the current flowing through the Hall element (refer to Figure 2). To do so, CMOS switches and Hall voltage measurement taps are used, while maintaining V_{HALL} signal that is induced by the external magnetic flux.

The signal is then captured by a sample-and-hold circuit and further processed using low-offset bipolar circuitry. This technique produces devices that have an extremely stable quiescent Hall output voltage, are immune to thermal stress, and have precise

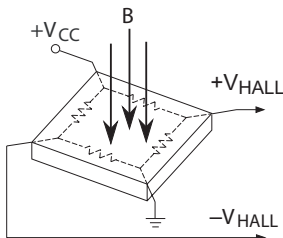

Figure 1: Hall Element, Basic Circuit Operation

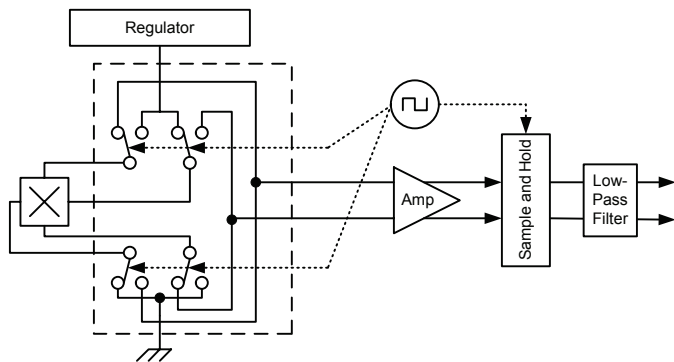

Figure 2: Chopper Stabilization Circuit (Dynamic Quadrature Offset Cancellation)

recoverability after temperature cycling. This technique will also slightly degrade the device output repeatability. A relatively high sampling frequency is used in order to process faster signals.

More detailed descriptions of the circuit operation can be found on the Allegro website, including: Technical Paper STP 97-10, *Monolithic Magnetic Hall Sensing Using Dynamic Quadrature Offset Cancellation*, and Technical Paper STP 99-1, *Chopper-Stabilized Amplifiers with a Track-and-Hold Signal Demodulator*.

Operation

The outputs of the A3290 and A3291 switch low (turn on) when a magnetic field perpendicular to the Hall element transitions through and exceeds the Operate Point threshold (B_{OP}). This is illustrated in Figure 3. After turn-on, the output is capable of sinking 25 mA, and the output voltage reaches $V_{OUT(SAT)}$.

Note that these devices latch; that is, after a south (+) polarity magnetic field of sufficient strength impinging on the branded face of the device turns on the device, the device remains on until the magnetic field is reduced below the Release Point threshold (B_{RP}). At that transition, the device output goes high (turns off). The difference in the magnetic operate and release points is the hysteresis (B_{HYS}) of the device. This built-in hysteresis allows clean switching of the output, even in the presence of external mechanical vibration and electrical noise.

When the devices are powered on, if the ambient magnetic field has an intensity that is between B_{OP} and B_{RP} , the initial output state is indeterminate. The first time that the level of B either rises through B_{OP} , or falls through B_{RP} , however, the correct output state is obtained.

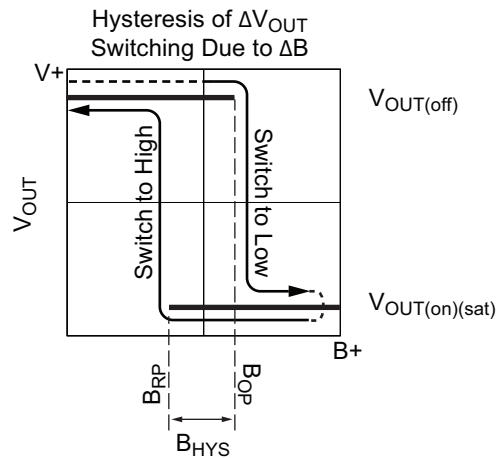

Figure 3: Output Voltage Responds to Sensed Magnetic Flux Density

APPLICATION INFORMATION

It is strongly recommended that an external bypass capacitor be connected (in close proximity to the Hall element) between the supply and ground of the device to reduce both external noise and noise generated by the chopper stabilization technique. This configuration is shown in Figure 4.

The simplest form of magnet that will operate these devices is a ring magnet. Other methods of operation, such as linear magnets, are possible.

The device must be operated below the maximum junction temperature of the device ($T_{J(max)}$). Under certain combinations of peak conditions, reliable operation may require derating supplied power or improving the heat dissipation properties of the application. The Package Thermal Resistance ($R_{\theta JA}$) is a figure of merit

summarizing the ability of the application and the device to dissipate heat from the junction (die), through all paths to the ambient air. Its primary component is the Effective Thermal Conductivity (K) of the printed circuit board, including adjacent devices and traces. Radiation from the die through the device case ($R_{\theta JC}$) is relatively small component of $R_{\theta JA}$. Ambient air temperature (T_A) and air motion are significant external factors, damped by overmolding. Sample power dissipation results are given in the Thermal Characteristics section. Additional thermal data is also available on the Allegro website.

Extensive applications information for Hall-effect devices is available in: *Hall-Effect IC Applications Guide*, Application Note 27701 and *Guidelines for Designing Subassemblies Using Hall-Effect Devices*, Application Note 27703.1.

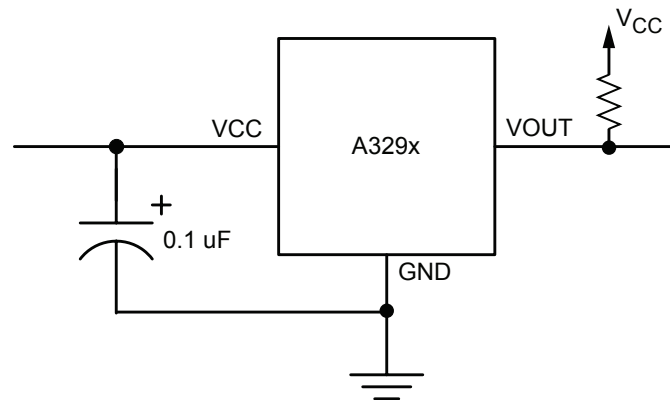

Figure 4: Typical Basic Application Circuit
A bypass capacitor is highly recommended.

CUSTOMER PACKAGE DRAWINGS

For Reference Only – Not for Tooling Use

(Reference DWG-2840)
Dimensions in millimeters – NOT TO SCALE
Dimensions exclusive of mold flash, gate burrs, and dambar protrusions
Exact case and lead configuration at supplier discretion within limits shown

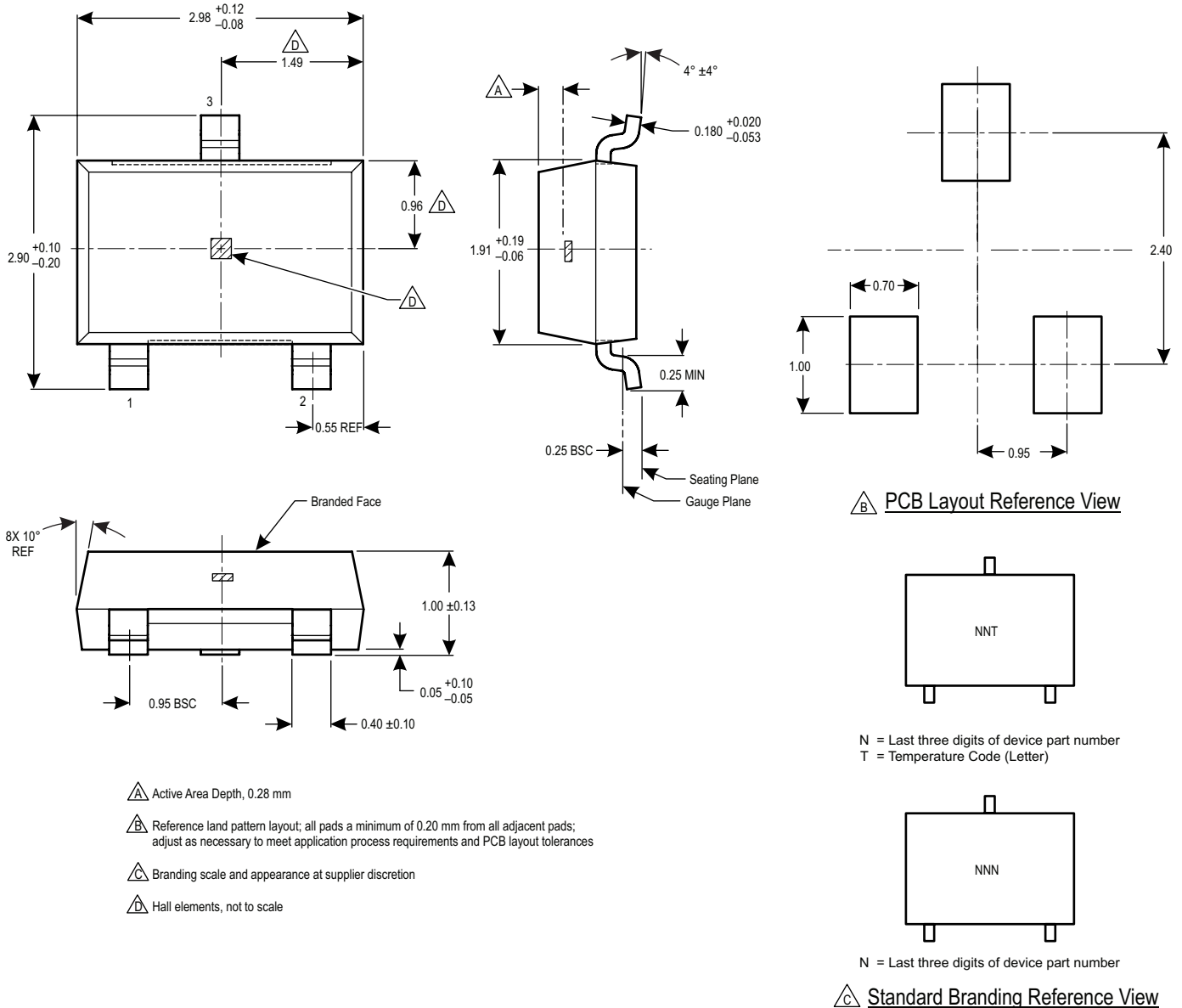

Figure 5: Package LH, 3-Pin SOT23W

For Reference Only – Not for Tooling Use

(Reference DWG-9065)
Dimensions in millimeters – NOT TO SCALE
Dimensions exclusive of mold flash, gate burrs, and dambar protrusions
Exact case and lead configuration at supplier discretion within limits shown

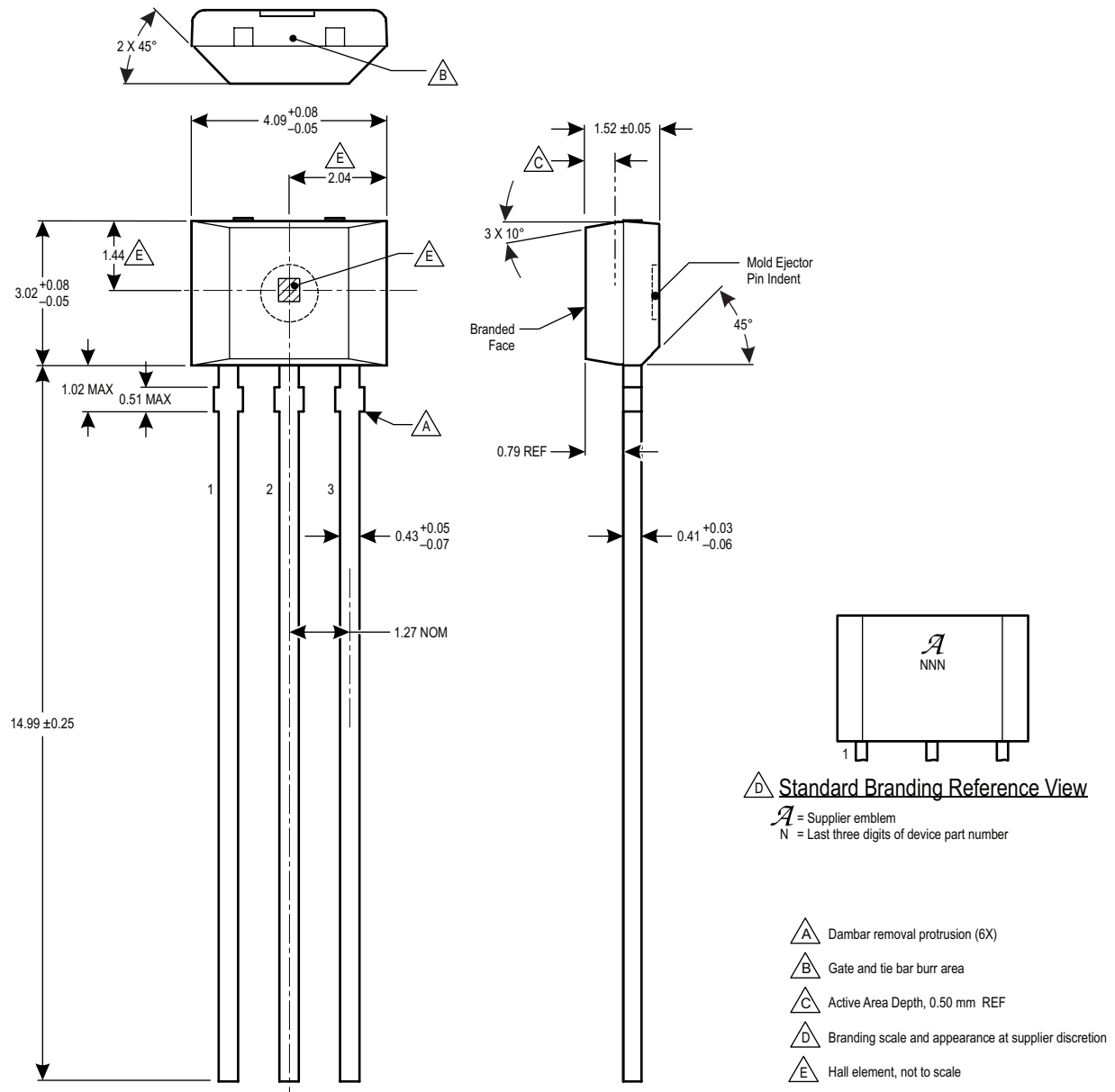

Figure 6: Package UA, 3-Pin SIP, Matrix Style

For Reference Only – Not for Tooling Use

(Reference DWG-9049)

Dimensions in millimeters – NOT TO SCALE

Dimensions exclusive of mold flash, gate burrs, and dambar protrusions
Exact case and lead configuration at supplier discretion within limits shown

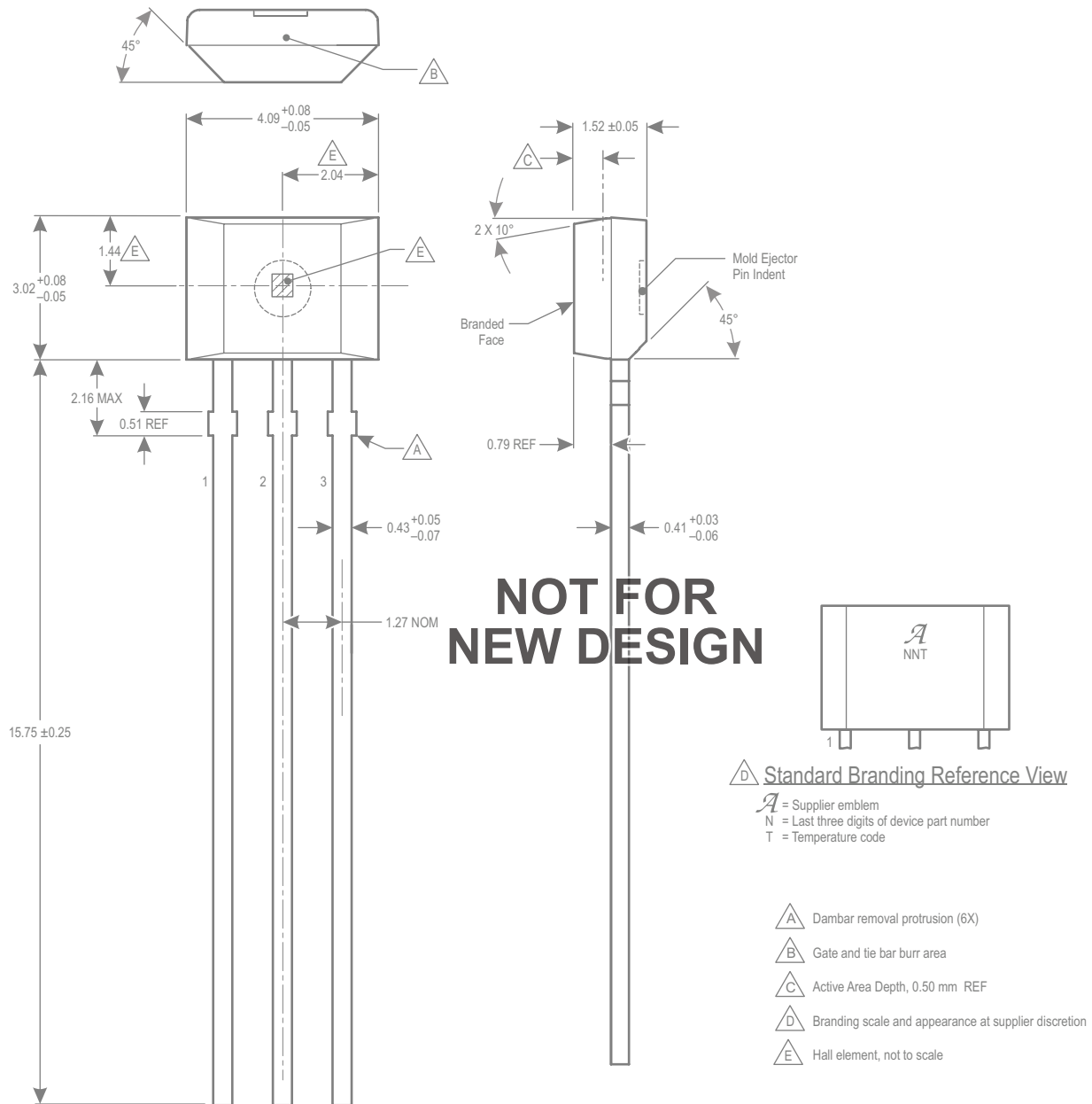

Figure 7: Package UA, 3-Pin SIP, Chopper Style (A3290)

Revision History

Number	Date	Description
11	November 11, 2013	Conform Description
12	January 1, 2015	Added LX option to Selection Guide
13	May15, 2015	Added new package for A3291
14	July 13, 2015	Corrected LH package Active Area Depth value
15	January 12, 2016	Updated Reverse Supply Current test conditions in Electrical Characteristics table
16	October 31, 2016	Chopper-style UA package designated as not for new design

Copyright ©2016, Allegro MicroSystems, LLC

Allegro MicroSystems, LLC reserves the right to make, from time to time, such departures from the detail specifications as may be required to permit improvements in the performance, reliability, or manufacturability of its products. Before placing an order, the user is cautioned to verify that the information being relied upon is current.

Allegro's products are not to be used in any devices or systems, including but not limited to life support devices or systems, in which a failure of Allegro's product can reasonably be expected to cause bodily harm.

The information included herein is believed to be accurate and reliable. However, Allegro MicroSystems, LLC assumes no responsibility for its use; nor for any infringement of patents or other rights of third parties which may result from its use.

For the latest version of this document, visit our website:

www.allegromicro.com

