



Chipsmall Limited consists of a professional team with an average of over 10 year of expertise in the distribution of electronic components. Based in Hongkong, we have already established firm and mutual-benefit business relationships with customers from,Europe,America and south Asia,supplying obsolete and hard-to-find components to meet their specific needs.

With the principle of "Quality Parts,Customers Priority,Honest Operation,and Considerate Service",our business mainly focus on the distribution of electronic components. Line cards we deal with include Microchip,ALPS,ROHM,Xilinx,Pulse,ON,Everlight and Freescale. Main products comprise IC,Modules,Potentiometer,IC Socket,Relay,Connector.Our parts cover such applications as commercial,industrial, and automotives areas.

We are looking forward to setting up business relationship with you and hope to provide you with the best service and solution. Let us make a better world for our industry!



## Contact us

Tel: +86-755-8981 8866 Fax: +86-755-8427 6832

Email & Skype: info@chipsmall.com Web: www.chipsmall.com

Address: A1208, Overseas Decoration Building, #122 Zhenhua RD., Futian, Shenzhen, China







# ITT

Interconnect Solutions  
Cannon, VEAM, BIW



Ensuring soldier safety

in the harshest environments for

**20 years** and over

**500,000** SINCGARS radios



*Engineered for life*

This range of 50 ohm microminiature radio frequency connectors is suitable for both military and commercial equipment operating at frequencies up to 4 GHz (SSMB) and 12.4 GHz (SSMC). They provide a choice of Snap-on (SSMB) or Screw-on (SSMC) and are available for a wide range of flexible cables.

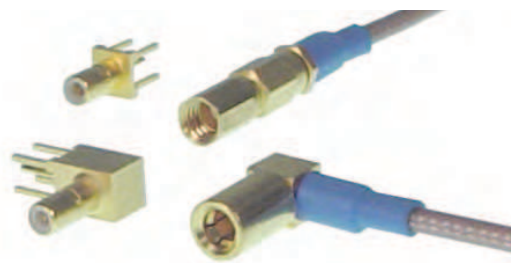

SSMC connectors are used where a positive mechanical engagement is required and where space permits the use of torque wrenches. SSMB connectors are quick disconnect versions of the SSMC and are used in applications where limited space prohibits the use of torque wrenches or when components or modules must be quickly changed to keep down time to a minimum.

**Key Features**

- Small size
- Low mass
- Close packing density
- Used in airborne applications



**Mating Interface**

**SSMB (SNAP-ON)**

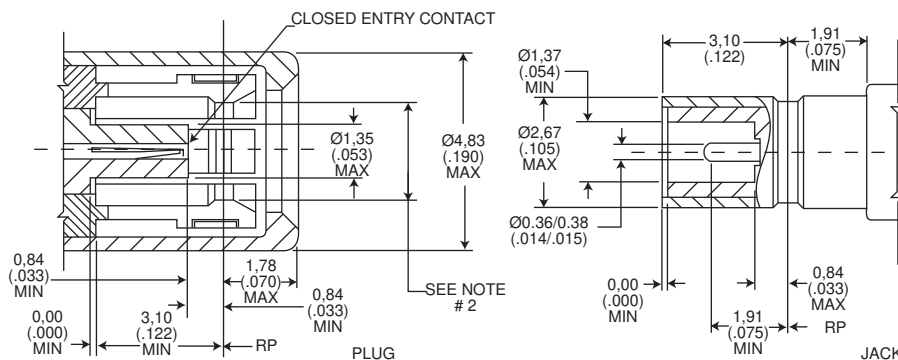

**SSMC (SCREW-ON)**

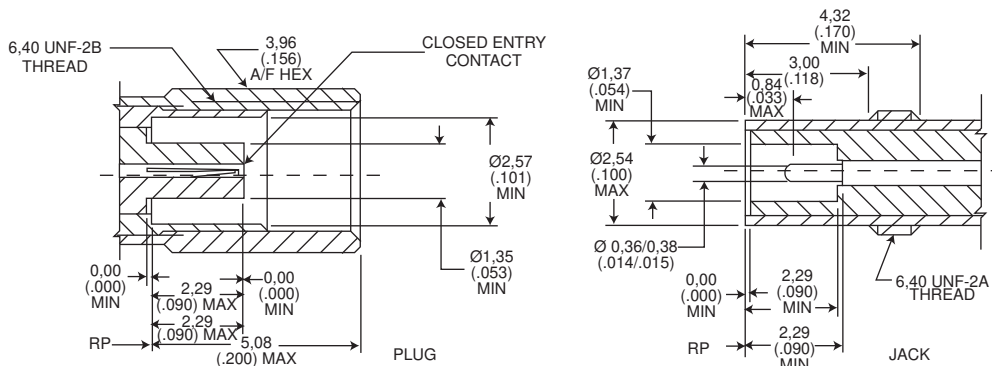

**NOTES**

1) Inside diameter of female contact to meet VSWR, mating characteristics and connector durability, when mated with a 0,36 - 0,38 (.014 - .015) diameter male contact.

2) Must meet the force to engage and disengage when mated with its mating part.

Specifications

ELECTRICAL	Impedance	50Ω																																	
	Frequency Range	SSMB = 0 to 4.0 GHz. SSMC = 0 to 12.4 GHz																																	
	Voltage Rating	At Sea Level = 250 Vrms. at 21km (70k feet) = 60 Vrms																																	
	Insulation Resistance	1000 MΩ minimum																																	
	Contact resistance	Center Contact = 4.0 m Ω maximum initial. 6.0 m Ω maximum after environment Outer Contact = 1.0 m Ω maximum initial. 1.5 m Ω maximum after environment Braid to Body = 1.0 m Ω maximum																																	
	Contact Current Rating	1.0 A dc maximum																																	
	Insertion Loss	0.30 dB maximum @ 1.5 GHz																																	
	RF Leakage	SSMB = -40 dB minimum @ 2 - 3 GHz SSMC = -50 dB minimum @ 2 - 3 GHz																																	
	Voltage Standing Wave Ratio (VSWR) To 12.4 GHz or 80% of upper cut-off frequency of the cable, whichever is lower. Applicable to 50Ω cables only.(F = GHz)	<table border="1"> <thead> <tr> <th rowspan="2"></th> <th colspan="4">Connector Configuration</th> </tr> <tr> <th colspan="2">SSMB</th> <th colspan="2">SSMC</th> </tr> <tr> <td></td> <td>Straight</td> <td>Right Angle</td> <td>Straight</td> <td>Right Angle</td> </tr> </thead> <tbody> <tr> <td>Cable group</td> <td></td> <td></td> <td></td> <td></td> </tr> <tr> <td>RG178/U, 196/U</td> <td>1.25 + .02F</td> <td>1.25 + .03F</td> <td>1.20 + .02F</td> <td>1.20 + .03F</td> </tr> <tr> <td>RG188/U, 316/U</td> <td>1.30 + .02F</td> <td>1.30 + .03F</td> <td>1.25 + .03F</td> <td>1.30 + .02F</td> </tr> </tbody> </table>						Connector Configuration				SSMB		SSMC			Straight	Right Angle	Straight	Right Angle	Cable group					RG178/U, 196/U	1.25 + .02F	1.25 + .03F	1.20 + .02F	1.20 + .03F	RG188/U, 316/U	1.30 + .02F	1.30 + .03F	1.25 + .03F	1.30 + .02F
		Connector Configuration																																	
SSMB		SSMC																																	
	Straight	Right Angle	Straight	Right Angle																															
Cable group																																			
RG178/U, 196/U	1.25 + .02F	1.25 + .03F	1.20 + .02F	1.20 + .03F																															
RG188/U, 316/U	1.30 + .02F	1.30 + .03F	1.25 + .03F	1.30 + .02F																															
MECHANICAL	Engagement Forces	SSMB: Initial = 26.7 N (6 lbs.) max. engagement and 8.9 N(2 lbs.) minimum disengagement. After 500 matings = 26.7 N (6 lbs.) max. engagement and 4.4 N (1 lb.) min. disengagement. SSMC: 0.11 Nm (16 in. oz.) torque max.																																	
	Mating Torque	SSMB: N/A SSMC: 0.2 Nm to 0.23 Nm (28 - 32 in.oz)																																	
	Locknut Torque	0.28 Nm to 0.35 Nm (40 - 50 in. oz)																																	
	Coupling Nut Retention	SSMB: N/A SSMC: 111 N (25 lbs. ) minimum																																	
	Materials	Body, Body Components: Brass, half hard. Male and Female Contacts: Beryllium Copper. Insulators: PTFE. Lockwashers: Phosphor Bronze. Crimp Ferrule: Annealed copper alloy.																																	
ENVIRONMENTAL	Finish/Plating	Center Contacts: Gold plated. Other Metal Parts: Gold or nickel plated to meet the finish and corrosion requirements of MIL-C-39012																																	
	Temperature Rating	-65° C to 165° C																																	
	Corrosion (salt spray)	MIL-STD-202, Method 101, test condition B, 5% salt solution																																	
	Vibration, High Frequency	MIL-STD-202, Method 204, SSMB: test condition B (15 G's). SSMC: test condition D (20 G's)																																	
	Shock	MIL-STD-202, Method 213, SSMB: test condition B, 75 G's @ 6 milliseconds, 1/2 sine. SSMC: test condition C, 100 G's @ 6 milliseconds, 1/2 sine.																																	
GENERAL	Thermal Shock	MIL-STD-202, Method 107, test condition B, except high temperature shall be 85° C. High temperature shall be 200°C for connectors using 200°C cables.																																	
	Connector Durability	500 matings minimum																																	
	Contact Captivation	8,9 N (2 lbs.) minimum axial force.																																	
	Cable Retention	When properly assembled to the compatible single braided coaxial cable, the retention is equal to the breaking strength of the cable.																																	

Body plating options

The following part number suffices can be specified for SSMB and SSMC connectors.

- ...220 gold body
- ...910 nickel body

## PLUGS, JACKS AND RECEPTACLES

### Straight Plug

Part Number	Cable Numbers	A
051 - 424 - 3188220	RG174/U, 316/U	20,01 (.790)
A51 - 424 - 3196220	RG178/U, 196/U	19,33 (.761)

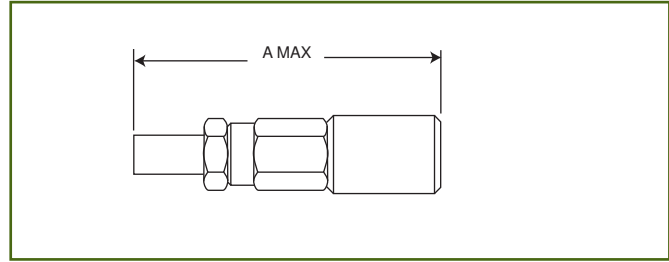

### Right Angle Plug

Part Number	Cable Numbers	A
A51 - 428 - 3188220	RG174/U, 316/U	9,55 (.376)
A51 - 428 - 3196220	RG178/U, 196/U	9,55 (.376)
A51 - 428 - 3875220	RD316	10,16 (.400)

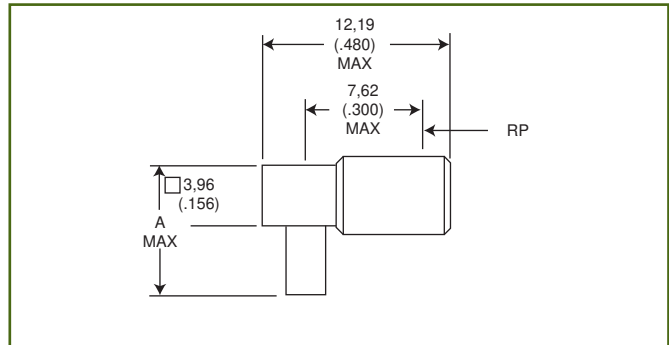

### Bulkhead Jack

Part Number	Cable Numbers	A
051 - 427 - 3188220	RG174/U, 316/U	9,93 (.391)
A51 - 427 - 3196220	RG178/U, 196/U	10,41 (.410)

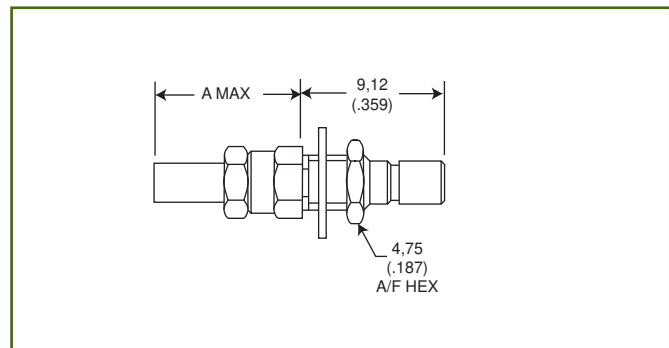

### Bulkhead Receptacle - Rear Mount Mounting Nut Outside Panel

Part Number
051 - 443 - 0000220

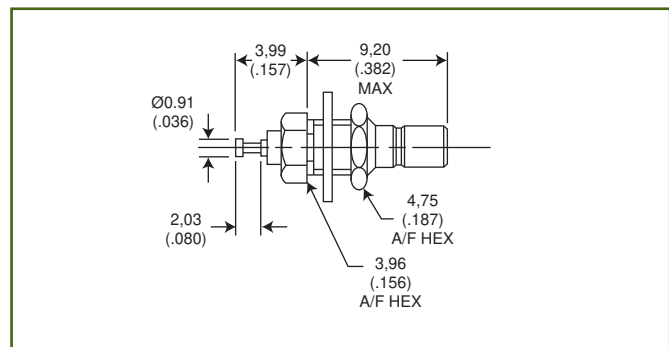



**BULKHEAD AND PRINTED CIRCUIT RECEPTACLES**

Bulkhead Receptacle - Front Mount  
Mount Nut Inside Panel

Part Number
051 - 445 - 0000220

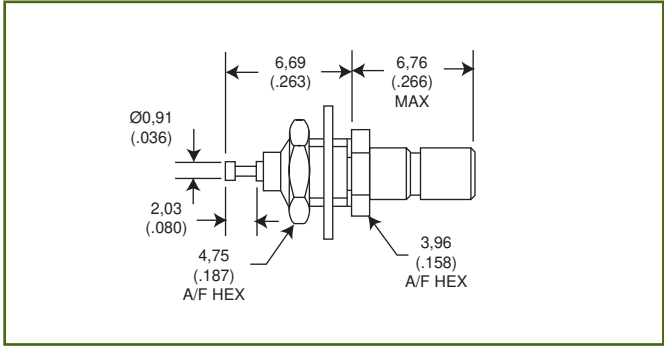

Printed Circuit Receptacle - Straight Jack

Part Number
A51 - 451 - 0000220

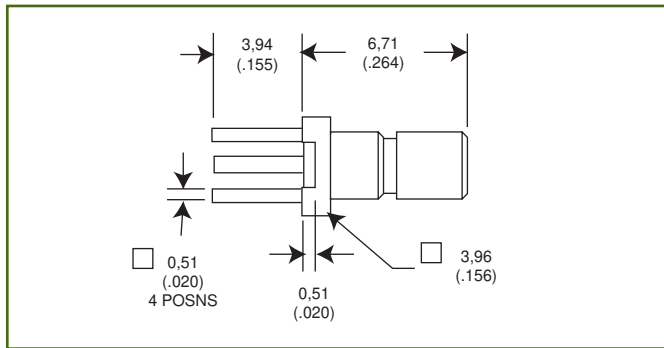

Printed Circuit Receptacle - Straight Plug

Part Number
051 - 452 - 0000220

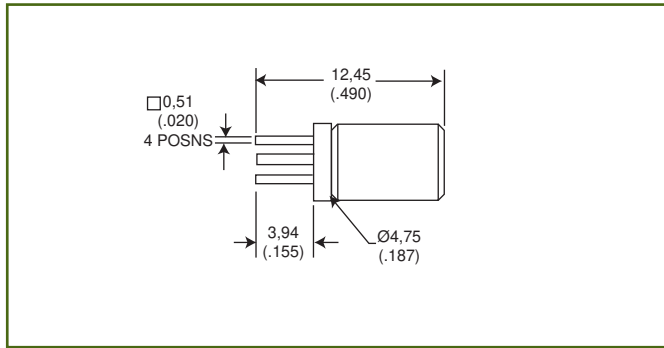

Printed Circuit Receptacle - Right Angle Jack

Part Number
A51 - 453 - 0000220

