



Chipsmall Limited consists of a professional team with an average of over 10 year of expertise in the distribution of electronic components. Based in Hongkong, we have already established firm and mutual-benefit business relationships with customers from,Europe,America and south Asia,supplying obsolete and hard-to-find components to meet their specific needs.

With the principle of “Quality Parts,Customers Priority,Honest Operation,and Considerate Service”,our business mainly focus on the distribution of electronic components. Line cards we deal with include Microchip,ALPS,ROHM,Xilinx,Pulse,ON,Everlight and Freescale. Main products comprise IC,Modules,Potentiometer,IC Socket,Relay,Connector.Our parts cover such applications as commercial,industrial, and automotives areas.

We are looking forward to setting up business relationship with you and hope to provide you with the best service and solution. Let us make a better world for our industry!



## Contact us

Tel: +86-755-8981 8866 Fax: +86-755-8427 6832

Email & Skype: info@chipsmall.com Web: www.chipsmall.com

Address: A1208, Overseas Decoration Building, #122 Zhenhua RD., Futian, Shenzhen, China



---

## *Ionization Smoke Detector with Interconnect*

---

### **Discontinued Product**

These parts are no longer in production. The device should not be purchased for new design applications. Samples are no longer available.

Date of status change: November 2, 2009

#### **Recommended Substitutions:**

---

NOTE: For detailed information on purchasing options, contact your local Allegro field applications engineer or sales representative.

---

*Allegro MicroSystems, Inc. reserves the right to make, from time to time, revisions to the anticipated product life cycle plan for a product to accommodate changes in production capabilities, alternative product availabilities, or market demand. The information included herein is believed to be accurate and reliable. However, Allegro MicroSystems, Inc. assumes no responsibility for its use; nor for any infringements of patents or other rights of third parties which may result from its use.*

---

## Ionization Smoke Detector with Interconnect

### Features and Benefits

- Low average standby current for long battery life
- Interconnect up to 125 detectors
- Piezoelectric horn driver
- Guard outputs for detector input
- Pulse testing for low battery
- Power-on reset (POR)
- Internal reverse battery protection
- Inverted alarm polarity on DETECT IN

### Package: 16-pin DIP (suffix A):

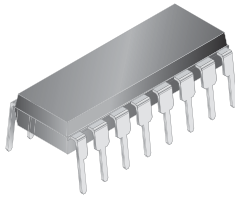

Not to scale

### Description

The A5350 is a low-current, BiCMOS circuit providing all of the required features for an ionization-type smoke detector. A networking capability allows as many as 125 units to be interconnected so that if any unit senses smoke all units will sound their alarm. In addition, special features are incorporated to facilitate alignment and test of the finished smoke detector.

The internal oscillator and timing circuitry keep standby power to a minimum by powering down the device for 1.66 seconds and sensing for smoke for only 10 ms. Every 24 on-off cycles, a check is made for a low battery condition. By substituting other types of sensors or a switch for the ionization detector, this very-low-power device can be used in numerous other battery-operated safety/security applications.

The A5350 is supplied in a low-cost 16-pin dual in-line plastic package (DIP). It is rated for continuous operation over the temperature range of  $-10^{\circ}\text{C}$  to  $60^{\circ}\text{C}$ . The Pb (lead) free version (suffix -T) has 100% matte tin leadframe plating.

### Typical Application

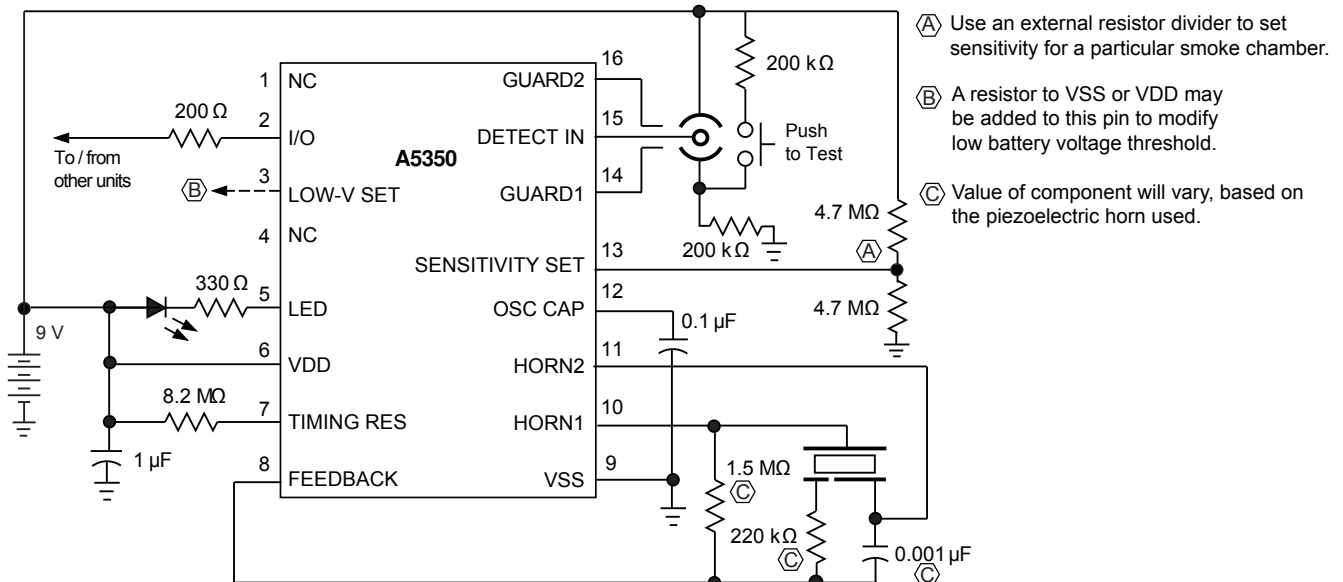



## Selection Guide

Part Number	Pb-Free	Packing
A5350CA-T*	Yes	25 pieces per tube
A5350CA	–	

\*Variant is in production but has been determined to be NOT FOR NEW DESIGN. This classification indicates that sale of the variant is currently restricted to existing customer applications. The variant should not be purchased for new design applications because obsolescence in the near future is probable. Samples are no longer available. Status change: May 4, 2009.

## Absolute Maximum Ratings\*

Characteristic	Symbol	Notes	Rating	Units
Supply Voltage Range	$V_{DD}$	Referenced to $V_{SS}$	–0.5 to 15	V
Input Voltage Range	$V_{IN}$	Referenced to $V_{SS}$	–0.3 to $V_{DD} + 0.3$	V
Reverse Battery Condition Duration	$t_{RBAT}$	10.5 V	20	s
Input Current	$I_{IN}$		10	mA
Operating Ambient Temperature	$T_A$		–10 to 60	°C
Junction Temperature	$T_J(max)$		150	°C
Storage Temperature Range	$T_{stg}$		–55 to 125	°C

\* CAUTION: BiCMOS devices have input static protection but are susceptible to damage when exposed to extremely high static electrical charges.

## Thermal Characteristics

Characteristic	Symbol	Test Conditions*	Value	Units
Package Thermal Resistance	$R_{\theta JA}$	4-layer PCB based on JEDEC standard	38	°C/W

\*Additional thermal information available on Allegro website.

## Pin-out Diagram

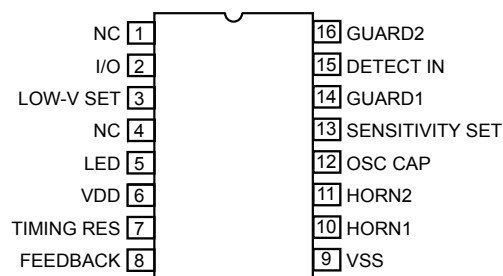

## Terminal List Table

Number	Name	Function
1	NC	No connection
2	I/O	Input/output to interconnected detectors
3	LOW-V SET	Optionally used with a resistor to adjust low-battery threshold
4	NC	No connection
5	LED	Output to drive visible LED
6	VDD	Positive supply voltage
7	TIMING RES	Terminal for timing resistor, sets internal bias (affects timing)
8	FEEDBACK	Input for driving piezoelectric horn
9	VSS	Negative supply voltage
10	HORN1	Output for driving piezoelectric horn
11	HORN2	Complementary output for driving piezoelectric horn
12	OSC CAP	Terminal for charging/discharging an external capacitor to run the oscillator
13	SENSITIVITY SET	Used with a resistor divider to externally set sensitivity for a specific chamber
14	GUARD1	Active guard 1 for detector input
15	DETECT IN	Input from detector chamber
16	GUARD2	Active guard 2 for detector input

**Functional Block Diagram**

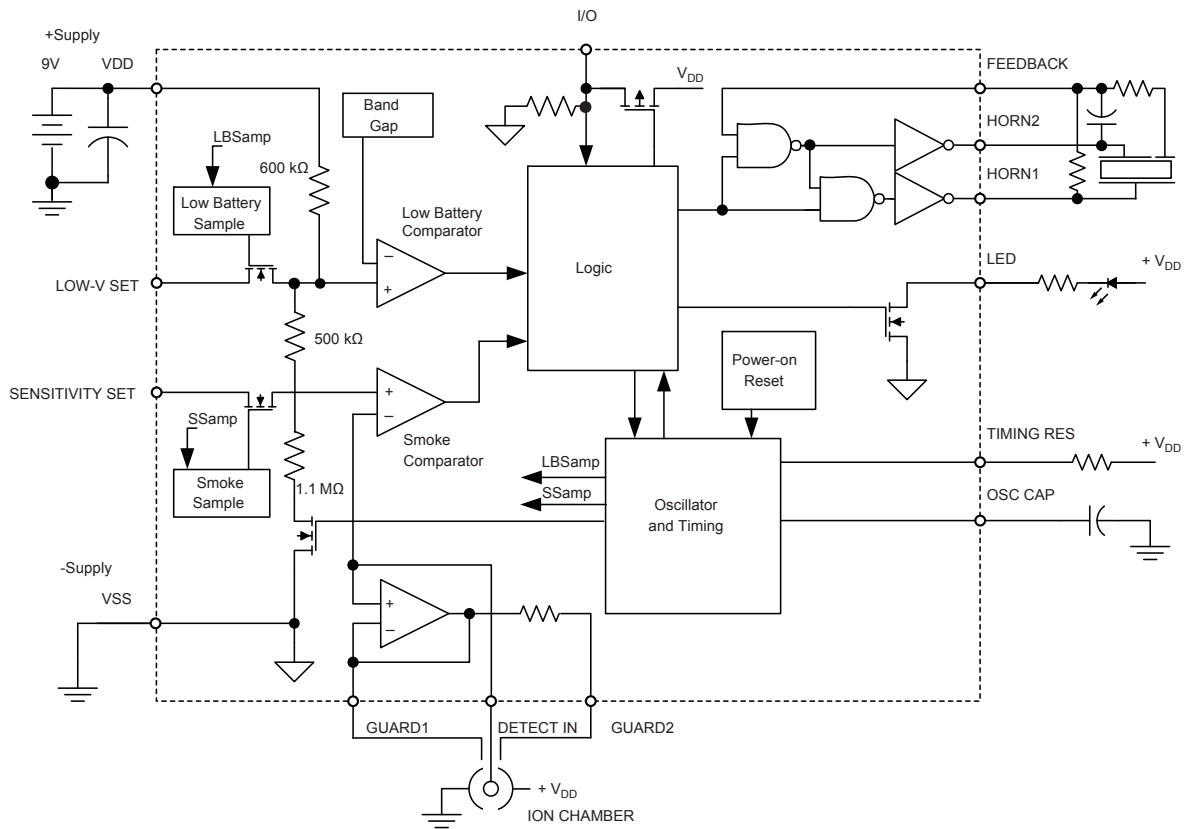

**ELECTRICAL CHARACTERISTICS**<sup>1,2</sup> at  $T_A = 25^\circ\text{C}$ ,  $V_{DD} = 9.0\text{ V}$ ,  $V_{SS} = 0\text{ V}$ ,  $C_{OSSCAP} = 0.1\ \mu\text{F}$ ,  
 $R_{TIMINGRES} = 8.2\ \text{M}\Omega$  (unless otherwise noted)

Characteristic	Symbol	Test Conditions	Test Pin	Min.	Typ.	Max.	Units
Supply Voltage Range	$V_{DD}$	Operating	6	6.0	9.0	12	V
Supply Current	$I_{DD}$	$V_{DD} = 9.0\text{ V}$ , no alarm, no loads	6	—	5.0	9.0	$\mu\text{A}$
		$V_{DD} = 12\text{ V}$ , no alarm, no loads	6	—	—	12	$\mu\text{A}$
Detector Input Current	$I_{DETECTIN}$	0% to 40% RH, $V_{IN} = 0$ to $9.0\text{ V}$	15	—	—	$\pm 1.0$	$\text{pA}$
Input Offset Voltage	$V_{OS(GUARD1)}$	Active GUARD1	14, 15	—	—	$\pm 100$	mV
	$V_{OS(GUARD2)}$	Active GUARD2	16, 15	—	—	$\pm 100$	mV
	$V_{OS}$	Detect comparator	15, 13	—	—	$\pm 50$	mV
Common Mode Range	$V_{CM(\text{guard})}$	Guard amplifier	14, 15	2.0	—	$V_{DD} - 0.5$	V
	$V_{CM}$	Smoke comparator	13, 15	0.5	—	$V_{DD} - 2.0$	V
Active Guard Impedance	$Z_{AG1}$	GUARD1 to VSS	14	—	10	—	$\text{k}\Omega$
	$Z_{AG2}$	GUARD2 to VSS	16	—	500	—	$\text{k}\Omega$
Oscillator Period	$t_{osc}$	No alarm	12	1.34	1.67	2.00	s
	$t_{osc(\text{alarm})}$	Local or remote alarm	12	37.50	41.67	45.84	ms
Oscillator Pulse Width	$t_{w(\text{osc})}$		12	8.0	10	12	ms
Low-Battery Threshold	$V_{DD(\text{th})}$	$T_A = 0^\circ\text{C}$ to $50^\circ\text{C}$ , LOW-V SET open circuit	6	7.2	—	7.8	V
Horn Output Voltage	$V_{OL}$	$I_{OUT} = 16\text{ mA}$ , $V_{DD} = 9.0\text{ V}$	10, 11	—	0.1	0.5	V
		$I_{OUT} = 16\text{ mA}$ , $V_{DD} = 7.2\text{ V}$	10, 11	—	—	0.9	V
	$V_{OH}$	$I_{OUT} = -16\text{ mA}$ , $V_{DD} = 9.0\text{ V}$	10, 11	8.5	8.8	—	V
		$I_{OUT} = -16\text{ mA}$ , $V_{DD} = 7.2\text{ V}$	10, 11	6.3	—	—	V
Horn Output On-Time	$t_{on(\text{horn})}$	Local or remote alarm	10, 11	120	160	208	ms
	$t_{w(\text{horn})}$	Low battery	10, 11	8.0	10	12	ms
Horn Output Off-Time	$t_{off(\text{horn})}$	Local or remote alarm	10, 11	60	80	104	ms
	$t_{horn}$	Low battery	10, 11	32	40	48	s
LED Output-On Current	$I_{LED}$	$V_{DD} = 7.2\text{ V}$ , $V_{LED} = 1.0\text{ V}$	5	10	—	—	$\text{mA}$
LED Output On-Time	$t_{w(LED)}$		5	8.0	10	12	ms
LED Output Off-Time	$t_{LED1}$	No alarm, in standby	5	32	40	48	s
	$t_{LED3}$	Local alarm or test alarm	5	0.76	0.97	1.14	s
	$t_{LED4}$	Remote alarm, no local smoke	5	—	No LED pulses	—	s

Continued on the next page...

**ELECTRICAL CHARACTERISTICS**<sup>1,2</sup> (continued) at  $T_A = 25^\circ\text{C}$ ,  $V_{DD} = 9.0\text{ V}$ ,  $V_{SS} = 0\text{ V}$ ,  $C_{OSCCAP} = 0.1\ \mu\text{F}$ ,  $R_{TIMINGRES} = 8.2\ \text{M}\Omega$  (unless otherwise noted)

Characteristic	Symbol	Test Conditions	Test Pin	Min.	Typ.	Max.	Units
I/O Current	$I_{IOL}$	No alarm, $V_{I/O} = V_{DD} - 2.0\text{ V}$	2	25	—	60	$\mu\text{A}$
	$I_{IOH}$	Local alarm, $V_{I/O} = V_{DD} - 2.0\text{ V}$	2	-7.5	—	—	mA
I/O Alarm Voltage	$V_{IH(I/O)}$	External "alarm" in	2	3.0	—	—	V
I/O Delay	$t_{r(I/O)}$	Local or test alarm to I/O active	2	—	3.0	—	s

<sup>1</sup>Negative current is defined as coming out of the specified device pin (sourcing).

<sup>2</sup>Alarm (smoke) condition is defined as  $V_{DETECTIN} > V_{SENSITIVITYSET}$ ; no alarm (no smoke) condition is defined as  $V_{DETECTIN} < V_{SENSITIVITYSET}$ .

## Circuit Description

The A5350 is a low-current, BiCMOS circuit providing all of the required features for an ionization-type smoke detector. The alarm polarity on DETECT IN is inverted as compared with typical ion-type devices. The DETECT IN voltage must rise above the SENSITIVITY SET voltage in order to cause an alarm.

### Oscillator

An internal oscillator operates with a period of 1.67 seconds during no-smoke conditions. Every 1.67 seconds, internal power is applied to the entire circuit for 10 ms and a check is made for smoke. Every 24 clock cycles (approximately 40 seconds), the LED pin is pulsed and a check is made for low battery by comparing  $V_{DD}$  to an internal reference. Because very-low currents are used in the device, the oscillator capacitor at the OSC CAP pin should be a low-leakage type (PTFE, polystyrene, or polypropylene).

### Detector Circuitry

When the voltage on the DETECT IN pin is greater than the voltage on the SENSITIVITY SET pin, the A5350 evaluates this as a *smoke condition*.

An active guard is provided on GUARD1 and GUARD2, the two pins adjacent to the detector input, the DETECT IN pin.  $V_{GUARD1}$  and  $V_{GUARD2}$  will be within 100 mV of  $V_{DETECTIN}$ . This will keep surface leakage currents to a minimum and provide a method of measuring the input voltage without loading the ionization chamber. The active guard amplifier is not power strobed and thus provides constant protection from surface leakage currents. The detector input has internal diode protection against electrostatic damage.

### Alarm Circuitry

If smoke is detected, the oscillator period changes to 40 ms and the horn is enabled. The horn output is typically 160 ms on, 80 ms off. During the off-time, smoke is checked and further alarm output will be inhibited if smoke is not sensed. During a smoke condition, the low-battery alarm is inhibited and the LED is pulsed approximately once every second.

### Sensitivity Adjust

The detector sensitivity must be externally set to the individual characteristics of the ionization chamber by connecting the

SENSITIVITY SET pin to a resistor divider connected between the VDD and VSS pins.

### Low Battery

The low battery condition threshold is set internally by a voltage divider connected between VDD and VSS. The threshold can be externally adjusted by connecting a resistor between the LOW-V SET pin and either the VDD or VSS pins.

To increase the threshold, a resistor can be connected between LOW-V SET and VSS. Given an initial threshold,  $V_{(th)init}$  (nominally 7.5 V), and a target threshold,  $V_{(th)set}$ , the resistor should have the value:

$$R_{LOWVSET} = 600E3 \times K / (1 - 0.375 \times K) ,$$

where

$$K = 1 / (V_{(th)set} / [0.727 \times V_{(th)init}] - 1) .$$

To decrease the threshold, a resistor can be connected between LOW-V SET and VDD. Given an initial threshold,  $V_{(th)init}$  (nominally 7.5 V), and a target threshold,  $V_{(th)set}$ , the resistor should have the value:

$$R_{LOWVSET} = 960E3 \times K / (0.6 - 1.6 \times K) ,$$

where

$$K = V_{(th)set} / (0.727 \times V_{(th)init}) - 1 .$$

The battery voltage level is checked approximately every 40 seconds during the (approximately) 10 mA, 10 ms LED pulse. If an LED is not used, it should be replaced with an equivalent resistor

(typically 500 to 1000  $\Omega$ ) such that the battery loading remains about 10 mA.

### I/O

A connection to the I/O pin allows multiple smoke detectors to be interconnected. If any single unit detects smoke, its I/O pin is driven high (after a nominal 3 s delay), and all connected units will sound their associated horns. When the I/O pin is driven high by another device, the oscillator immediately speeds up to its 41.7 ms period. The remainder of the sped-up clock cycle, and two additional consecutive clock cycles with I/O high are required to cause an alarm. If the I/O pin falls below its threshold at any time during those (approximately) 83.4 ms, an internal latch is reset and there will not be an alarm. Thus, the I/O must remain high for (approximately) 93.9 ms in order to cause an alarm. This filtering provides significant immunity to I/O noise.

The LED is suppressed when an alarm is signaled from an interconnected unit, and any local alarm condition causes the I/O pin to be ignored as an input. This pin has an on-chip pulldown device and must be left unconnected if not used.

### Testing

On power-up, all internal counters are reset. Internal test circuitry allows low battery check by holding the FEEDBACK and OSC CAP pins low during power-up, then reducing  $V_{DD}$  and monitoring the HORN1 pin. HORN1 will be driven high when  $V_{DD}$  falls below the low-battery threshold. All functional tests can be accelerated by driving the OSC CAP pin with a 2 kHz square wave. The 10 ms strobe period must be maintained for proper operation of the comparator circuitry.



**Timing Diagrams**  
(Not to scale)

▮ Test event

**Standby Mode**

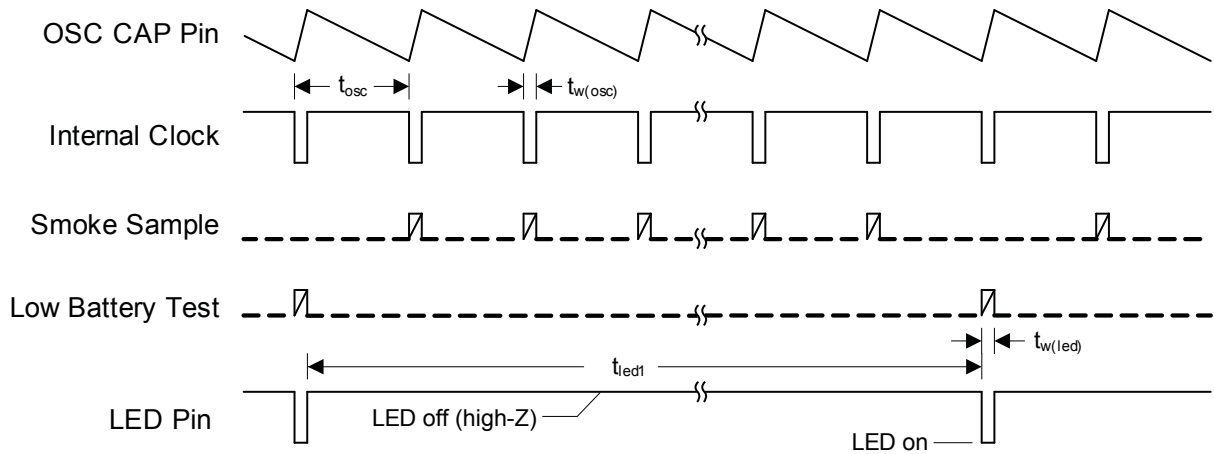

**Low Battery Condition**

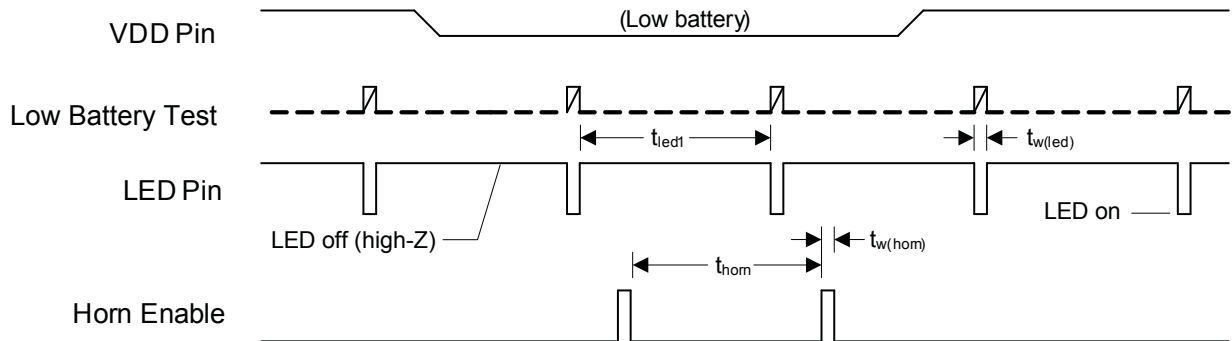

**Local Smoke Detection/Test Alarm Condition**

∇ Test event

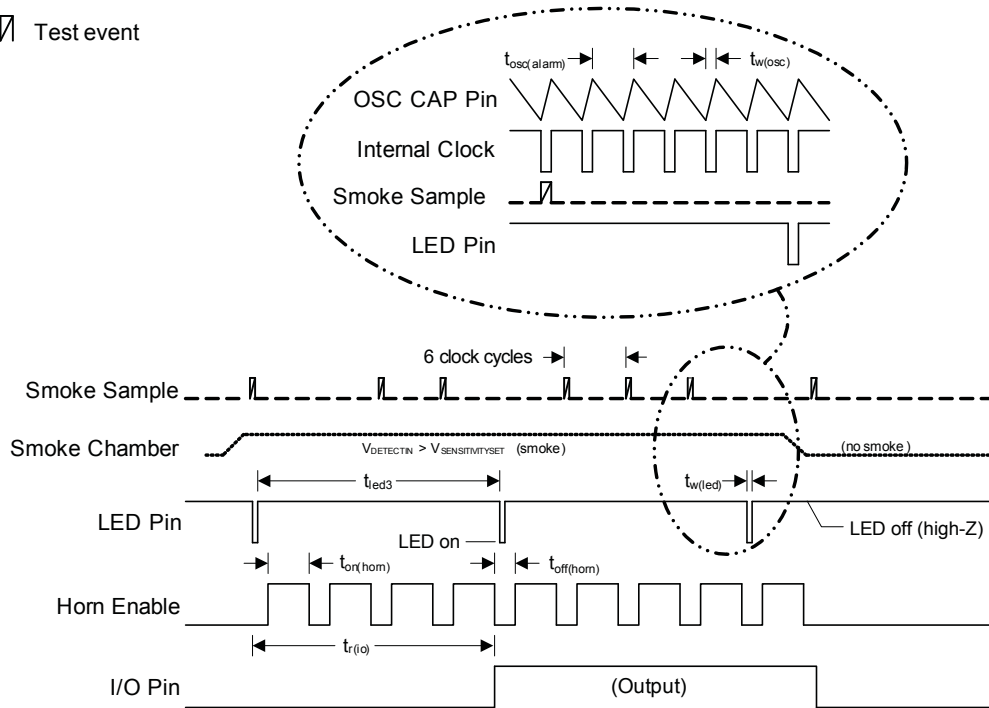

**Remote Alarm Condition**

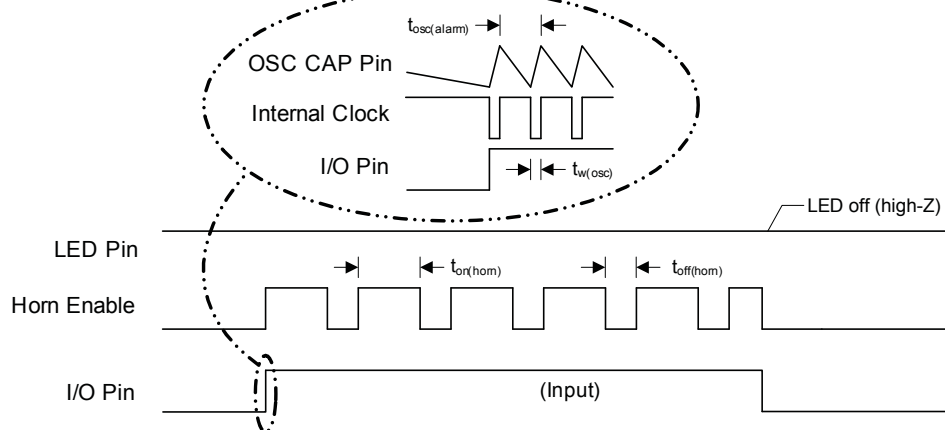

## Package A, 16-Pin DIP

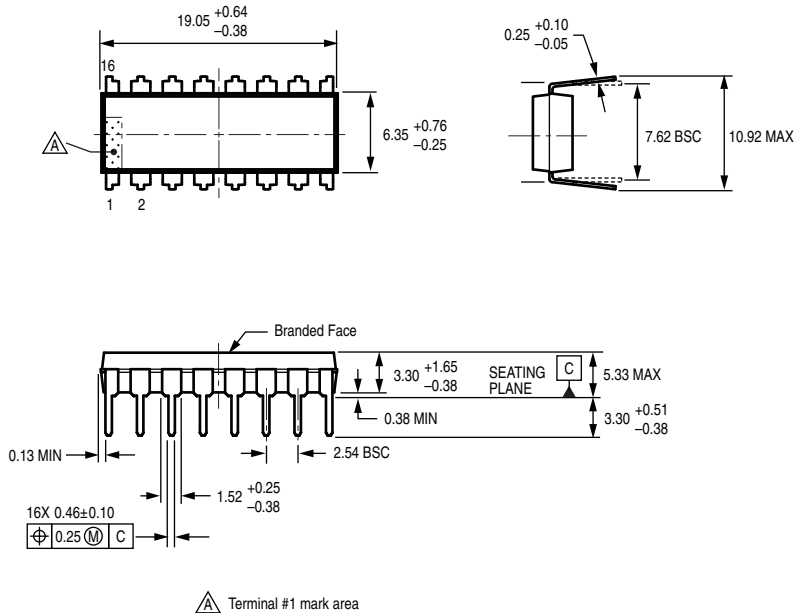

For Reference Only; not for tooling use (reference MS-001BB)  
 Dimensions in millimeters  
 Dimensions exclusive of mold flash, gate burrs, and dambar protrusions  
 Exact case and lead configuration at supplier discretion within limits shown

Allegro MicroSystems offers an industry-leading range of ionization and photoelectric smoke detector ICs. For a current listing, please visit our website at:

[www.allegromicro.com](http://www.allegromicro.com)

Copyright ©1995-2009, Allegro MicroSystems, Inc.

The products described here are manufactured under one or more U.S. patents or U.S. patents pending.

Allegro MicroSystems, Inc. reserves the right to make, from time to time, such departures from the detail specifications as may be required to permit improvements in the performance, reliability, or manufacturability of its products. Before placing an order, the user is cautioned to verify that the information being relied upon is current.

Allegro's products are not to be used in life support devices or systems, if a failure of an Allegro product can reasonably be expected to cause the failure of that life support device or system, or to affect the safety or effectiveness of that device or system.

The information included herein is believed to be accurate and reliable. However, Allegro MicroSystems, Inc. assumes no responsibility for its use; nor for any infringement of patents or other rights of third parties which may result from its use.

For the latest version of this document, visit our website:

[www.allegromicro.com](http://www.allegromicro.com)

